

## experimental exam 2025- model (A)

➤ First: choose the correct answer:

1. The role of coke in a blast furnace is similar to that of natural gas in a Midrex furnace. Which of the following explains this statement?
  - a) Both of them are used as catalysts to reduce time consumed in reduction process.
  - b) Both of them are used to prepare the reducing agent.
  - c) Both of them are used as a reducing agent.
  - d) Both of them are used as fuel to operate the furnaces at high temperatures.
  
2. Calculate the degree of dissociation for a weak monoprotic acid with concentration 0.01 M and pH = 5.
  - a) 0.05
  - b) 0.001
  - c) 0.01
  - d) 0.005
  
3. If 3 Faradays are required to deposit 1 mole of metal ( $X^{+x}$ ). What is the chemical formula of metal oxide?
  - a)  $XO_2$
  - b)  $XO$
  - c)  $X_2O_3$
  - d) No suitable answer



4. Dilute hydrochloric acid added to a solution containing equal concentrations of  $\text{Fe}^{2+}$ ,  $\text{Ca}^{2+}$ ,  $\text{Pb}^{2+}$  and  $\text{Cu}^{2+}$ . Which one of these cations would precipitate.

- a)  $\text{Cu}^{2+}$
- b)  $\text{Fe}^{2+}$
- c)  $\text{Pb}^{2+}$
- d)  $\text{Ca}^{2+}$

5. Which of the following considered a tertiary monohydric alcohol.

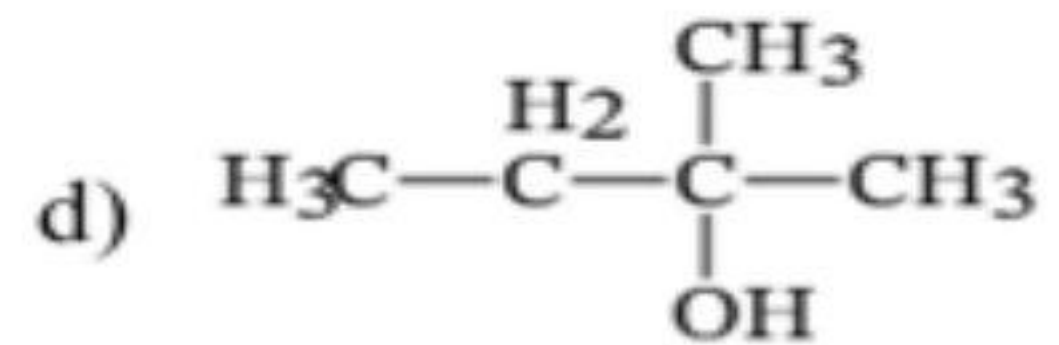
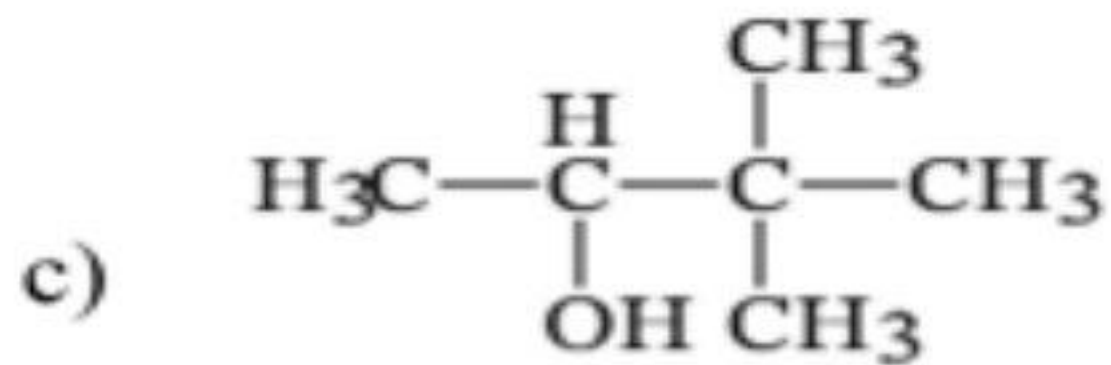
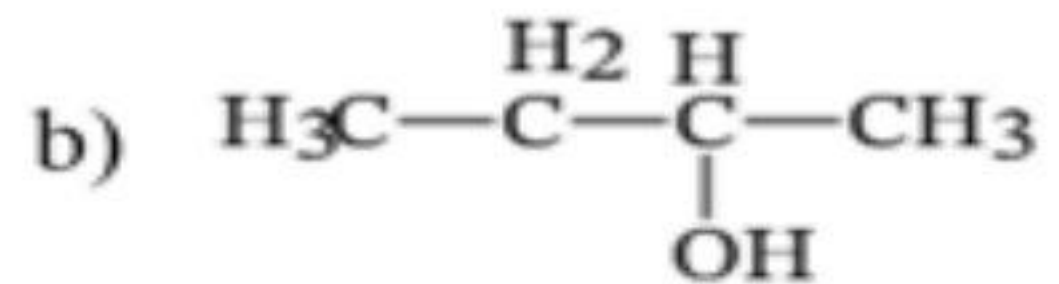
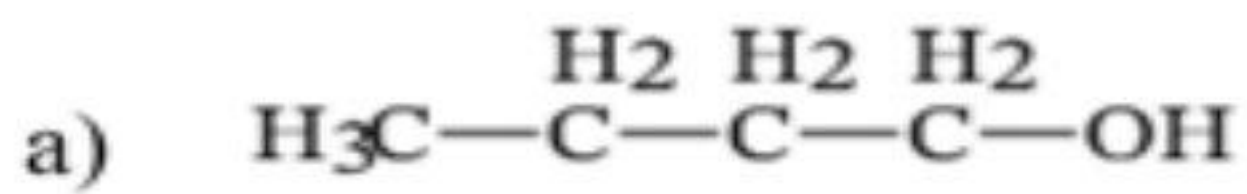

6. Which of the following happens upon closing the Galvanic cell circuit.

- a) Anions move towards the anode through the porous septum.
- b) Cations move toward the anode through the porous septum
- c) Electrons move through the external wire from the +ve rode towards the -ve rod.
- d) Electrons move through the external wire from the cathode toward the anode.



7. What is the product of thermal cracking for the following compound:

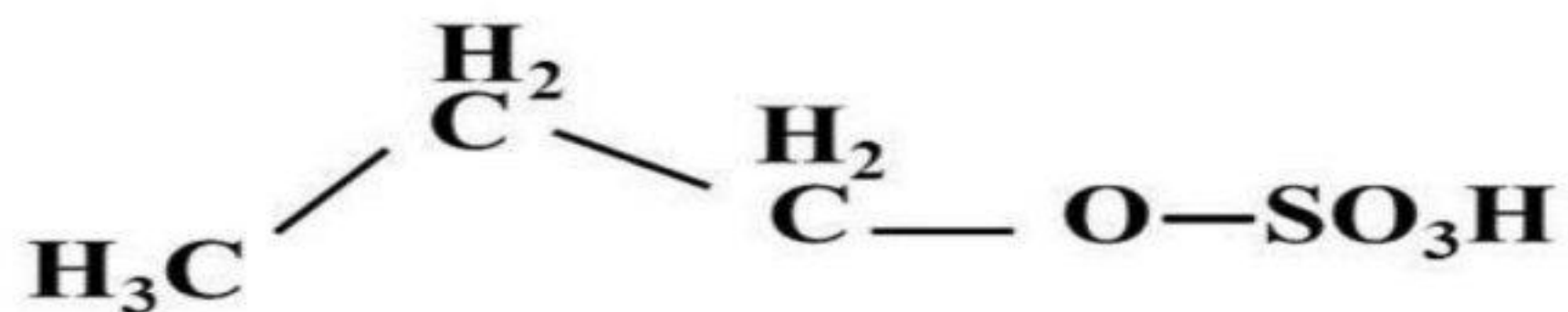

- a)  $\text{C}_2\text{H}_4$
- b)  $\text{C}_3\text{H}_8$
- c)  $\text{C}_3\text{H}_7$
- d)  $\text{C}_3\text{H}_6$

8. Study the following table:

Acid	HU	HW	HY	HX
Ionization degree	2.8%	5.9%	13.4%	9.2%

Which acid has the highest conductivity.....

- a) HU
  - b) HW
  - c) HY
  - d) HX
9. Which analytical group can be precipitated by acidic Hydrogen sulphide.
- a) The third analytical group
  - b) The second analytical group
  - c) The fifth analytical group
  - d) The first analytical group

10. What is the IUPAC name of the following formula of a halogenated alkane.....

- a) 3,3-Bromo-1-Chloropropane
- b) 1,1-Dibromo-3-chloropropane
- c) 1,1-Bromo-3-chloropropane
- d) 3,3-Dibromo-1-chloropropane

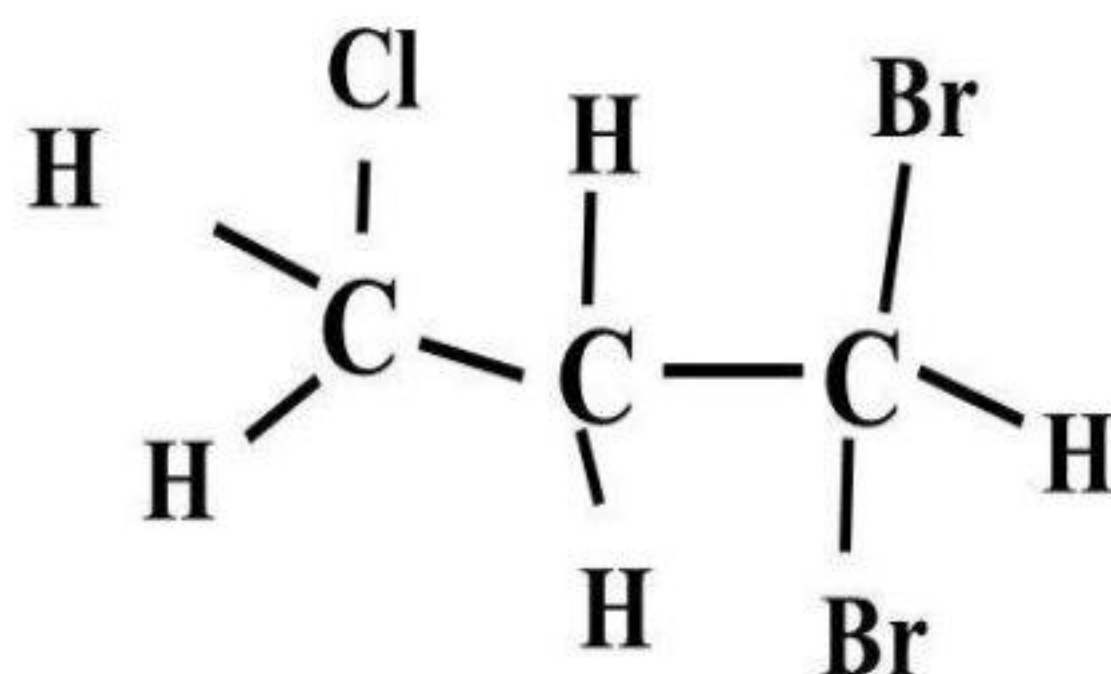

11. Study the following diagram, then find out A, B and C



- a) A: Fe , B: FeSO<sub>4</sub> , C: Fe<sub>2</sub>O<sub>3</sub>
- b) A: Fe , B: Fe<sub>2</sub>(SO<sub>4</sub>)<sub>3</sub> , C: Fe<sub>2</sub>O<sub>3</sub>
- c) A: FeCl<sub>3</sub> , B: FeSO<sub>4</sub> , C: Fe<sub>2</sub>O<sub>3</sub>
- d) A: Fe<sub>2</sub>O<sub>3</sub> , B: FeSO<sub>4</sub> , C: Fe

12. Dilute hydrochloric acid could be used to distinguish between .....

- a) Na<sub>2</sub>CO<sub>3</sub> and NaHCO<sub>3</sub>
- b) Na<sub>2</sub>SO<sub>4</sub> and NaCl
- c) Na<sub>2</sub>SO<sub>3</sub> and NaCl
- d) Na<sub>3</sub>PO<sub>4</sub> and NaI

13. During the reversible reaction. Which of the following represents the graph relating concentration and time?

- a) The concentration of reactant decreases until it completely consumed.
- b) The concentration of product increases and concentration of reactant decreases until they reach a constant concentration.
- c) The concentration of both reactants & product increase until they reach equilibrium.
- d) There is no change in the concentration of both reactants & products since the beginning of the reaction.

14. How many hours for a current of 5 ampere strength is needed to precipitate 6.35 g of copper from copper sulphate solution, the cathode reaction is:

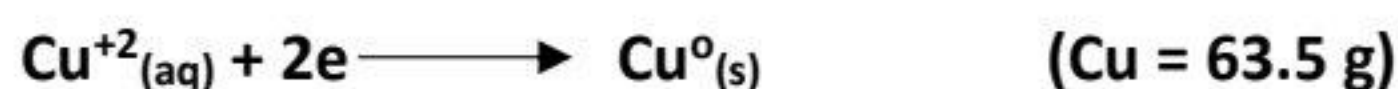

- a) 0.5 h
- b) 1.07 h
- c) 1.5 h
- d) 2.3 h

15. The standard electrode potential,  $E$ , is measured under standard conditions. Which of the following is not a standard condition when measuring these values.

- a) Temperature of 298 K (25 C)
- b) Concentration of solution is 1M
- c)  $\text{KNO}_3$  solution in the salt bridge
- d) Measuring against standard hydrogen electrode

16. These are four cyclic aliphatic hydrocarbons:

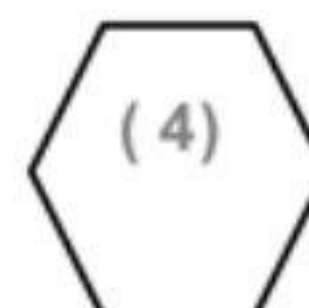
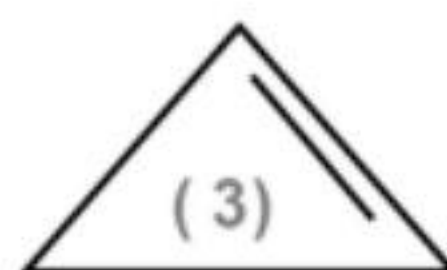
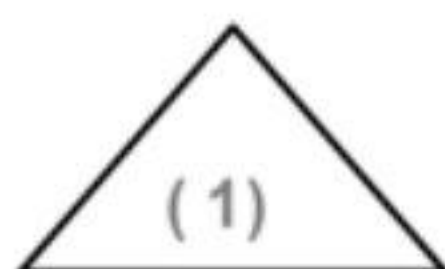

The correct arrange of stability of these compounds: (From less stable to more stable)

- a) (2), (1), (3), (4)
- b) (3), (1), (4), (2)
- c) (1), (3), (2), (4)
- d) (3), (1), (2), (4)

17. Calculate the solubility product ( $K_{sp}$ ) of  $\text{Al}(\text{OH})_3$  giving that its degree of solubility equals  $10^{-6}$  mole/liter.

- a)  $2.7 \times 10^{-23}$
- b)  $5.9 \times 10^{-11}$
- c)  $13.5 \times 10^{-10}$
- d)  $8.5 \times 10^{-8}$

18. Which of the following has the largest number of paired electrons.

- a)  ${}_{29}\text{Cu}^{2+}$
- b)  ${}_{23}\text{V}^{5+}$
- c)  ${}_{29}\text{Cu}^{1+}$
- d)  ${}_{24}\text{Cr}^{2+}$

19. Dry distillation of sodium propanoate forms .....

- a)  $\text{C}_3\text{H}_8$
- b)  $\text{C}_2\text{H}_6$
- c)  $\text{C}_4\text{H}_{10}$
- d)  $\text{C}_3\text{H}_6$

20. Consider the following observation of the qualitative analysis of two samples, A and B, of unknown sodium salts.

Test	Sample A	Sample B
Addition of dilute $\text{HCl}(aq)$ to salt solid	No gas evolved	No gas evolved
Addition of concentrated $\text{H}_2\text{SO}_4(aq)$ to salt solid	No gas evolved	No gas evolved
Addition of $\text{BaCl}_2(aq)$ to salt solution	White precipitate insoluble in dilute $\text{HCl}$	White precipitate soluble in dilute $\text{HCl}$

It can be concluded that sample (A) is ..... and sample (B) is .....

- a)  $\text{Na}_2\text{S}$  and  $\text{Na}_2\text{SO}_3$
- b)  $\text{Na}_3\text{PO}_4$  and  $\text{Na}_2\text{SO}_4$
- c)  $\text{Na}_2\text{SO}_4$  and  $\text{Na}_3\text{PO}_4$
- d)  $\text{Na}_2\text{S}_2\text{O}_3$  and  $\text{Na}_2\text{SO}_3$

21. Organic compound obtained from dropping water on calcium carbide then catalytic hydration of the produced gas:

- a) Ethanol
- b) Ethanal
- c) Acetaldehyde
- d) Both (b), (c)

22. Steel, is a solid mixture consisting of carbon atoms get into the holes of an iron atom structure, is an example of

- a) An intermetallic alloy
- b) Brass alloy
- c) A substitutional alloy
- d) An interstitial alloy

23. Which of the following is correct about the solution obtained by mixing 10 ml of 0.2 M KOH with 20 ml of  $\text{H}_3\text{PO}_4$  0.1 molar,

- a) The obtained solution will be acidic and turns methyl orange yellow.
- b) The obtained solution will be alkaline and turns methyl orange yellow.
- c) The concentration of the obtained solution will be 4 M.
- d) The obtained solution will be acidic and turns bromothymol blue yellow.

24. Considered the following equilibrium system



The aqueous bromine is characterized by a yellowish-brown colour but the  $\text{Br}^{-}$  and  $\text{OBr}^{-}$  are colourless. Thus it is expected that the colour of bromine will be fade upon the addition of

.....

- a)  $\text{H}_2\text{SO}_4$
- b)  $\text{KOH}$
- c)  $\text{AgNO}_3$
- d)  $\text{KBr}$

25. Which indicator is not used to differentiate between distilled water and acetic acid solution.

- Litmus
- Phenol phethalein
- Methyl orange
- Bromothymol blue

26. In the opposite diagram:

- Cell (1) contains molten sodium chloride.
- Cell (2) contains aqueous solution of sodium chloride

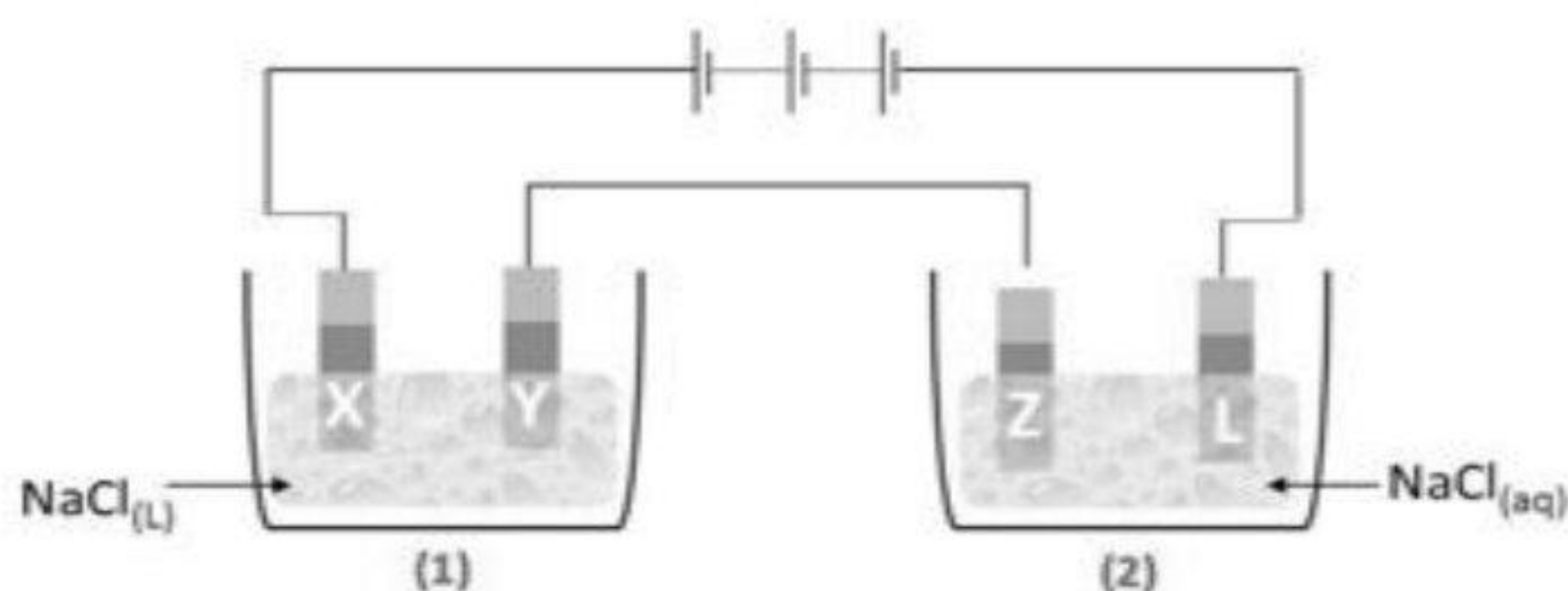

An electrolysis process is made for both of them, the substances formed at the electrodes (X, Y, Z and L) are .....

	X	Y	Z	L
a	Cl <sub>2</sub>	Na	Cl <sub>2</sub>	H <sub>2</sub>
b	H <sub>2</sub>	Cl <sub>2</sub>	Na	Cl <sub>2</sub>
c	Cl <sub>2</sub>	Na	Na	Cl <sub>2</sub>
d	Cl <sub>2</sub>	Na	Na	O <sub>2</sub>

27. Which of the following occurs upon the addition of 3 moles of bromine dissolved in CCl<sub>4</sub> to one of 2-butene.

- The intensity of red colour of bromine decreased.
- The red colour of bromine water discharged.
- The red colour changed into green.
- The intensity of red colour remains unchanged.

28. Which of the following choices suitable to prepare the following compound:

- a) Chlorination of benzene then Sulphonation
- b) Sulphonation of Chlorobenzene
- c) Chlorination of benzene sulphonic acid
- d) No suitable answer

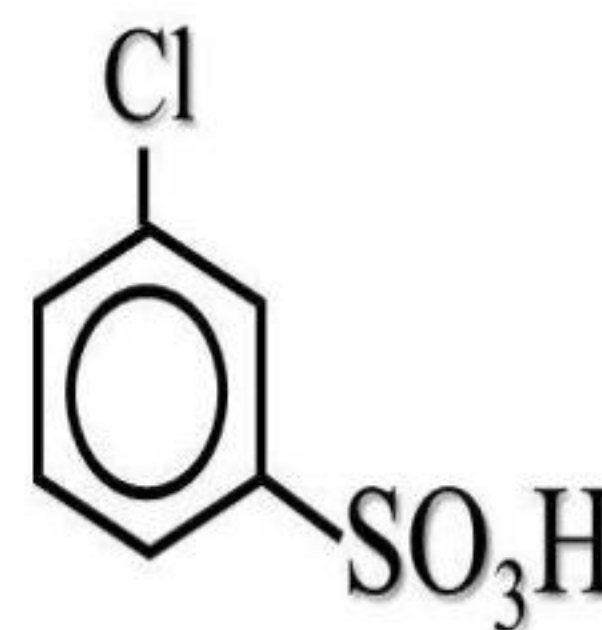

29. Calculate the Pressure of Nitrogen for the following equilibrium:



Given: pressure of Hydrogen and Ammonia are 6.8 and 0.4 atm.

- a) 10 atm
- b) 20 atm
- c) 30 atm
- d) 40 atm

30. Which of the following pairs used to detect Lead acetate .....

- a)  $\text{S}^{2-}$  and  $\text{PO}_4^{3-}$
- b)  $\text{Fe}^{2+}$  and  $\text{SO}_4^{2-}$
- c)  $\text{S}^{2-}$  and  $\text{SO}_4^{2-}$
- d)  $\text{NO}_2^{1-}$  and  $\text{Cl}^{-1}$

31. In which of the following compounds the oxidation number of Iron not changed when heated in air:

- a) Iron II oxalate
- b) Iron II sulphate
- c) Siderite.
- d) Limonite



32. Study the figure below that show the activation energy before and after using Transition element as catalyst, what's the value of activation energy after using catalyst.

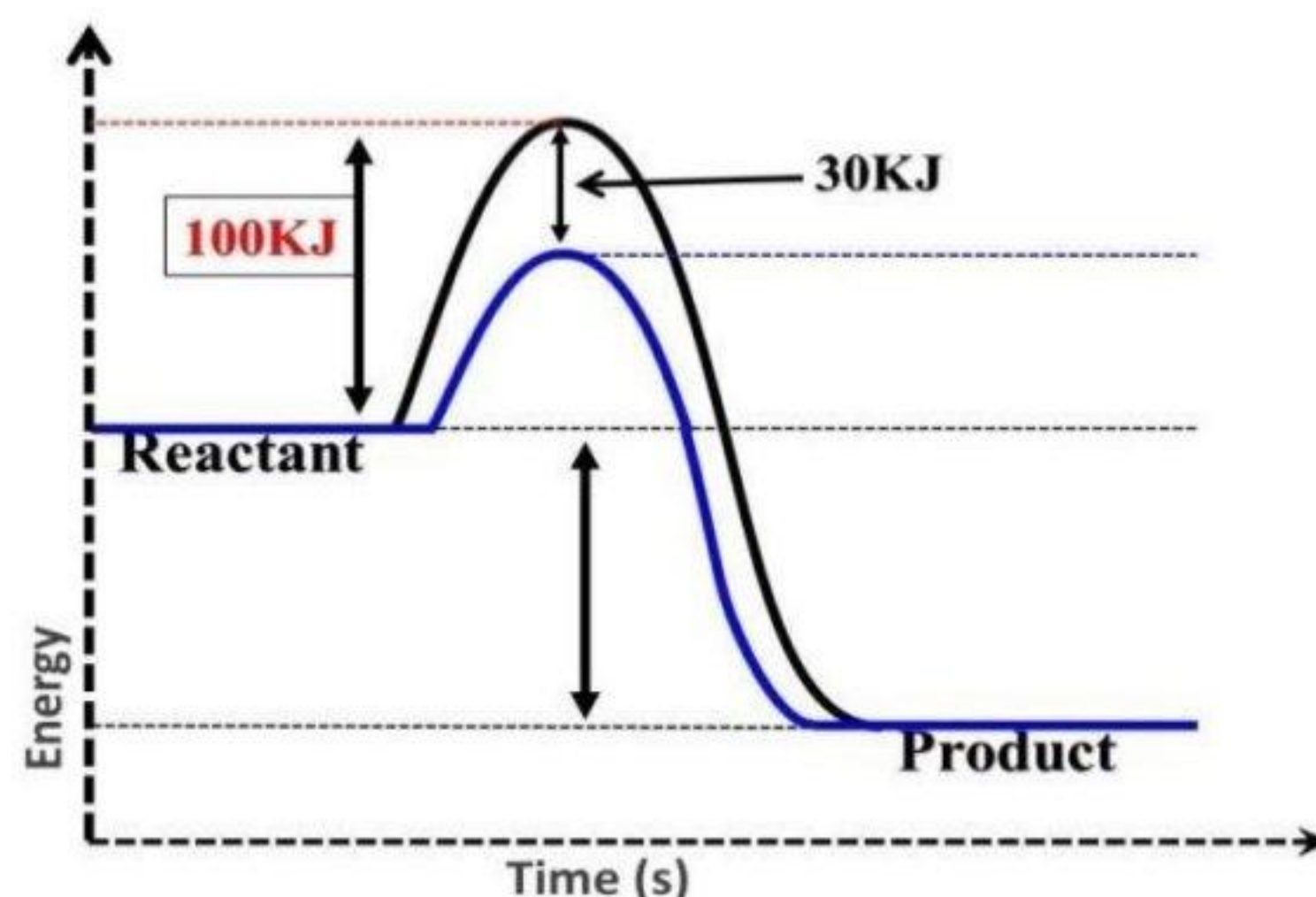

- a) 130 kJ
- b) 30 KJ
- c) 50 kJ
- d) 70 kJ

33. The chemical equilibrium in ..... reactions is a ..... system that takes place when rate of forward equals the rate of backward.

- a) Irreversible, static.
- b) Reversible, static.
- c) Irreversible, dynamic.
- d) Reversible, dynamic.

34. Which one of the following is not a purpose of the salt bridge.

- a) Keep the liquid levels the same.
- b) Neutralizes excess of ions in both half cells.
- c) Keep the solutions separated.
- d) Complete the circuit.

35. A magnesium halide salt has the formula  $MgX_2$ . A 0.415 g sample of  $MgX_2$  was dissolved in 100 ml of pure water, followed by the addition of excess NaOH. The precipitate of  $Mg(OH)_2$  was filtered, washed, and dried. The precipitated was found to have a mass of 0.131 g. what is the identity of X.

[Mg = 24g/mol, O = 16g/mol, H = 1g/mol, F = 19g/mol, Br = 80g/mol, Cl = 35.5g/mol, I =127g/mol]

- a) Al
- b) Br
- c) Cl
- d) F

36. Which of the following compounds used as a cleaner of electronic sets.

- a)  $\text{CHBrClCF}_3$
- b)  $\text{C}_2\text{H}_4$
- c)  $\text{CF}_2\text{Cl}_2$
- d)  $\text{CH}_4$

37. The following produces from the oxidation of an alcohol:



Which of the following alcohols could be the reactant.

A

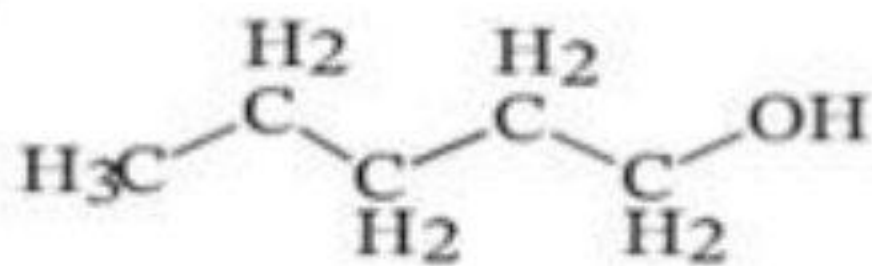

C

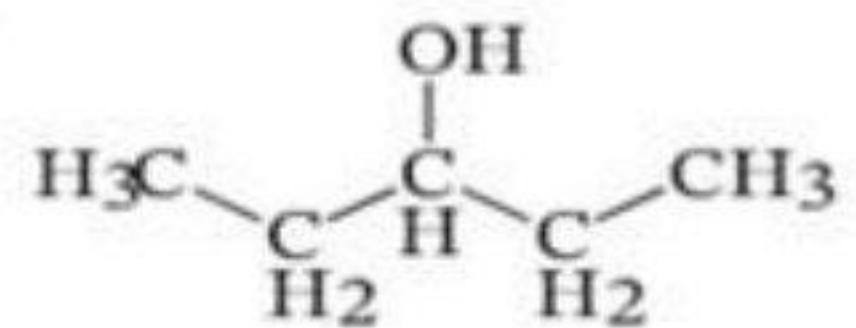

B

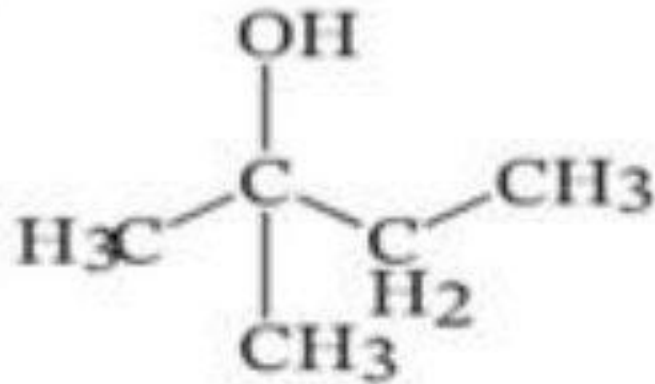

D

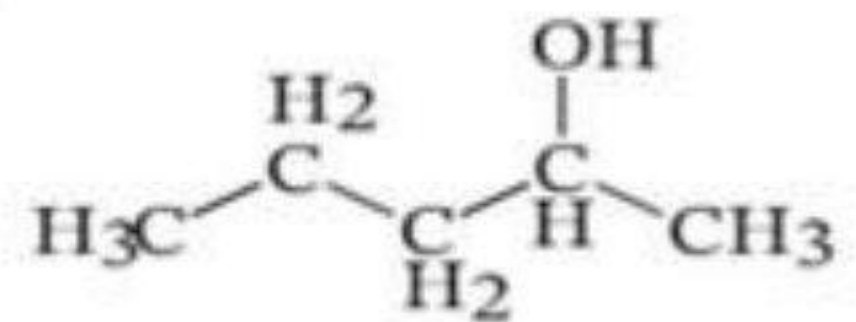

38. The following table represents the standard reduction potential of four elements A,B,C and

D. the galvanic cell produces the highest e.m.f is .....

Element	A	B	C	D
Standard reduction potential (Volt)	- 2.711	-0.28	+1.2	+2.87

- a) (B) as an anode, (D) as a cathode.
- b) (D) as an anode, (A) as a cathode.
- c) (A) as an anode, (D) as a cathode.
- d) (D) as an anode, (C) as a cathode.



لضمان التفوق ابحث دائما عن موقع مدرستك

39. Which of these reactions leads to producing hydrogen gas with faster rate:
- Zinc powder with (2M) HCl.
  - Zinc strip with (2M) HCl.
  - Zinc powder with (1M) HCl.
  - Zinc strip with (1M) HCl.
40. Which of the following statements compare between two d-block elements is correct.
- Titanium is denser than nickel but has a smaller atomic radius.
  - Titanium is less dense than nickel but has a larger atomic radius.
  - Titanium is denser than nickel and has a larger atomic radius.
  - Titanium is less dense than nickel and has a smaller atomic radius.
41. Which of the following is the preferred iron ore for extraction in a blast furnace.
- Siderite
  - Magnetite
  - Limonite
  - Hematite
42. The number of alcoholic isomers of the molecular formula  $C_4H_{10}O$  equals .....
- 2 isomers
  - 3 isomers
  - 4 isomers
  - 5 isomers
43. From the properties of fuel cells .....
- Consumed by time.
  - Supplied with external source of electricity.
  - Store electrical energy as chemical anode and cathode material.
  - Oxygen gas reduced at cathode of fuel cell.

44. Oils and fats could be hydrolyzed using ..... To produce glycerol and .....

- a) NaOH , detergent
- b) HCl , detergent
- c) HCl , soap
- d) NaOH , soap

➤ Second: answer the following essay questions:

45. Arrange the following compounds according to their magnetic moment:

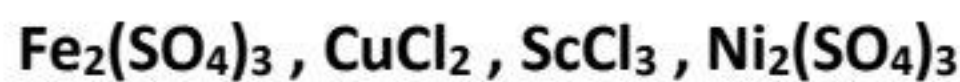

.....

.....

.....

46. Essay: study the following diagram:

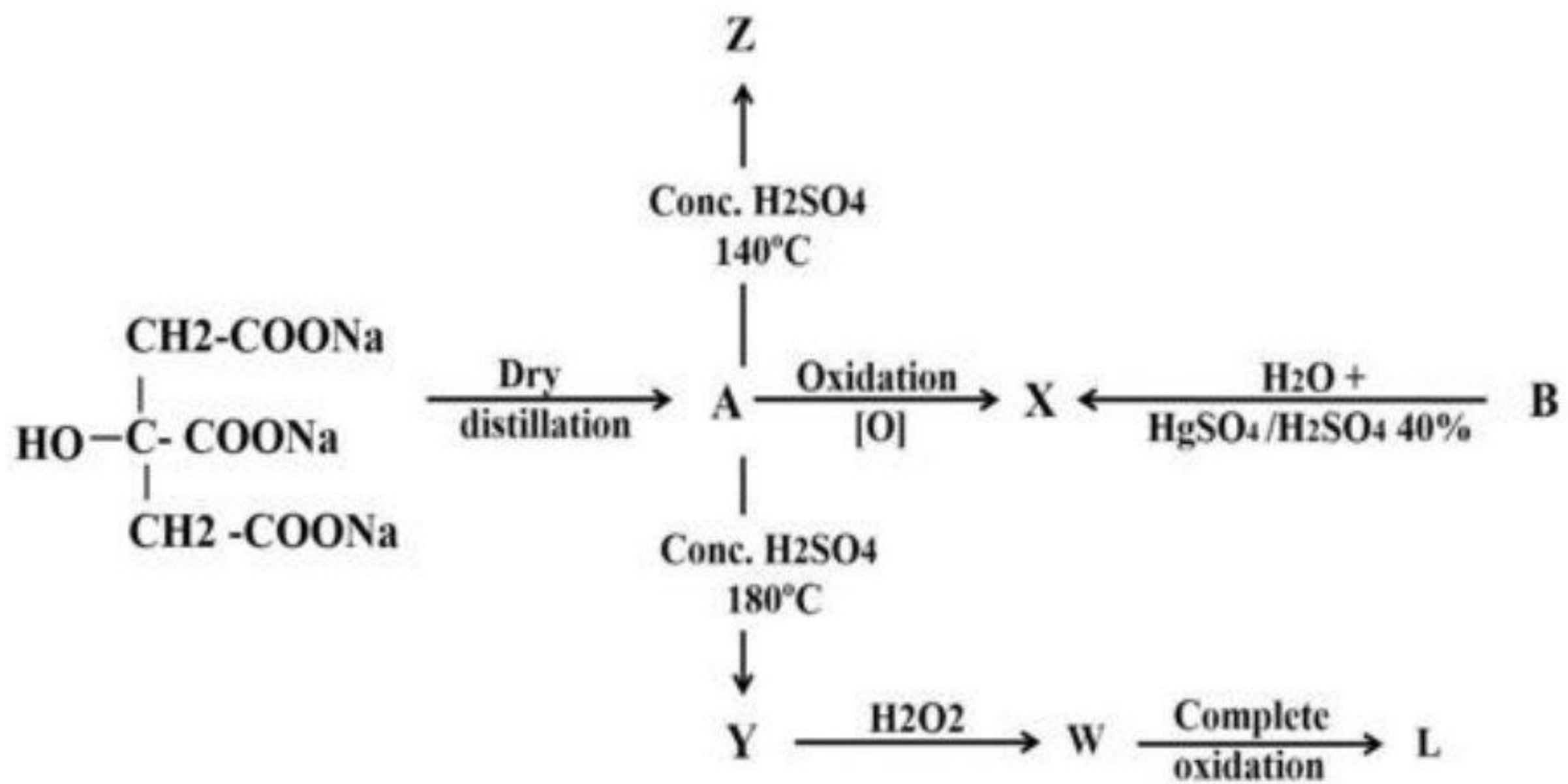

Write the names of: X , B and A

.....

.....

.....

- Arrange A , W , L , Z according to boiling point.

.....

.....

.....

## expermental exam 2025- model (B)

➤ First: choose the correct answer:

1. Which one of the following pairs paramagnetic:
  - a)  $_{30}\text{Zn}^{2+}$  and  $_{26}\text{Fe}^{+2}$
  - b)  $_{21}\text{Sc}^{+3}$  and  $_{26}\text{Fe}^{+2}$
  - c)  $_{30}\text{Zn}^{2+}$  and  $_{24}\text{Cr}^{+2}$
  - d)  $_{26}\text{Fe}^{+2}$  and  $_{24}\text{Cr}^{+2}$
  
2. The number of main transition elements in first and second series are .....
  - a) 20 elements.
  - b) 32 elements.
  - c) 18 elements.
  - d) 16 elements.
  
3. The ions which have the electronic configuration  $[_{18}\text{Ar}], 3d^4$  are .....
  - a)  $_{25}\text{Mn}^{+2}$  and  $_{27}\text{Co}^{+2}$
  - b)  $_{26}\text{Fe}^{+3}$  and  $_{24}\text{Cr}^{+3}$
  - c)  $_{24}\text{Cr}^{+2}$  and  $_{25}\text{Mn}^{+3}$
  - d)  $_{26}\text{Fe}^{+2}$  and  $_{27}\text{Co}^{+3}$
  
4. The atomic radii of d-block elements from chromium to copper are relatively constant, which of the following causes this phenomenon?
  - a) Electrons filling the 3d orbital.
  - b) Increasing nuclear charge.
  - c) Greater repulsion between 3d electrons.
  - d) Answers (b) and (c) are correct.



لضمان التفوق ابحاث دائما عن موقع مدرستك

5. All the following from the properties of titanium except .....
- a) Can form different oxides as  $TiO$ ,  $Ti_2O_3$  and  $TiO_2$ .
  - b) Rigid and strong metal with low density.
  - c) Does not cause any poisoning effect so body when implanted.
  - d) Its melting point lower than aluminum.
6. During Haber-method to prepare ammonia:  $N_{2(g)} + 3H_{2(g)} = 2NH_{3(g)}$ . Which of the following conditions are suitable to increase amount ammonia?
- a) Increasing pressure and adding zinc powder.
  - b) Decreasing pressure and adding iron powder.
  - c) Increasing pressure and adding iron powder.
  - d) Decreasing pressure and adding zinc powder.
7. Which of the following processes does not aim to improve the physical and mechanical properties of iron ore.
- a) Sintering process.
  - b) Roasting process.
  - c) Crushing process.
  - d) Concentrating process.
8. Which of the following alloys its elements are chemically combined .....
- a) Alloys used in heating coils and electric furnaces.
  - b) Alloys used in real way tracks.
  - c) Cementite.
  - d) Bauxite.

9. Oxygen converter is charged with .....
- Hematite.
  - Carbon dioxide.
  - Molten iron.
  - Iron (III) oxide.
10. Reactions of iron with acids depend on .....
- Type of acid and its amount.
  - Amount of acid and its concentration.
  - Type of acid and its concentration.
  - Basicity of acid and its amount.
11. One of iron compounds (X) when heated in air, a solid substance (B) is formed along with two different gases, one of them turbid clear limewater. Which of the following statements best compare between (X) and (B).
- X is diamagnetic substance while B is paramagnetic one.
  - X is paramagnetic substance while B is diamagnetic one.
  - X has magnetic moment more than that of B.
  - X has magnetic moment less than that of B.
12. Which of the following salts when heated becomes insoluble in water .....
- $\text{NaHCO}_3$
  - $(\text{NH}_4)\text{HCO}_3$
  - $\text{Ca}(\text{HCO}_3)_2$
  - $\text{KHCO}_3$

13. Which of the following is the chemical formula for the basic radical whose salt solution forms a white precipitate when dilute sulfuric acid added to it.

- a)  $\text{Cu}^{2+}$
- b)  $\text{Fe}^{2+}$
- c)  $\text{Ca}^{2+}$
- d)  $\text{Al}^{3+}$

14. Which of the following could act as a standard solution for the determination of ammonium hydroxide .....

- a) Ammonium chloride.
- b) Ammonium carbonate.
- c) Hydrochloric acid.
- d) Sodium carbonate.

15. What is the mass of the precipitate produced from the addition of 100 mL of a 0.1 M sodium hydroxide solution to an excess of iron (II) sulphate.

[NaOH = 40 g/mol and  $\text{Fe}(\text{OH})_2$  = 90 g/mol]

- a) 0.005 g
- b) 0.900 g
- c) 0.760 g
- d) 0.450 g

16. Which of the following is correct to detect the sulphite anion?

- a) Adding an equal volume of dilute HCl, followed by heating, which results in production of a gas that turns filter paper soaked in acidified aqueous  $\text{KMnO}_4$  from purple to colourless.
- b) Adding an equal volume of dilute NaOH, followed by heating, which results in production of a gas that turns moist litmus paper blue.
- c) Adding an aqueous ammonia solution, which produces a yellow precipitate.
- d) Adding an equal volume of acetic acid, followed by silver nitrate, which gives a white precipitate.

17. Which of the following used to differentiate between two separated solid salts of barium sulphate and barium phosphate.

- Concentrated sulphuric acid.
- Concentrated ammonia solution.
- Acidified potassium permanganate.
- Dilute HCl.

18. On adding excess amount of sodium hydroxide to three different solutions containing equal amount of  $\text{Fe}^{+2}$ ,  $\text{Fe}^{+3}$  and  $\text{Al}^{+3}$ , respectively. Three different precipitates are formed. Which of the following diagrams expresses the ratio between the mass of the precipitate?

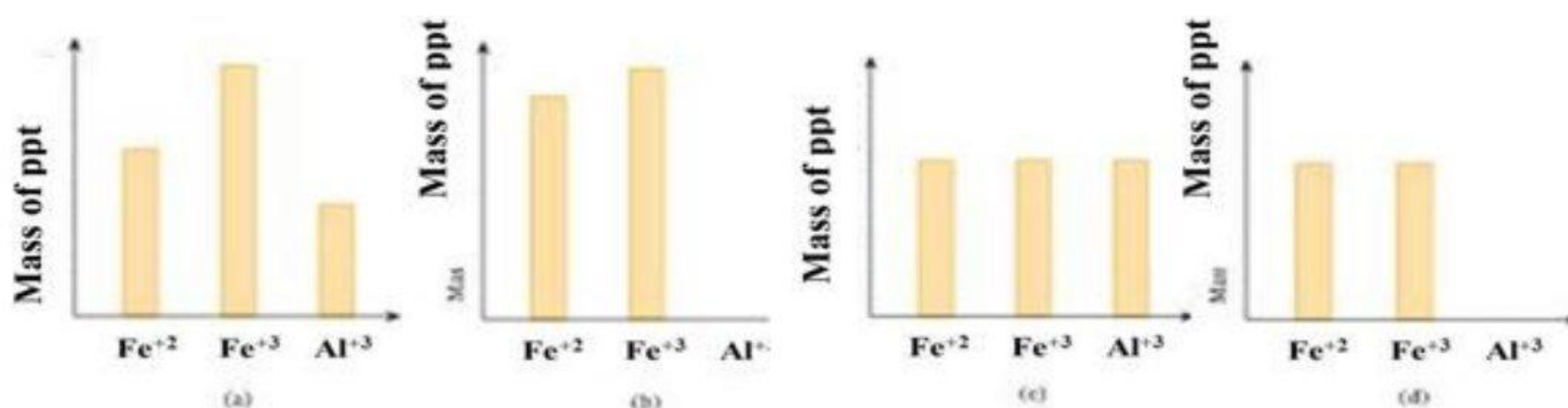

19. Dissolving 18.5 g of calcium hydroxide in 0.5 L nitric acid (2 molar), so the resulting solution will be .....

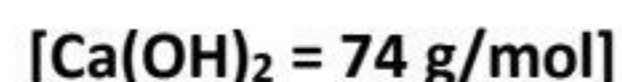

- Neutral.
- Acidic.
- Alkaline.
- Amphoteric.

20. An hydrated metal salt has the chemical formula  $\text{XBr}_2 \cdot 6\text{H}_2\text{O}$ . when a 4.578 g sample of the salt is heated, the sample decreases in mass by 1.515 g. which of the following is the identity of metal X.

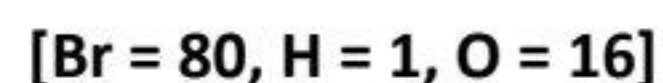

- Mn [M = 55 g/mol]
- V [M = 51 g/mol]
- Cu [M = 63.5 g/mol]
- Co [M = 58.35 g/mol]

21. Calculate the volume of evolved chlorine when passing 19300 coulombs in a solution of copper II chloride between two platinum electrodes.

- a) 11.2 L
- b) 22.4 L
- c) 2.24 L
- d) 1.12 L

22. Consider the figure below: what may cause the electric current to stop flowing.

- a) The full consumption of the  $\text{Cu}^{2+}$  ions.
- b) Removing the salt bridge.
- c) The full consumption of the Cu electrode.
- d) Both (a) and (b) are correct.

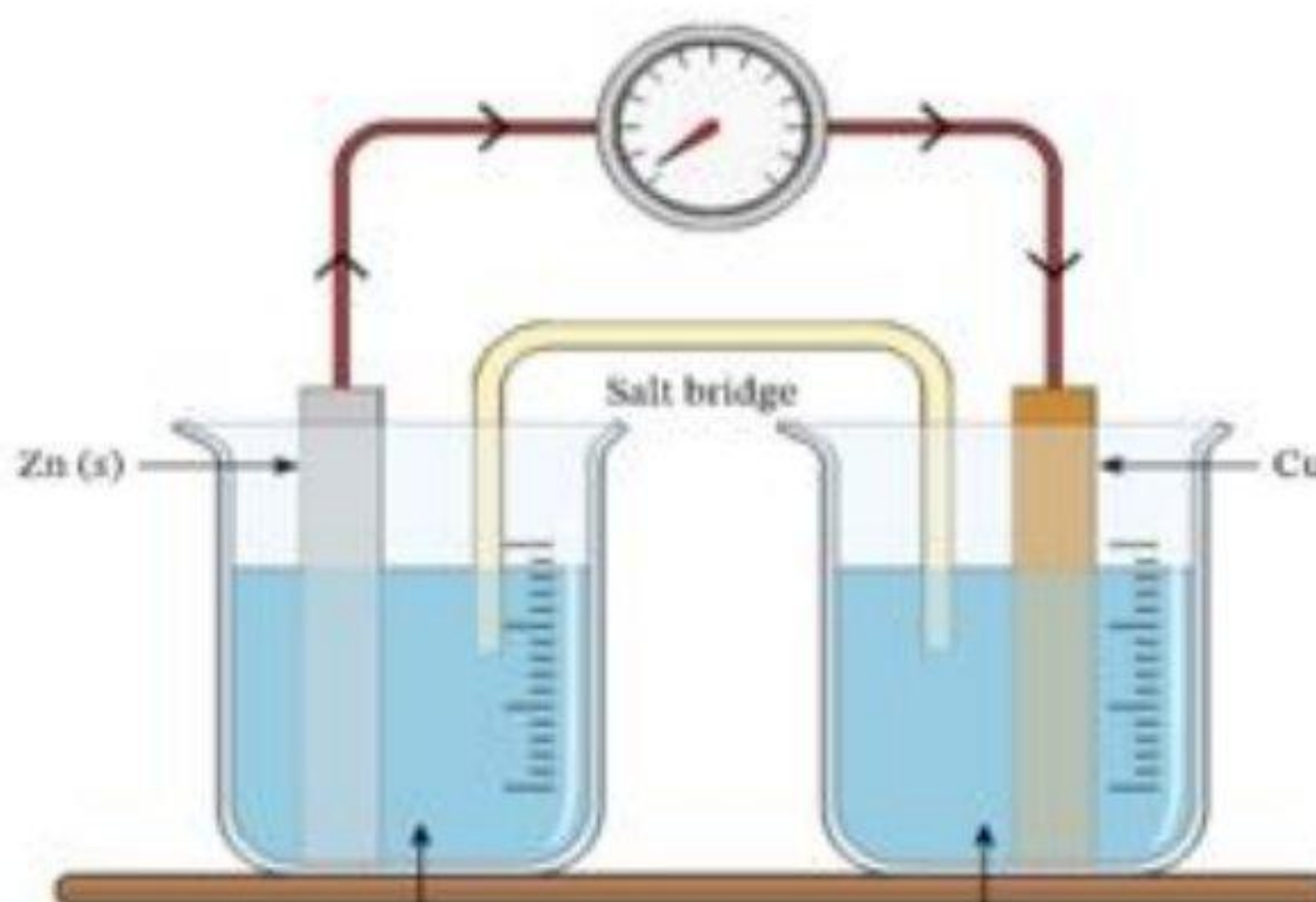

23. If you know that, the standard reduction potentials of ( $\text{Ni} = -0.23\text{V}$ ), ( $\text{Fe} = -0.41\text{V}$ ), ( $\text{Cu} = +0.34\text{V}$ ), ( $\text{Al} = -1.67$ )

- a) Copper oxidized aluminum and doesn't oxidize iron.
- b) Nickel reduced iron and doesn't reduce copper.
- c) Aluminum oxidized iron and doesn't oxidize copper.
- d) Iron oxidized aluminum and reduced nickel.

24. You have oxidation potentials of some elements, which of them is the best reducing agents?

- a) 3 volts
- b) 2.3 volts
- c) Zero volts
- d) -2.8 volts

25. The IUPAC name of the following compound is:

- a) 3 – bromo hexene.
- b) 4- bromo hexene.
- c) 3 – bromo – 3 – propyl hexene.
- d) 3 – bromo – 3 – ethyl hexyne.

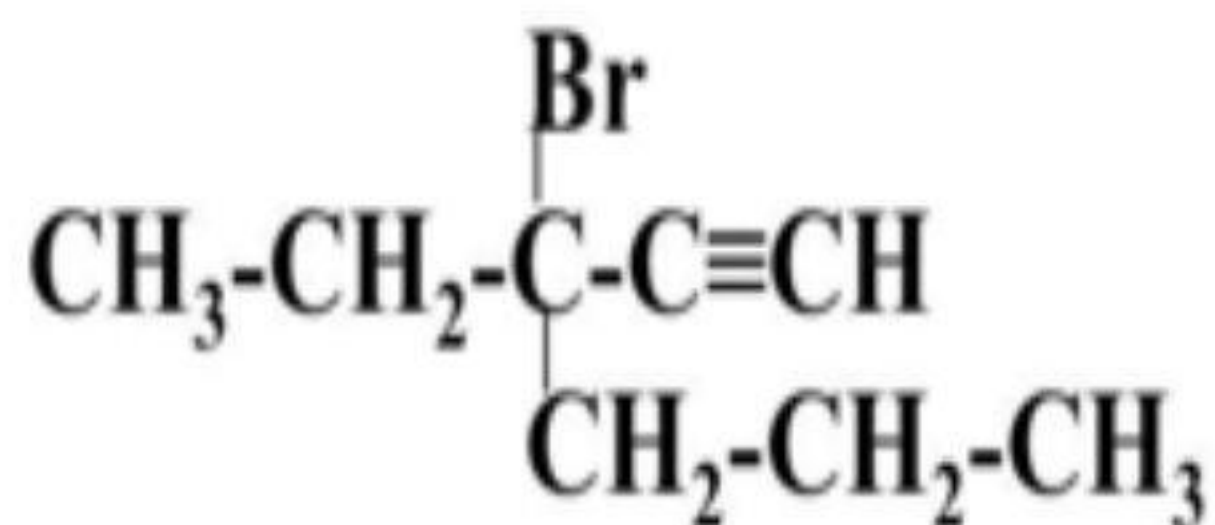

26. The IUPAC name of the following .....

- a) 3 – methyl hexan-5-ol.
- b) 4-methyl hexan-1-ol.
- c) 4-ethyl pentan-2-ol.
- d) 4-methyl-2-hexanol.

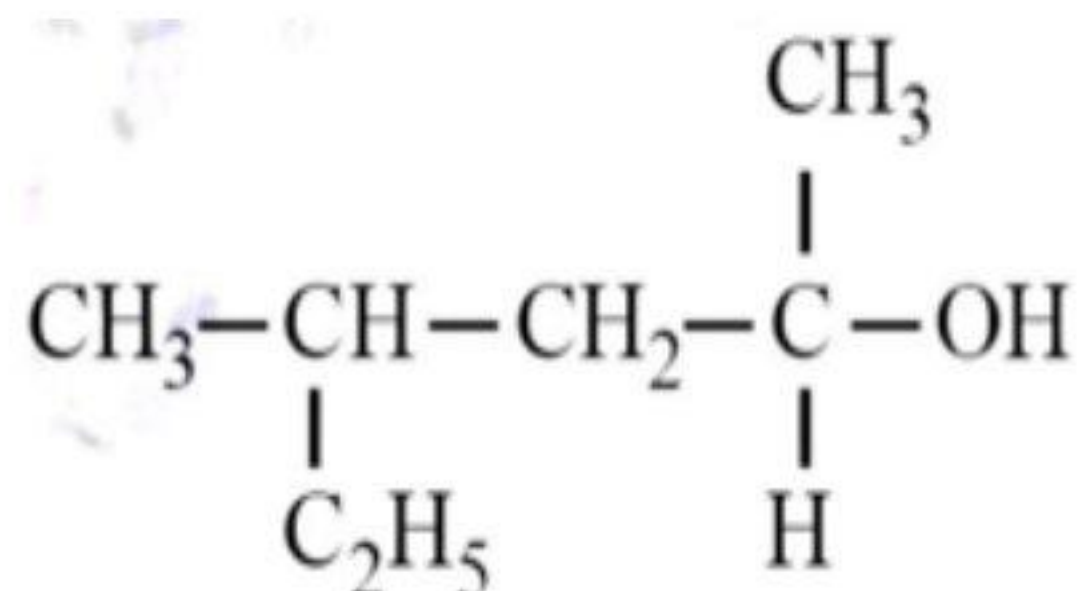

27. Which of the following pairs represent isomers .....

- a) Propanol and propanal.
- b) Pentane and 2,2-dimethyl butane.
- c) Propanone and dimethyl ether.
- d) Butanoic acid and 2-methyl propanoate.

28. Which of the following equations describes the substitution reaction of an alkane .....

- a) Alkane + Halogen → di halo alkane.
- b) Alkane + Oxygen → Carbon dioxide + Water.
- c) Alkane + Halogen → Haloalkane + Hydrogen halide.
- d) Alkane + Hydrogen halide → Haloalkane + Water.

29. Which of the following reagents used to detect the double bond of alkenes:

- a) Hydrogen peroxide.
- b) Combustion in air.
- c) Bromine water.
- d) Hydrolysis in acidified water.

30. Consider the reaction of 1- butene with HCl:

What is the major product .....

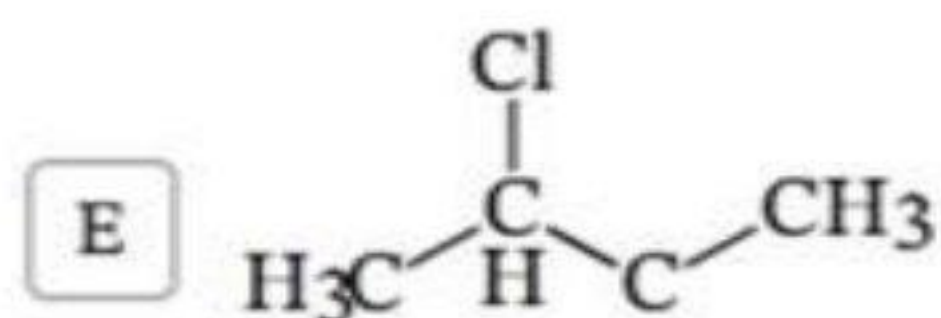
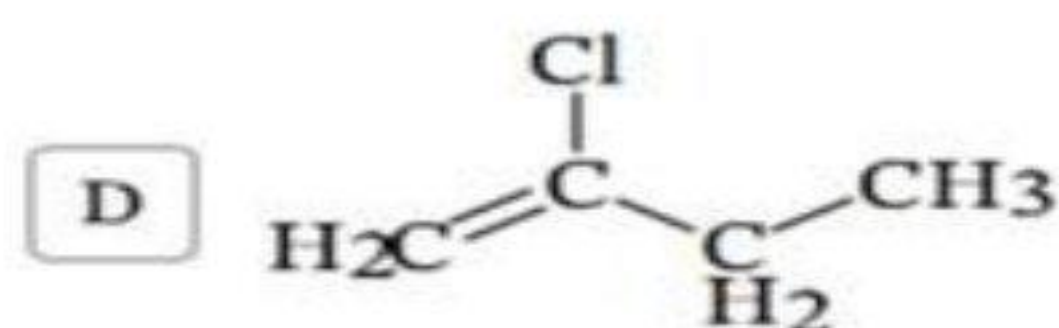
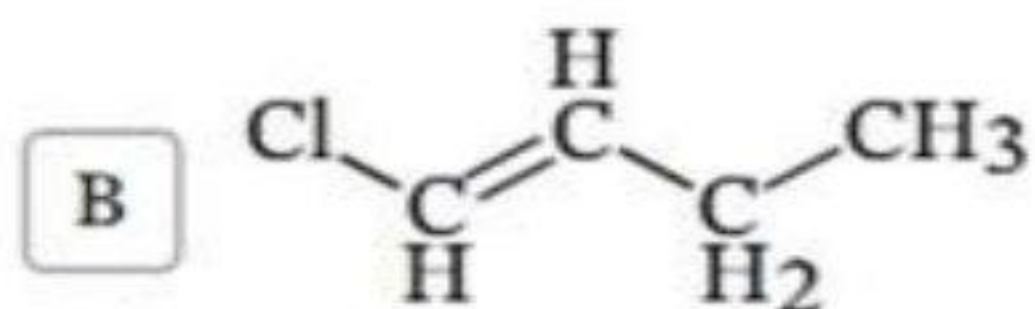
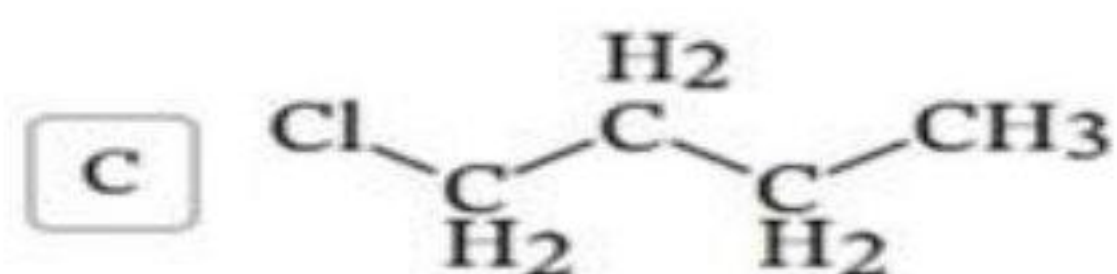
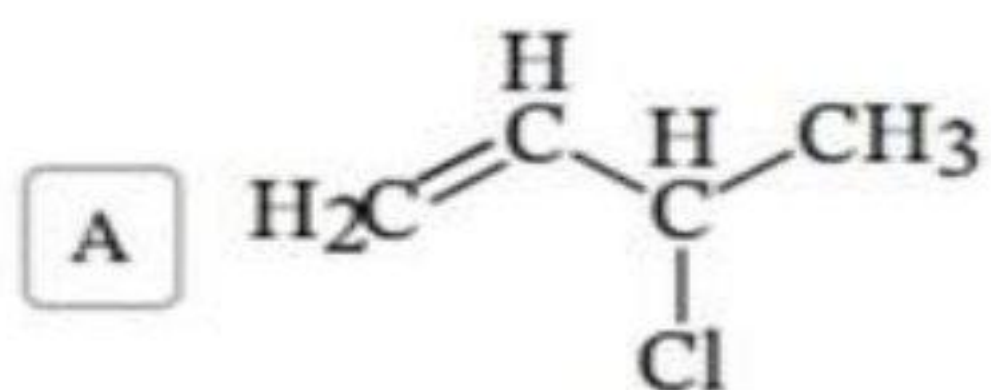
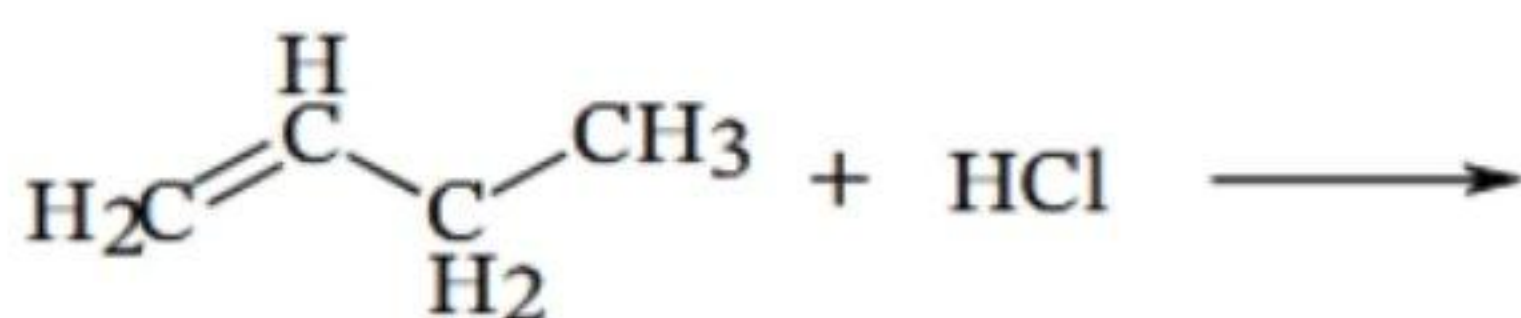

31. Which of the following is correct in, burning ethyne gas in atmospheric air?

- a) Carbon dioxide completely formed.
- b) Forming smoky flam.
- c) Forming highly thermal flam.
- d) Carbon monoxide totally forming carbon dioxide.

32. Which of the following is the correct product for the following reaction?

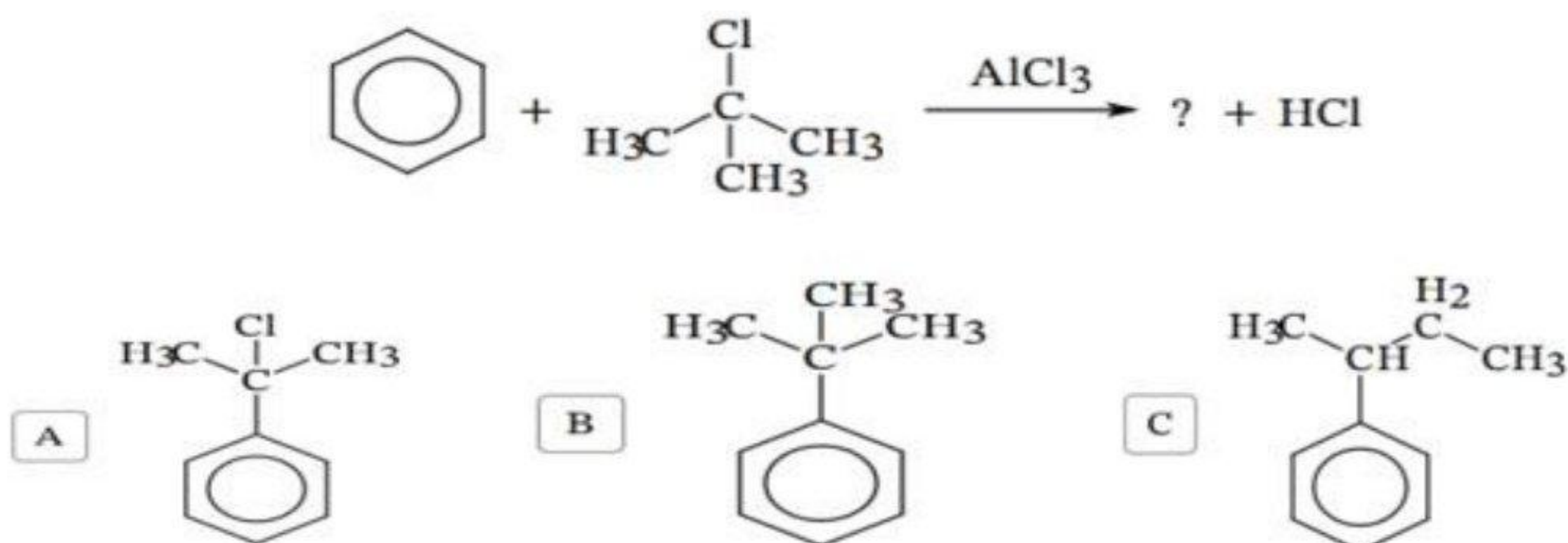

33. Which of the following consecutive combinations will lead to obtaining cyclohexane from normal hexane:

- a) Catalytic reforming followed by oxidation.
- b) Polymerization followed by reduction.
- c) Polymerization followed by oxidation.
- d) Catalytic reforming followed by reduction.

34. Which two compounds would react to give the following compound?

- a) Benzene and sulphur dioxide.
- b) Benzene and sulphuric acid.
- c) Toluene and sulphuric acid.
- d) Toluene and hydrogen sulphide.

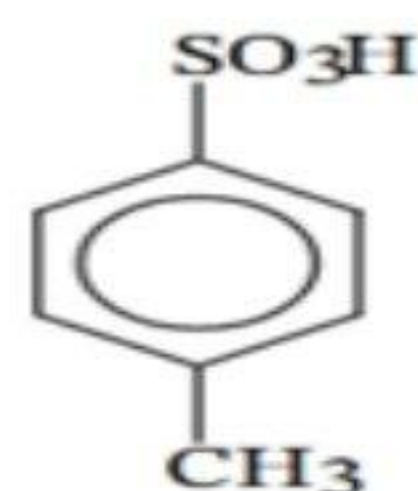



39. Which of the following reagents could be used to differentiate between aspirin and marookh oil?

- a) Sodium carbonate.
- b) Sodium hydroxide solution.
- c) Sodium bromate.
- d) Ethyl alcohol solution.

40. A, B and C are three organic compounds:

- Compound (A) reacts with HCl, but does not react with NaOH.
- Both (B) and (C) react with NaOH and do not react with HCl.
- Only compound (B) gives effervescence on reacting with  $\text{NaHCO}_3$ .

Identify the organic families that A, B and C belong to:

(a)	(A) Phenol	(B) Alcohol	(C) Acid
(b)	(A) Alcohol	(B) Phenol	(C) Acid
(c)	(A) Alcohol	(B) Acid	(C) Phenol
(d)	(A) Phenol	(B) Acid	(C) Phenol

41. Heating ethyl alcohol with concentrated sulphuric acid in different conditions, give three different products, which of these products respond to the polymerization by addition.

- a) Di ethyl ether.
- b) Acetone.
- c) Ethylene.
- d) Ethyl hydrogen sulphate.

42. Calculate the volume of water that should be added to 1L of 0.05 M HCl acid in order for its pH value to become 2:

- a) 1 L
- b) 4 L
- c) 5 L
- d) 9 L

43. The compounds which can be similar in physical and chemical character

- a)  $C_{20}H_{42}$  and  $C_{18}H_{38}$ .
- b)  $C_8H_{18}$  and  $C_{18}H_{38}$ .
- c)  $C_3H_6$  and  $C_{15}H_{32}$ .
- d)  $C_6H_{12}$  and  $C_6H_6$ .

44. (A) and (B) are two aliphatic compounds, compound (A) produced from acidic hydrolysis of aspirin while compound (B) used in condensation reaction to prepare Dacron fibers.

- a) Acetic acid, ter phthalic acid.
- b) Salicylic acid, ter phthalic acid.
- c) Acetic acid, ethylene glycol.
- d) Salicylic acid, ethylene glycol.



➤ **Second: answer the following essay questions:**

45. Study the following figure:

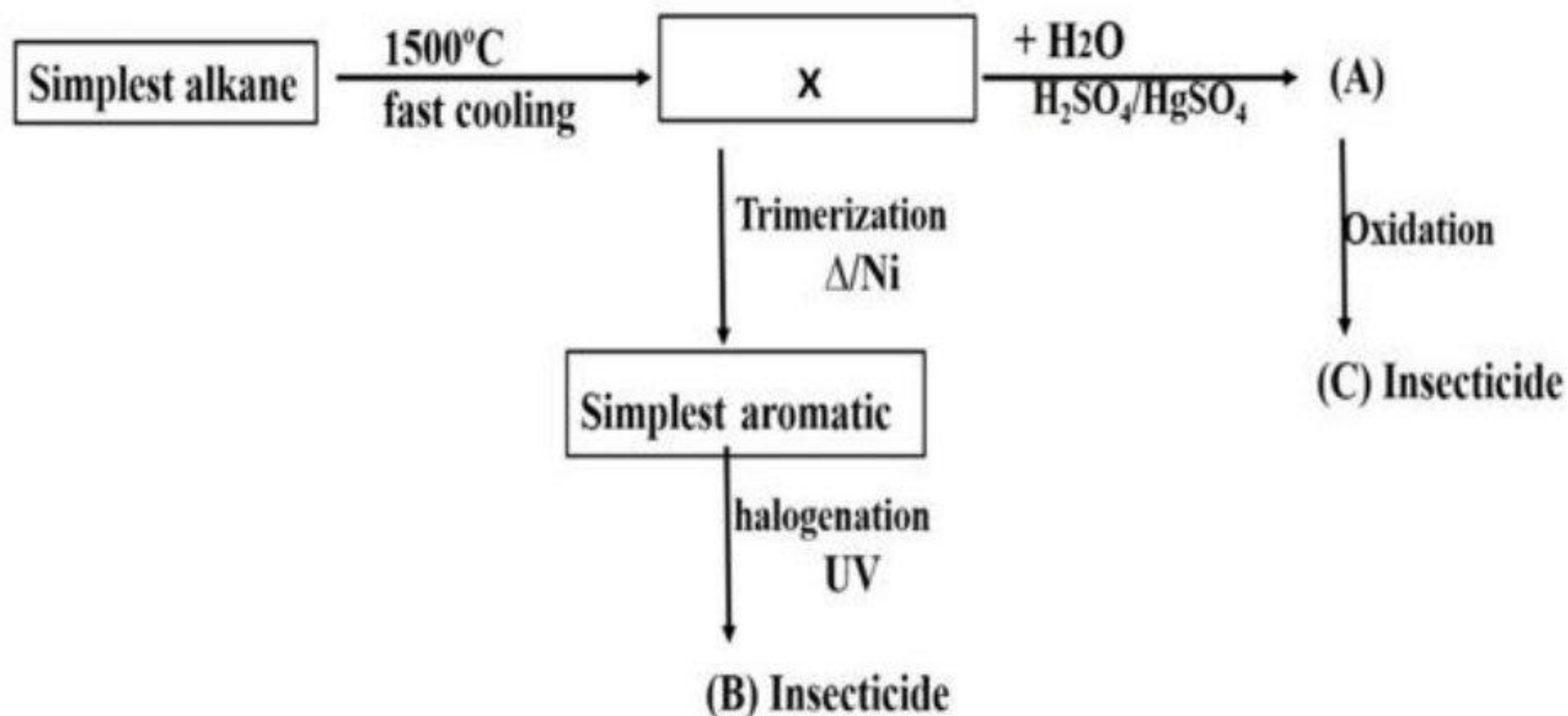

- What are the names of compound (B) and (C)?

.....  
.....

- What is the name of compound produced from reduction of (A)?

.....  
.....

- Write the polymer obtained from adding 1 mole of HCl to compound X.

.....  
.....

46. What is the similarity and difference between copper and zinc ions in CuCl and ZnSO<sub>4</sub> respectively.

.....  
.....  
.....  
.....

## expermental exam 2025- model (1)

➤ First: choose the correct answer:

Element (X) is from 1<sup>st</sup> transition series and followed by element (Z) in the series, Z is the most difficult to be oxidized from  $Z^{2+}$  to  $Z^{3+}$ . The element (X) is:

- a) Fe
- b) Mn
- c) Cu
- d) Zn

2. Which of the following transition elements has lowest third ionization potential?

- a) Ni
- b) Cr
- c) Mn
- d) Co

3. The process that take place in the extraction of iron from iron ore follows the following sequence:

- a) Roasting-Crushing- reduction
- b) Crushing-oxidation-roasting
- c) Sintering-reduction-steel production
- d) Crushing-sintering-reduction

4. Which of the following are the correct f steps to convert iron (II) sulphate to iron?

- a) Oxidation - reduction - thermal decomposition
- b) Thermal decomposition - oxidation - reduction
- c) Reduction - oxidation - thermal decomposition
- d) Thermal decomposition – reduction

5. Which of the following is the product from passing water vapor on red-hot iron and then adding a concentrated acid to the resulting substance?

- a) Iron (II) salts and water
- b) Iron (III) salts and water
- c) Iron (II) salts and Iron (III) salts only
- d) Iron (II), Iron (III) salts and water





11. Which of the following pairs can be used to detect the ions of calcium chloride salt in its solution by using solutions of?

- a) Silver nitrate – sodium hydroxide
- b) Barium chloride – sodium nitrate
- c) Barium sulphate – ammonium hydroxide
- d) Silver nitrate – sodium sulphate

12. Three samples of solution (X), the following experiments done to each:

1- Adding dil. HCl to solution	No reaction
2- Adding diluted sulphuric acid	No reaction
3- Adding excess NaOH and filtration	No ppt. is formed

So, the solution may contain cation:

- a)  $\text{Ag}^+$
- b)  $\text{Pb}^{2+}$
- c)  $\text{Fe}^{2+}$
- d)  $\text{Al}^{3+}$

13. A solution containing (1 g) of impure sodium hydroxide, 40 ml of 0.1 M hydrochloric acid was needed to titrate it, what is the percentage of impurities in the sample?

- a) 16%
- b) 32%
- c) 64%
- d) 84%

14. Which one of the following reactions is irreversible?

- a)  $2\text{NO}_{(g)} + \text{O}_{2(g)} = 2\text{NO}_{2(g)}$  (Closed vessel)
- b)  $\text{CH}_3\text{COOH}_{(l)} + \text{C}_2\text{H}_5\text{OH}_{(l)} = \text{CH}_3\text{COOC}_2\text{H}_5_{(aq)} + \text{H}_2\text{O}_{(l)}$
- c)  $\text{HCl}_{(aq)} + \text{NaOH}_{(aq)} = \text{NaCl}_{(aq)} + \text{H}_2\text{O}_{(l)}$
- d)  $\text{N}_{2(g)} + 3\text{H}_{2(g)} = 2\text{NH}_{3(g)}$  (Closed vessel)

15. In the following equilibrium reaction



- The value of  $K_p$  for decomposition of 92 gm of  $\text{N}_2\text{O}_4$  equals: (N=23, O = 16)

- a) 40
- b)  $2.5 \times 10^{-3}$
- c)  $5 \times 10^{-2}$
- d) 0.22

16. At equilibrium  $A + B \rightleftharpoons 2C$ , the equilibrium constant  $K_c = 0.04$ , which of the following are the final concentrations of A , B and C at equilibrium?

	[A] (M)	[B] (M)	[C] (M)
a)	0.89	0.02	0.33
b)	0.5	0.89	0.02
c)	0.89	0.89	0.18
d)	0.48	0.48	0.52

17. The ionization constant ( $K_a$ ) of four acids are provided in the table below.

- Arrange the in ascending order according to pH

- a) (Q) < (P) < (S) < (R)
- b) (P) < (Q) < (R) < (S).
- c) (R) < (S) < (P) < (Q).
- d) (Q) < (S) < (P) < (R).

Acid	$K_a$	Ca
(P)	$3.2 \times 10^{-4}$	0.01
(Q)	$2.5 \times 10^{-6}$	0.2
(R)	$9.8 \times 10^{-2}$	0.02
(S)	$5.6 \times 10^{-5}$	0.4

18. If the solubility product ( $K_{sp}$ ) of the salt  $AB_3$  is  $2.7 \times 10^{-11}$ , what is the concentration of  $[B^-]$  in the solution?

- a)  $3 \times 10^{-4}$  M
- b)  $27 \times 10^{-3}$  M
- c)  $1 \times 10^{-3}$  M
- d)  $3 \times 10^{-3}$  M

19. For the following saturated solution :

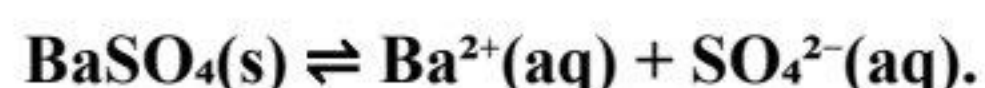

Which of the following salts solutions does not change the equilibrium state?

- a)  $K_2SO_4$  (aq)
- b) NaCl (aq)
- c)  $Ba(NO_3)_2$  (aq)
- d)  $H_2SO_4$  (aq)

20. In the reaction  $A + B \rightleftharpoons C + D$ , the values of the equilibrium constant ( $K_c$ ) at two different temperatures were:

$$- K_c = 50 \quad \text{at } 27^\circ C \quad K_c = 10 \quad \text{at } 120^\circ C$$

Which of the following statements is correct?

- a) The reaction shifts forward as temperature increases.
- b) The reaction shifts backward as pressure increases.
- c) The reaction is not affected by temperature changes.
- d) This reaction is exothermic.

21. if degree of ionization of  $\text{NH}_4\text{OH} = 1.8 \times 10^{-5}$ , the number of ionized moles in 500 ml of 0.2 M equals:

- a)  $1.8 \times 10^{-5}$
- b)  $3.6 \times 10^{-5}$
- c)  $3.6 \times 10^{-4}$
- d)  $1.8 \times 10^{-6}$

22. The following reaction occurs in a electrochemical cell:

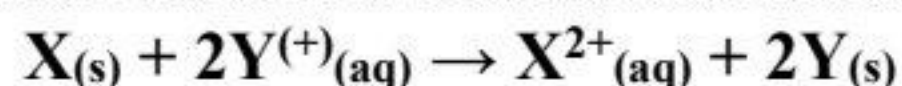

If:  $\text{X}^{2+}_{(aq)} \rightarrow \text{X}_{(s)}$ ,  $E^\circ = -0.56 \text{ V}$ ,  
 $\text{Y}^{+}_{(aq)} \rightarrow \text{Y}_{(s)}$ ,  $E^\circ = +0.23 \text{ V}$ ,

So the cell is:

- a) Galvanic and e.m.f.= 0.23 volt
- b) Galvanic and e.m.f.= 0.79 volt
- c) d) Electrolytic and e.m.f.= - 0.23 volt
- d) d) Electrolytic and e.m.f.= - 0.79 volt

23. The half-reaction that occurs at the anode during electrolysis of molten sodium bromide is:

- a)  $2\text{Br}^- \rightarrow \text{Br}_2 + 2 e^-$
- b)  $\text{Br}_2 + 2 e^- \rightarrow 2 \text{Br}^-$
- c)  $\text{Na}^+ + e^- \rightarrow \text{Na}$
- d)  $\text{Na} \rightarrow \text{Na}^+ + e^-$

24. If one mole of electrons is passed through molten of  $\text{MgSO}_4$ ,  $\text{AgNO}_3$  and  $\text{AlCl}_3$ , connected in series, the proportion of moles precipitated from Mg, Ag and Al is (Ag=108, Mg=24, Al=27)

	Mg	Ag	Al
A	3	2	6
B	24	108	27
C	3	1	2
D	3	6	2

25. Which of the following makes the Mercury cell stop working?

- a) Increase in the temperature of the cell
- b) Concentration of electrolytes in is different.
- c) All ions in the cathode half-cell are consumed
- d) Two electrodes corrode completely

26. If a current of 0.5 A is passed for 20 minutes through molten NaCl, the volume of produced gas at STP is: (Na=23.Cl=35.5 )

- a) 19.6 ml
- b) 22.4 ml
- c) 69.7 ml
- d) 445 ml

27. Zn is used in anodic protection of iron because:

- a)  $E^\circ(\text{Zn}^{2+} / \text{Zn}) > E^\circ(\text{Fe}^{2+} / \text{Fe})$
- b)  $E^\circ(\text{Zn}^{2+} / \text{Zn}) < E^\circ(\text{Fe}^{2+} / \text{Fe})$
- c) Zn is cheaper than iron.
- d) Zn does react easily with air.

28. Which of the following is correct in charging a lead-acid battery?

- a) Lead is converted to lead oxide at the cathode.
- b) Lead is converted to lead sulphate at the cathode.
- c) Lead sulphate is converted to lead oxide at the anode.
- d) Lead sulphate is converted to elemental lead at the anode.

29. A fuel cell differs from other galvanic cells because it:

- a) Operates on oxidation and reduction reactions.
- b) Stores reactants inside the cell for a long period.
- c) Acquires fuel from an external source.
- d) Has a higher total cell voltage compared to other cells.

30. If you have the following compounds:

- (X): high boiling point and sparingly soluble in water
- (Y): Used to detect water
- (Z): Starting material in preparation aspirin

Choose what is X ,Y and Z

	(X)	(Y)	(Z)
a)	Acetic acid	Copper oxide	ethanol
b)	Formic acid	Copper sulphate	Toluene
c)	Benzoic acid	Copper sulphate	Salicylic acid
d)	propanol	Magnesium sulphate	benzene

31. Which of the following is the correct IUPAC name of the following compound?

- a) 3-ethyl-5-bromo-3-heptene
- b) 5-bromo-3-ethyl-3-heptene
- c) 3-bromo-5-ethyl-4-heptene
- d) 1,1-diethyl-3-bromo-1-pentene

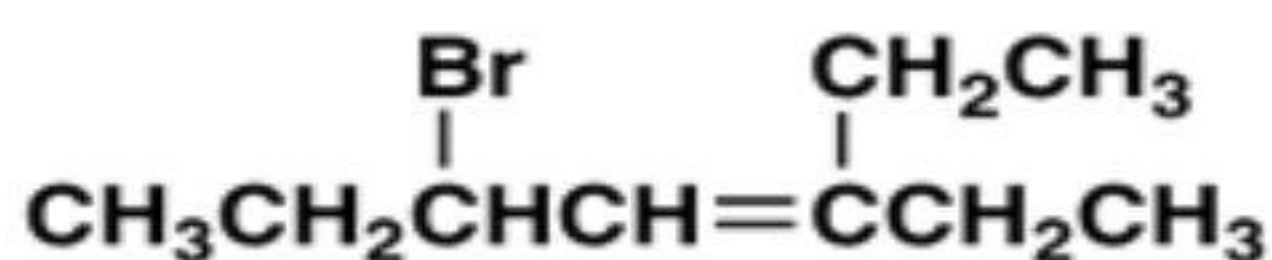

32. Number of isomers that can be oxidized for molecular formula  $\text{C}_4\text{H}_{10}\text{O}$  is:

- a) 2
- b) 3
- c) 4
- d) 5

33. Catalytic dehydration of 2-methyl -1-propanol then Catalytic hydration of the product gives:

- a) Ketone
- b) Aldehyde
- c) Tertiary alcohol
- d) Primary alcohol

34. A compound (X) with the molecular formula  $\text{C}_3\text{H}_8\text{O}$  can be oxidized to another compound Y whose molecular formulae is  $\text{C}_3\text{H}_6\text{O}_2$ . The compound X may be:

- a)  $\text{CH}_3\text{CH}_2\text{OCH}_3$
- b)  $\text{CH}_3\text{CH}_2\text{CHO}$
- c)  $\text{CH}_3\text{CH}_2\text{CH}_2\text{OH}$
- d)  $\text{CH}_3\text{CHOHCH}_3$

35. The correct sequence for preparing alkane from an alcohol is:

- a) Oxidation  $\rightarrow$  Hydrolysis  $\rightarrow$  Reduction
- b) Hydrolysis  $\rightarrow$  neutralization  $\rightarrow$  dry distillation
- c) Oxidation  $\rightarrow$  Hydrolysis  $\rightarrow$  Reduction
- d) Oxidation  $\rightarrow$  neutralization  $\rightarrow$  dry distillation

36. Which of the following has no effect on acidified potassium dichromate?

- a) ethanol
- b) Ethanal
- c) 2-propanol
- d) Propanone

37. To obtain the following compound from benzene, the last process is:

- a) Nitration
- b) Polymerization
- c) Alkylation
- d) Oxidation

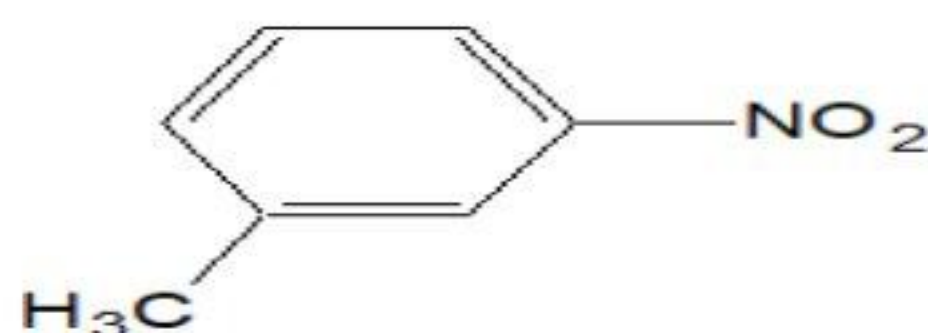

38. Number of sigma bonds in 1,2-dimethyl benzene is:

- a) 12
- b) 16
- c) 18
- d) 20

39. Which of the following is the most acidic compounds?

- a)  $C_6H_5COOH$
- b)  $CH_3COOH$
- c)  $CH_3CH_2COOH$
- d)  $CH_3(CH_2)_2COOH$

40. Meta-chloro-benzoic acid can be obtained from ethyne by:

- a) Polymerization → Oxidation → Halogenation → Alkylation
- b) Polymerization → Alkylation → Oxidation → Halogenation
- c) Alkylation → Polymerization → Halogenation → Oxidation
- d) Oxidation → Polymerization → Halogenation → Alkylation

41. Molecular formula  $C_6H_{12}$  represents three cyclic aliphatic hydrocarbons: X, Z and W

- X: Does not contain methyl groups.
  - Z: Contains one group ( $-CH-$ ).
  - W: Contains two methyl groups.
- Arrange these compounds in increasing order of activity:
- a)  $X < Z < W$
  - b)  $Z < W < X$
  - c)  $X < W < Z$
  - d)  $W < X < Z$

42. Which of the following steps can be required to obtain Benzoic acid from sodium benzoate?

- a) Dry distillation → Chlorination → Alkylation → Oxidation
- b) dry distillation → Alkylation → Oxidation
- c) hydration → Chlorination → Alkylation → Oxidation
- d) Alkylation → Oxidation → Chlorination

43. If you know that (A) and (B) react with sodium hydroxide.

- (C) doesn't react with alcohol.

Which of the following choices is correct?

- a) (A): Benzene, (C): 2-methyl-2-Propanol.
- b) (C): Benzene, (B): Ethyl alcohol.
- c) (A): Propanoic acid, (B): di-Methyl ether.
- d) (A): Ethanoic acid, (C): Phenol.

44. During the hydrolysis of butyl butanoate in alkaline medium.

Which of the following is an isomer for the produced alcohol?

- a) Butanoic acid
- b) diethyl ether
- c) 1-butanol
- d) 2-methyl propanal

**Second: answer the following essay questions:**

45. What are the processes needed to convert the simplest secondary alcohol to primary alcohol?

.....  
.....  
.....  
.....  
.....

46. The following scheme represents the reactions of iron and its oxides at different conditions:

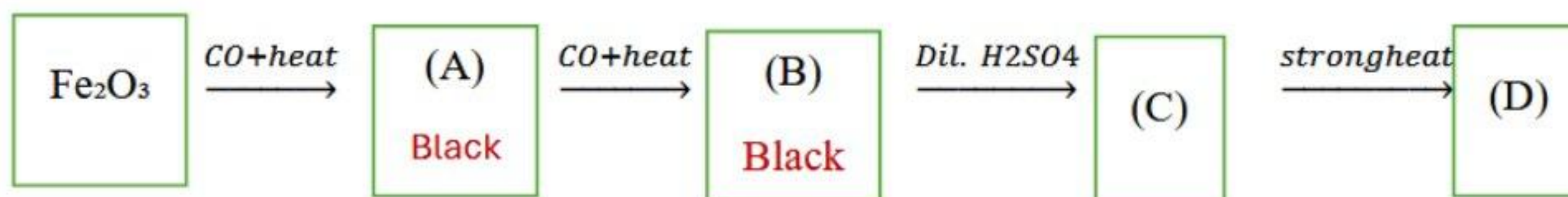

What are (A) , (B) , (C) , (D)?

.....  
.....  
.....  
.....  
.....

## expermental exam 2025- model (2)

➤ First: choose the correct answer:

1. The diagram represents the ionization energies of one of the elements from the first transition series. One of this element's compounds is used in:

- a) Leather tanning
- b) Colouring glass
- c) Preparing oxygen
- d) Fungicide

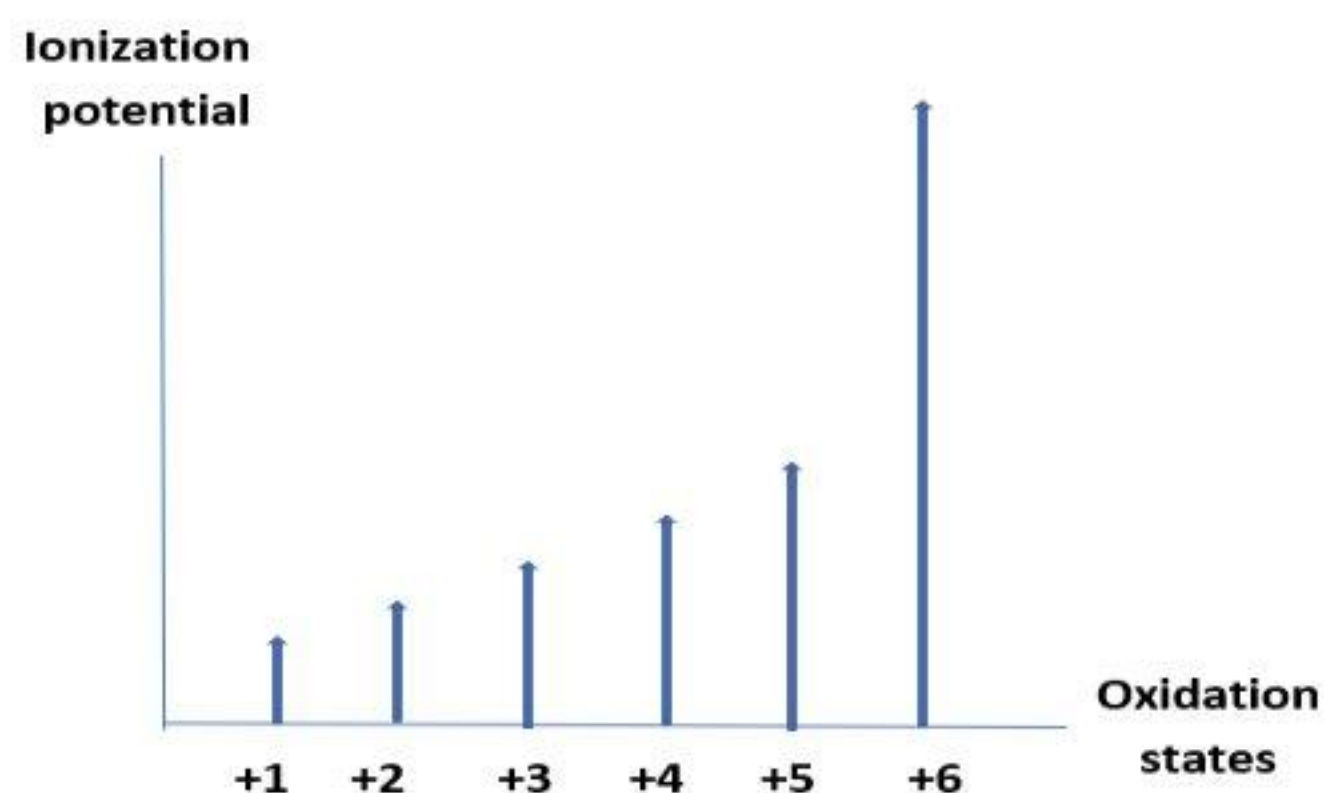

2. Three alloys are described based on their properties in the following table:

(A)	(B)	(C)
Formed by combining two elements not from the same group	Its elements have identical chemical properties and similar atomic radii	Formed by adding a percentage of carbon to iron

-These alloys are:

- a) A: interstitial , B : substitutional , C: inter-metallic
- b) A : substitutional , B: interstitial , C: inter-metallic
- c) A : inter-metallic , B: substitutional , C: interstitial
- d) A: interstitial , B: inter-metallic , C: substitutional

3. "A transition element from the first transition series in its (2+ ) oxidation state has the maximum magnetic moment. The electronic configuration of this element in the (3+ ) oxidation state is:

- a)  $4s^0, 3d^5$
- b)  $4s^2, 3d^5$
- c)  $4s^0, 3d^3$
- d)  $4s^0, 3d^4$

4. The electronic configuration of the ion  $X^{3+}$  is  $[Ar] 3d^6$ . The element X is used in:

- a) Production of ammonia gas
- b) Dry batteries
- c) Fungicides
- d) Hydrogenation of oils

5. Given the electronic configurations of some transition metal cations:



Which of the following is an easiest process?

- a) Reduction of  $Y^{3+}$  to  $Y^{2+}$
- b) Reduction of  $X^{4+}$  to  $X^{3+}$
- c) Oxidation of  $Y^{2+}$  to  $Y^{3+}$
- d) Oxidation of  $X^{3+}$  to  $X^{5+}$

6. Ammonia solution is added to iron (III) salt solution, a substance (A) With a reddish-brown colour is formed. On heating (A) above  $200^{\circ}\text{C}$ , a substance (B) is formed. When (B) is heated with carbon monoxide gas at a temperature of  $230\text{--}300^{\circ}\text{C}$ , a substance (C) is obtained. Which of the following are the substances (A, B, and C):

Choice	A	B	C
a)	$\text{Fe}(\text{OH})_2$	$\text{Fe}_2\text{O}_3$	$\text{FeO}$
b)	$\text{Fe}_3\text{O}_4$	$\text{Fe}(\text{OH})_3$	$\text{Fe}$
c)	$\text{Fe}(\text{OH})_3$	$\text{Fe}_2\text{O}_3$	$\text{Fe}_3\text{O}_4$
d)	$\text{Fe}_2\text{O}_3$	$\text{FeO}$	$\text{Fe}_3\text{O}_4$

7. When iron (II) oxalate is heated in air, a compound (A) is formed. Reducing (A) with carbon monoxide gas at a temperature higher than  $700^{\circ}\text{C}$  produces an element.

When chlorine gas is passed over this element, a compound (B) is formed. Which of the following is correct?

- a) A:  $\text{FeO}$  , B:  $\text{FeCl}_2$
- b) A:  $\text{Fe}_2\text{O}_3$ , B:  $\text{FeCl}_3$
- c) A:  $\text{Fe}_2\text{O}_3$  , B: $\text{FeCl}_3$
- d) A:  $\text{Fe}_2\text{O}_3$  , B: $\text{FeCl}_2$

8. Adding magnesium chloride solution to a salt solution produces a solution of salt (X).

On heating (X) solution produces a white precipitate. What is the anion present in X?

- a)  $\text{CO}_3^{2-}$
- b)  $\text{SO}_3^{2-}$
- c)  $\text{HCO}_3^-$
- d)  $\text{S}^{2-}$

9. When silver nitrate solution is added to a solution containing an anion whose vapors turn a paper wet with starch blue, which of the following precipitate is formed?
- A yellow precipitate soluble in ammonium solution
  - A white precipitate insoluble in acids
  - A yellow precipitate insoluble in ammonium solution
  - A white-green precipitate soluble in acids
10. Adding diluted HCl to salt (X), produces a gas with a pungent odour, turns paper wet with acidified potassium dichromate green and produces a brick-red colour in the non-luminous part of a flame. The salt (X) is:
- Calcium nitrate
  - Calcium sulphite
  - Sodium nitrite
  - Copper sulphate
11. When barium chloride solution is added to a solution of salt (X), a white precipitate is formed that dissolves in diluted acids. When an ammonia solution is added to another amount of salt (X) solution, a reddish-brown precipitate is formed. The salt (X) is:
- $\text{FeSO}_4$
  - $\text{AlPO}_4$
  - $\text{FePO}_4$
  - $\text{Na}_3\text{PO}_4$
12. 10.6 g of anhydrous sodium carbonate binds with 18 g of water to form hydrated sodium carbonate with the formula: (Na=23, C=12, O=16)
- $\text{Na}_2\text{CO}_3$
  - $\text{Na}_2\text{CO}_3 \cdot 4\text{H}_2\text{O}$
  - $\text{Na}_2\text{CO}_3 \cdot 10\text{H}_2\text{O}$
  - $\text{Na}_2\text{CO}_3 \cdot 2\text{H}_2\text{O}$

13. 0.2 g of a diprotic acid is required to titrate 100 ml of 0.1 M NaOH solution.

- The molar mass of the acid equals:-

- a) 151.28 g/mol
- b) 40 g/mol
- c) 171 g/mol
- d) 24 g/mol

14. When concentrated sulphuric acid is added to salt (X) and gently heated, gas (Y) is released, and a precipitate (Z) is formed. The substances (X, Y, and Z) are:

Choice	X	Y	Z
a)	Pb(NO <sub>3</sub> ) <sub>2</sub>	NO <sub>2</sub>	PbSO <sub>4</sub>
b)	Na <sub>2</sub> CO <sub>3</sub>	CO	Na <sub>2</sub> SO <sub>4</sub>
c)	CaCl <sub>2</sub>	Cl <sub>2</sub>	CaSO <sub>4</sub>
d)	CuBr <sub>2</sub>	Br <sub>2</sub>	CuSO <sub>4</sub>

15. Which of the following reactions shifts forward by decreasing pressure?

- a)  $H_2 + I_2 \rightleftharpoons 2HI$
- b)  $N_2 + 3H_2 \rightleftharpoons 2NH_3$
- c)  $PCl_5 \rightleftharpoons PCl_3 + Cl_2$
- d)  $N_2 + 2O_2 \rightleftharpoons 2NO_2$

16. The degree of ionization of a weak acid is 3% in a solution of concentration 0.2 mol/l.

- The pOH value of this solution is:

- a) 2.22
- b) 11.78
- c) 7
- d) 3

17. In the reaction:  $N_2 + 3H_2 \rightleftharpoons 2NH_3$ ,  $\Delta H = (-)$ . The factor that increases the decomposition of ammonia gas is:

- a) Raising the temperature
- b) Lowering the temperature
- c) Reducing the volume of the container
- d) Increasing the concentration of hydrogen gas

18. In the equilibrium reaction:  $\text{CH}_3\text{COOH} + \text{H}_2\text{O} \rightleftharpoons \text{CH}_3\text{COO}^- + \text{H}_3\text{O}^+$

When a few drops of hydrochloric acid are added to the reaction, then:

- a) The acetate ion concentration increases, and the reaction shifts to the right.
- b) The acetate ion concentration decreases, and the reaction shifts to the left.
- c) The acetate ion concentration decreases, and the reaction shifts to the right.
- d) The acetate ion concentration increases, and the reaction shifts to the left.

19. In the following reaction:  $2\text{O}_2 + \text{N}_2 \rightleftharpoons 2\text{NO}_2$

If  $K_c=77$  at  $800^\circ\text{C}$  and  $K_c=60$  at  $480^\circ$ , then this reaction is:

- a) Exothermic, as the value of  $K_c$  increases with heating.
- b) Endothermic, as the value of  $K_c$  increases with heating.
- c) Endothermic, as the value of  $K_c$  decreases with heating.
- d) Exothermic, as the value of  $K_c$  decreases with heating.

20. According to the water ionization equation:  $2\text{H}_2\text{O} \rightleftharpoons \text{H}_3\text{O}^+ + \text{OH}^-$

When a few drops of sodium hydroxide solution are added to water, then:

- a) The pH increases, and the concentration of  $\text{H}_3\text{O}^+$  decreases.
- b) The pH decreases, and the concentration of  $\text{H}_3\text{O}^+$  increases.
- c) The pH decreases, and the concentration of  $\text{H}_3\text{O}^+$  decreases.
- d) The pH increases, and the concentration of  $\text{H}_3\text{O}^+$  increases.

21. If the solubility degree of  $\text{Ag}_2\text{S}$  is  $10^{-5}$  mol/L, then its solubility product is:

- a)  $4 \times 10^{-5}$
- b)  $4 \times 10^{-15}$
- c)  $4 \times 10^{-10}$
- d)  $4 \times 10^{-2}$

22. In the reaction:  $\text{N}_2 + \text{O}_2 \rightleftharpoons 2\text{NO}$ , if  $K_c=4$ , then the value of  $K_c$  for the reverse reaction is:

- a) 8
- b) 0.5
- c) 0.25
- d) 16

23. Which of the following options doesn't represent a cathode reaction?

- a)  $\text{Fe}^{2+} \rightleftharpoons \text{Fe}^{3+} + \text{e}^-$
- b)  $2\text{H}^+ + 2\text{e}^- \rightleftharpoons \text{H}_2$
- c)  $\text{Ag}^+ \rightleftharpoons \text{Ag} - \text{e}^-$
- d)  $\text{Cl}_2 + 2\text{e}^- \rightleftharpoons 2\text{Cl}^-$

24. The following equations represent the reduction potentials for the ions ( $\text{A}^{+2}$ ) & ( $\text{B}^{+2}$ ):



What happens when metal (A) powder is added to a solution of  $\text{BCl}_2$ ?

- a)  $\text{A}^{+2}$  is formed
- b) Metal (A) dissolves in the solution
- c) Metal (B) precipitates
- d) No reaction occurs

25. The volume of oxygen gas evolved by passing quantity of electricity 56000 C (at STP) in acidified water is: (O=16)

- a) 6.5 L
- b) 3.25 L
- c) 11.2 L
- d) 22.4 L

26. from the electrodes potentials:

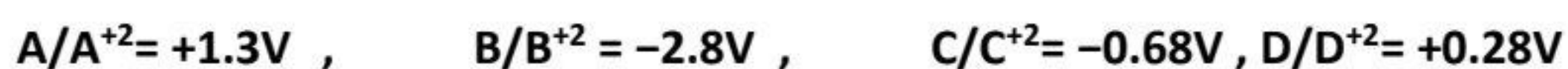

The electromotive force (EMF) of a cell formed from the strongest oxidizing agent and the strongest reducing agent is:

- a) 1.5 V
- b) 4.1 V
- c) 2.8 V
- d) 0.38 V

27. In an electrolytic cell with a  $\text{CuSO}_4$  solution using copper electrodes.

- Which of the following is correct?

- a) The mass of the anode increases, and the concentration of copper (II) ions increase.
- b) The mass of the anode decreases and the concentration of copper (II) ions does not change.
- c) The mass of the anode decreases, and the concentration of copper (II) ions increase.
- d) The mass of the cathode decreases and the concentration of copper (II) ions does not change.

28. Three different elements (A, B, C) were placed in hydrochloric acid (HCl). Element (A) and element (B), each reacted with the acid, while element (C) did not react. When element (A) was placed in a solution containing ions of element (B), it underwent corrosion.

The correct order of these elements according to their oxidation potentials is:

- a)  $A > B > C$
- b)  $B > A > C$
- c)  $C > B > A$
- d)  $A > C > B$

29. When a current of 12 A passed for 10 minutes through an electrolyte, (6) g of a divalent metallic element is deposited. The atomic mass of this element is:

- a) 150 g
- b) 110.63 g
- c) 160.83 g
- d) 55 g

30. The following diagram shows a magnesium plate in contact with water, and an iron rod wet with water.

Which of the following statements is correct?

- a) The iron acts as the cathode, and oxidation of water occurs.
- b) The iron acts as the cathode, and reduction oxygen of air occurs.
- c) The magnesium acts as the anode, and oxidation of iron occurs.
- d) The magnesium acts as the cathode, and reduction of iron occurs.

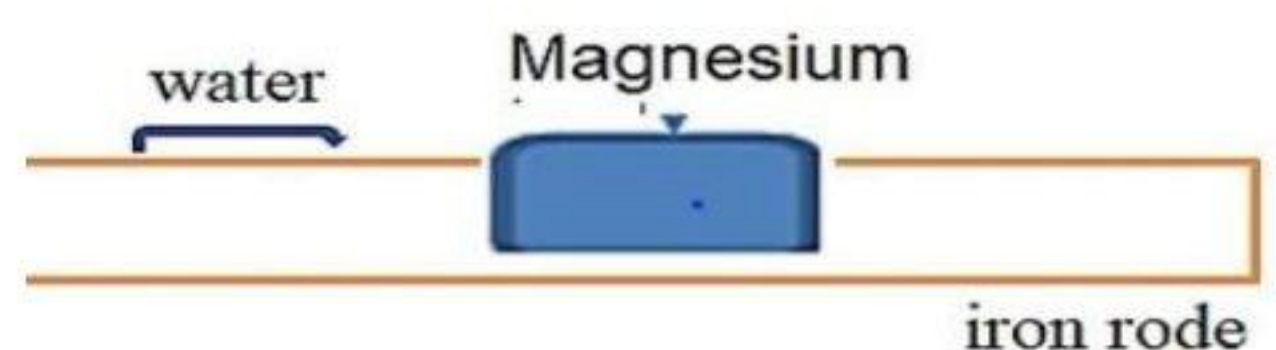

31. Performing a Bayer reaction on the compound  $\text{CH}_3\text{-CH}_2\text{-CH=CH}_2$  produces:

- a) A primary alcohol
- b) 1,2-dihydroxy-butane
- c) 1,1-dihydroxybutane
- d) Ethylene glycol

32. A trihydric alcohol has 2 primary alcohol groups and one secondary alcohol group. The nitration process of that alcohol gives:

- a) A compound used in cigarette lighters
- b) a compound that widens arteries during heart crises
- c) A compound used in hydraulic brake fluids
- d) A polyhydroxy aldehyde

33. The correct name for the compound 1, 1-dimethyl-1-butene is:

- a) 2-methyl-2-pentene
- b) 2-ethyl-pentane
- c) 3-methyl-3-butene
- d) 4-ethyl-hexane

34. When ammonia gas is passed in the isomer of methyl benzoate, The products are:

- a) Benzamide and phenol
- b) Benzamide and methanol
- c) Acetamide and phenol
- d) Acetamide and methanol

35. From the following diagram, since compound (C) is from a family of general formula  $\text{C}_n\text{H}_{2n}\text{O}_2$ , the compounds A, B, and C are:



	A	B	C
A	Ethanol	Methyl chloride	Acetaldehyde
B	1-Bromo butane	Butanol	Butanoic acid
C	Propyl chloride	Butane	Propanal
D	Ethyl chloride	Methanal	Ethanol

36. The correct order of chemical processes used to obtain carbolic acid from the simplest alkane is:

- a) Polymerization / Halogenation / Heating / Rapid cooling / alkaline hydrolysis
- b) Strong heating then rapid cooling / Polymerization / Halogenation / alkaline hydrolysis
- c) Rapid cooling / Halogenation / Polymerization / Heating / ammonolysis
- d) Halogenation / Strong heating / Polymerization / Cooling / Nitration

37. The following are three hydrocarbon derivatives:

- X: when reduced in the presence of copper (II) chromate, becomes an organic solvent
- Y: is reduced by zinc, forming the smallest aromatic compound
- Z : reacts with ammonia, forming Y and amide X

Which of the following sets of Z, Y, X is correct?

	Z	X	Y
A	Ethanol	Acetic acid	Pyrogallol
B	Acetic acid	Methyl benzoate	Propanol
C	phenyl acetate	Acetic acid	Hydroxy benzene
D	Phenol	Vinyl acetate	Acetic acid

38. What happens when 2 moles of caustic soda are added to lactic acid?

- a) It reacts with the entire quantity
- b) No reaction occurs
- c) It reacts with only one mole
- d) It becomes ethanol

39. When adding potassium permanganate in an acidic medium to compounds (A) and (B), the color disappears in the case of (A), but nothing happens in the case of (B). Which of following is correct?

- a) Compound (A) is 2-methyl-2-butanol
- b) Compound (B) results from the complete reduction of acetic acid
- c) Compound (A) is 2-propanol
- d) Compound (B) is ethanol

40. To obtain a cycloalkane from calcium carbide, the correct sequence of steps is:

- a) Reaction with water / polymerization / hydrogenation
- b) Hydrogenation / reaction with water / polymerization
- c) Add water / dry distillation / halogenation
- d) Reaction with water / hydrogenation / polymerization

41. Alcohol (X), when completely oxidized, forms the acid  $\text{CH}_3\text{-CH}_2\text{-CH=CH-COOH}$  When one mole of bromine water is added to alcohol (X), it forms:

- a) 2,3-dibromo-2-butanol
- b) 3, 3-dibromo-2-butanol
- c) 2, 3-dibromo-1-butanol
- d) 2, 3-dibromo-1-pentanol

42. The ester, which is an isomer of the compound  $\text{CH}_3\text{COOC}_2\text{H}_5$ , can be prepared from the reaction of:-

- a) Propanoic acid with methanol
- b) Acetic acid with ethanol
- c) Propanoic acid with ethanol
- d) Acetic acid with propanol

43. When adding HBr to the monomer that forms the following polymer: The product formed is:

- a) 1-chloro-1,1-dibromo-propene
- b) 1-bromo-1,1-dichloro-propane
- c) 1-bromo-1,1-dichloro-propene
- d) 1,1-dichloro-2-bromo-propane

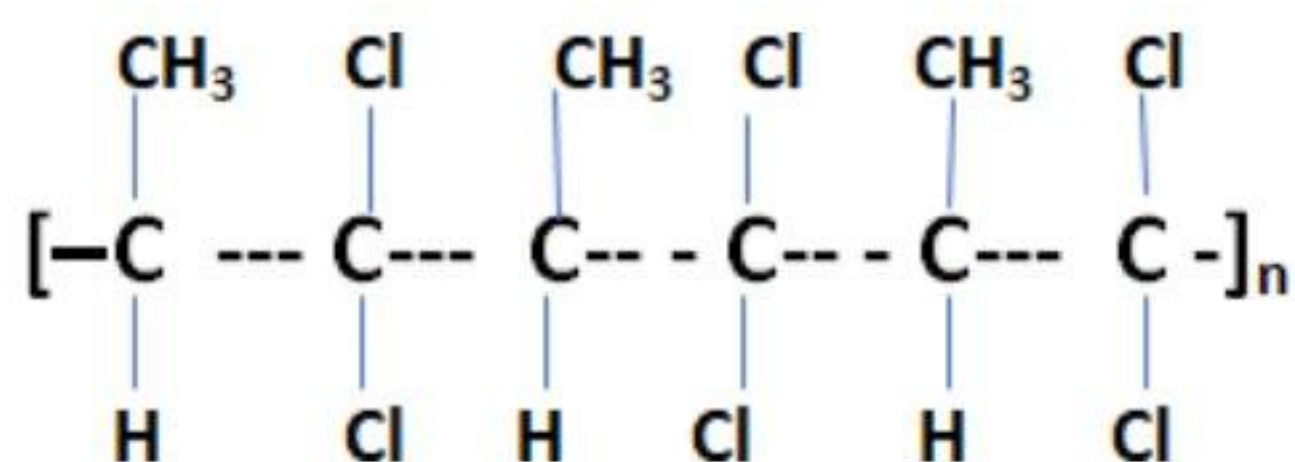

44. Using the following scheme:

Which of the following is correct?

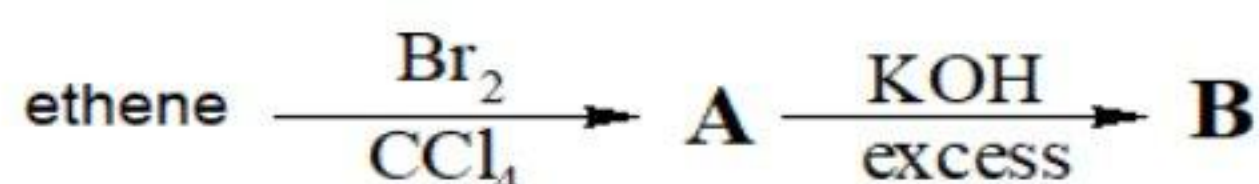

- a) (A) is bromo-ethane, (B) is ethanol
- b) (A) is 1, 1-dibromo-ethane, (B) is ethylene glycol
- c) (A) is 1, 2-dibromo-ethane, (B) is ethylene glycol
- d) (A) is bromo-ethane, B is ethanal

➤ **Second: answer the following wssay questions:**

45. Write the result of the following reactions:

A. Polymerization of ethyne gives compound (1) followed by hydrogenation of the product by addition gives compound (2):

(1) .....

(2) .....

B. The reaction of methanol with salicylic acid gives compound (3) followed by the reaction of the product with sodium hydroxide gives compound (4):

(1) The name of compound (3) is .....

(2) The structural formula of the compound (4) is: .....

(3) .....

(4) .....

46. Based on the following diagram:

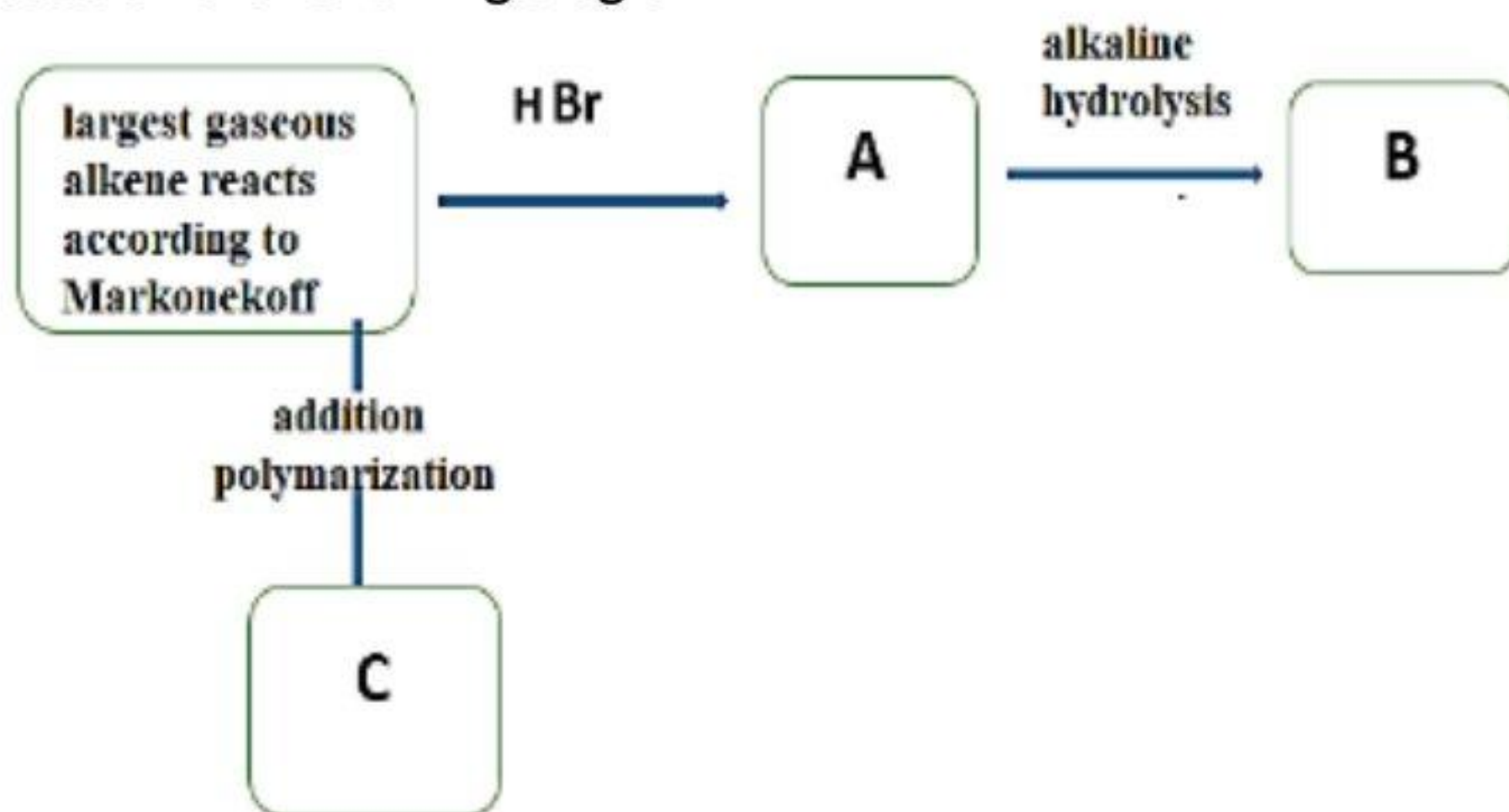

Then:

(1) The alkene is: .....

(2) Compound (A) is: .....

(3) Compound (B) is: .....

(4) Compound (C) is: .....

## experimental exam 2025- model (3)

➤ First: choose the correct answer:

1. An element of the first transition series, considered as a Para magnetic Element, has the highest density, one of its compounds is used in:-
  - a) Detecting malignant tumors.
  - b) Galvanizing metals
  - c) Sunscreen products.
  - d) Glucose detection.
  
2. Which of the following processes is easiest process?
  - a)  $\text{FeCl}_3 \rightarrow \text{FeCl}_2$
  - b)  $\text{VBr}_5 \rightarrow \text{VBr}_3$
  - c)  $(\text{MnO}_4^-) \rightarrow \text{MnO}_2$
  - d)  $\text{TiO} \rightarrow \text{TiO}_2$
  
3. Which of the following is correct regarding the properties of the following transition elements?  ${}_{21}\text{Sc}, {}_{24}\text{Cr}, {}_{26}\text{Fe}, {}_{28}\text{Ni}$ :
  - a) Ni has the highest atomic mass.
  - b) Fe has the highest density.
  - c) Cr has the lowest melting point.
  - d) Sc is the least reactive.
  
4. Which of the following processes are used to remove phosphorus from iron ore?
  - a) Electrical separation and sintering.
  - b) Crushing and reduction.
  - c) Sintering and roasting.
  - d) Roasting and concentration.
  
5. An organic compound is converted into reducing agents to be used in the reduction of iron ore in:
  - a) Midrex furnace.
  - b) Blast furnace.
  - c) Open-hearth furnace.
  - d) Electric furnace.



لضمان التفوق ابحث دائما عن موقع مدرستك

6. Which of the following is the correct order to obtain iron (III) sulfate from an organic iron salt?
- Heating in the absence of air → oxidation in hot air → reaction with dilute sulfuric acid.
  - Heating in air → reduction at 250°C → reaction with concentrated sulfuric acid.
  - Heating in the absence of air → oxidation in hot air → reaction with concentrated sulfuric acid.
  - Reduction at 250°C → reaction with dilute sulfuric acid → oxidation in hot air.
7. When a barium chloride solution is added to solutions of salts (A) and (B), a precipitate forms with salt (A) but not with salt (B). The anions of the salts are, respectively:
- Anion of salt (A): sulfate, anion of salt (B): carbonate.
  - Anion of salt (A): nitrate, anion of salt (B): bicarbonate.
  - Anion of salt (A): sulfate, anion of salt (B): nitrate.
  - Anion of salt (A): chloride, anion of salt (B): carbonate.
8. Acids (X) and (Y) are both monoprotic acids. Acid (X) can be used to detect the anion of acid (Y) in its salt. The anions of acids (X) and (Y) are:
- Anion of (X):  $\text{SO}_4^{2-}$  anion of (Y):  $\text{Cl}^-$ .
  - Anion of (X):  $\text{Cl}^-$ , anion of (Y):  $\text{NO}_2^-$ .
  - Anion of (X):  $\text{Cl}^-$ , anion of (Y):  $\text{NO}_3^-$ .
  - Anion of (X):  $\text{NO}_3^-$ , anion of (Y):  $\text{SO}_4^{2-}$ .
9. Which of the following solutions can be used to distinguish between AgI and  $\text{Ag}_3\text{PO}_4$ ?
- Sodium chloride solution.
  - Ammonia solution.
  - Silver nitrate solution.
  - Dilute hydrochloric acid.
10. Diluted hydrochloric acid can be used to detect the ions of the salts:
- $\text{FeSO}_4$ .
  - $\text{HgSO}_4$ .
  - $\text{Na}_2\text{S}$ .
  - $\text{Ag}_2\text{S}$ .

11. Which of the following ions could be separated from their salt solution by using barium chloride solutions?

- a)  $\text{Ag}^+/\text{SO}_4^{2-}$
- b)  $\text{Na}^+/\text{Ag}^+$
- c)  $\text{Cu}^{2+}/\text{PO}_4^{3-}$
- d)  $\text{K}^+/\text{Al}^{3+}$

12. A volume of water is added to a 0.8 M solution, resulting in 400 mL of a 0.2 M solution. The volume of water added is:

- a) 100 mL.
- b) 200 mL.
- c) 300 mL.
- d) 400 mL.

13. Which of the following is the number of moles of water crystallization in washing soda ( $\text{Na}_2\text{CO}_3 \cdot x\text{H}_2\text{O}$ ) if its molar mass equals 286? (Na=23, C=12, O=16, H=1.)

- a) 6.
- b) 8.
- c) 10.
- d) 12.

14. In the following reaction:  $\text{Mg}_{(s)} + \text{H}_2\text{SO}_{4(aq)} \xrightarrow{\text{dil}} \text{MgSO}_{4(aq)} + \text{H}_{2(g)}$ .

The amount of hydrogen gas in a unit of time increases by:

- a) Increasing the pressure.
- b) Increasing the container volume.
- c) Increasing sulfuric acid concentration
- d) Decreasing the temperature.

15. In the following equilibrium reaction:  $\text{A}_{2(g)} + 3\text{B}_{2(g)} \rightleftharpoons 2\text{AB}_{3(g)}$ ,  $\Delta H < 0$

Which of the following factors increases the rate of the reverse reaction?

- a) Lowering pressure and cooling.
- b) Lowering pressure and heating.
- c) Using a catalyst and cooling.
- d) Using a catalyst and reducing container volume.

16. Which of the following equations represents the following relationship?

$$K_c = \frac{1}{[Y_2]^3}$$

- a)  $2X_{(g)} + 3Y_{2(s)} \rightarrow 2XY_{3(l)}$ .
- b)  $2X_{(s)} + 3Y_{2(g)} \rightarrow 2XY_{3(s)}$ .
- c)  $2X_{(s)} + 3Y_{2(s)} \rightarrow 2XY_{3(s)}$ .
- d)  $2X_{(g)} + 3Y_{2(l)} \rightarrow 2XY_{3(l)}$ .

17. Which of the following choices is correct during the discharge of a lead-acid accumulator?

- a) The concentration of the electrolyte increases, and a lead (II) cation is formed at the anode.
- b) The concentration of the electrolyte increases, and a lead (IV) cation is formed at the cathode.
- c) The concentration of the electrolyte decreases, and a lead (IV) cation is formed at the anode.
- d) The concentration of the electrolyte decreases, and a lead (II) cation is formed at the anode.

18. The following table represents the reduction potentials of the elements X, Y, Z:

If the elements X and Y are coated with Z separately, which of the following represents the correct protection method?

Element	X	Y	Z
Reduction Potential	1.1	-2.5	-1.5

- a) Cathodic protection for X and anodic protection for Y.
- b) Anodic protection for X and cathodic protection for Y.
- c) Anodic protection for X and anodic protection for Y.
- d) Cathodic protection for X and cathodic protection for Y.

19. A current of 2 A is passed for 10 minutes through the molten oxide of a metal.

What is the volume of oxygen gas produced?

- a) 0.1392 L
- b) 0.0696 L
- c) 0.0031 L
- d) 0.0995 L

20. In the following reactions:  $\text{CH}_3(\text{CH}_2)_5\text{COONa} \xrightarrow{\text{NaOH/CaO} + \text{heat}} \text{X} + \text{A}$

- Catalytic reforming of  $\text{X} \rightarrow \text{Y}$
- Halogenation of  $\text{Y}$  in direct sunlight  $\rightarrow \text{Z}$

Which of the following describes the number of compounds resulting from the above reactions?

Option	Aliphatic Organic Compound	Aromatic Organic Compound	Inorganic Compound
A	2	0	2
B	2	1	1
C	1	1	2
D	1	2	1

21. The most acidic compound produced from:

- a) Reduction of phenol.
- b) Oxidation of ethylene in alkaline medium.
- c) Complete oxidation of methanol.
- d) Alkaline hydrolysis of alkyl halides.

22. Which of the following steps is correct to obtain para-chloro toluene from calcium carbide?

- a) Substitution halogenation  $\rightarrow$  Alkylation  $\rightarrow$  Triple polymerization  $\rightarrow$  Water addition.
- b) water addition  $\rightarrow$  Triple polymerization  $\rightarrow$  Alkylation  $\rightarrow$  Substitution halogenation.
- c) Alkylation  $\rightarrow$  Substitution halogenation  $\rightarrow$  Water addition  $\rightarrow$  Triple polymerization.
- d) Water addition  $\rightarrow$  Alkylation  $\rightarrow$  Triple polymerization  $\rightarrow$  Substitution halogenation.

23. Which of the following options is correct?

Option	Organic Compound	Number of Methyl Groups	Number of Methylene Groups
A	Methyl benzene	1	1
B	Cyclopropane	1	2
C	Methyl propane	3	0
D	Butane	3	1

24. During the polymerization of the first members of the acetylenes Which statement is correct?

- a) The number of  $\sigma$  bonds in the reactants is greater than that in the products / The total bonds in the products is greater than that in the reactants.
- b) The number of  $\sigma$  bonds in the reactants is less than that in the products / The total bonds in the products is equals to that in the reactants.
- c) The number of  $\pi$  bonds in the reactants is equal to that in the products / The total bonds in the products is equal to that in the reactants.
- d) The number of  $\pi$  bonds in the reactants is greater than that in the products / The total bonds in the products is greater than that in the reactants.

25. Which of the following reacts with calcium carbonate to form  $(C_2H_5COO)_2Ca$ ?

- a) Propanol.
- b) Butanol.
- c) Propanoic acid.
- d) Butanoic acid.

26. The following table shows the molecular formulas of three organic compounds:

Which of the following is correct?

- a) Y is mixed with gasoline and used as fuel in some countries.
- b) X is used to prepare P.E.G.
- c) Z is an acid used in the silk industry.
- d) Y is produced by esterification reactions.

Compound	Formula
X	$C_2H_6O_2$
Y	$C_3H_8O_3$
Z	$C_2H_6O$

27. Three alcohols (X, Y, and Z) shown in the table:

Which of the following is correct?

- a) X reduces to give a carboxylic acid and has a boiling point higher than Z.
- b) Y is insoluble in water and oxidizes to a dibasic acid.
- c) X has a higher boiling point than Y and doesn't oxidize under normal conditions.
- d) Z dissolves in water and does not oxidize under normal conditions.

Alcohol	Formula
X	$C_2H_5COH(CH_3)_2$
Y	$C_2H_5CHOHCH_3$
Z	$(CH_3)_2CHCH_2OH$

28. Two compounds X and Y have the following formulas:

Small piece of sodium is added to the compound (X), and hydrochloric acid is added to the compound (Y).

Which of the following is correct?

- a) No reaction occurs for X, and an aromatic halogen compound forms for Y.
- b) Sodium alkoxide forms for X, and an aromatic halogen compound forms for Y.
- c) No reaction occurs for both X and Y.
- d) Sodium alkoxide forms for X, and no reaction occurs for Y.

Compound	Formula
Aliphatic X	$C_nH_{2n+2}O$
Aromatic Y	$C_nH_nO$

29. Three organic compounds A, B and C with the same molar mass are arranged by their boiling point as follows:  $A < B < C$ . compounds (A) and (C) are isomers. Which of the following is correct?

Option	C	B	A
A	Methyl ethanoate	Ethanoic acid	1-propanol
B	Ethanoic acid	1-propanol	Methyl Methanoate
C	Ethanoic acid	1-propanol	Methyl ethanoate
D	1-propanol	Ethanoic acid	Methyl ethanoate

30. According to the following equations:

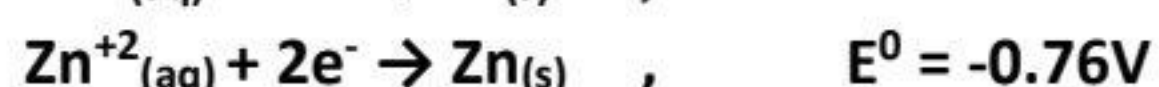
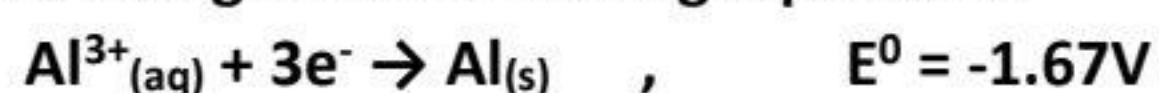

The emf for the equation:

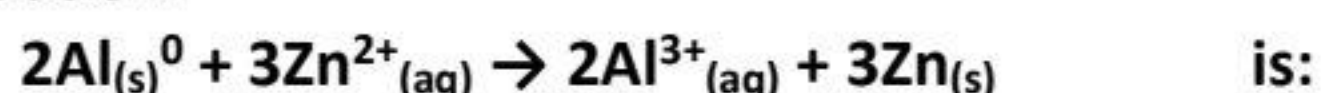

- a) +2.43 V
- b) +0.91 V
- c) -2.43 V
- d) -0.91 V

31. From the opposite table, all the following are correct, except:

- a)  $\text{A}^{+}$  is the best oxidizing agent.
- b) C is the best reducing agent.
- c) B oxidizes in the presence of A +
- d) A precedes B in the electrochemical series.

Half-reactions	Reduction Potential ( $E^{\circ}$ )
$\text{A}^{+} + \text{e}^{-} \rightarrow \text{A}^{\circ}$	+0.8 V
$\text{B}^{2+} + 2\text{e}^{-} \rightarrow \text{B}^{\circ}$	-0.26 V
$\text{C}^{+} + \text{e}^{-} \rightarrow \text{C}^{\circ}$	-2.711 V

32. Which of the following represents the possible masses of aluminium and silver deposited when the same quantity of electricity is passed through their molten salt connected in series?

[Al = 27, Ag = 108]

Options	Mass of Aluminum (g)	Mass of Silver (g)
A	24	2
B	108	27
C	2	24
D	27	108

33. The following equation represents the catalytic cracking of  $C_{18}H_{38}$ :

$C_{18}H_{38} \rightarrow n C_2H_4 + X$ , By catalytically reforming X the simplest aromatic compound is obtained.

What is the value of n?

- a) 2
- b) 4
- c) 6
- d) 8

34. A solution is prepared by dissolving 0.05 mol of strong monoprotic acid in water to make a 1000 mL solution. Which of the following is correct?

- a)  $[H^+] = 0.5 \text{ mol}$ .
- b)  $[OH^-] = 0.1 \text{ mol/L}$ .
- c)  $pH = 1.3$ .
- d)  $pOH = 1.3$ .

35. How many groups from the table are present in the compound 2-methyl-2-butene?

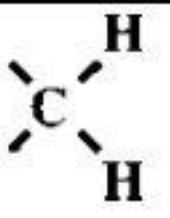
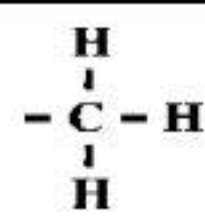
	$\text{=C-H}$		
A	2	1	2
B	2	2	1
C	1	0	3
D	1	2	1

36. What is the correct IUPAC name for the compound  $CH_3CH_2CHOHCH_2COOH$ ?

- a) 3-hydroxy pentanoic acid.
- b) 2-hydroxy pentanoic acid.
- c) ortho-hydroxy butyric acid.
- d) 3-hydroxy butyric acid.



37. In the electrolytic cell showed in the figure, copper is purified from impurities like aluminum, silver, lead, and gold under the suitable conditions. Which cations of the impurities are present in the electrolyte?

- a) Aluminum, silver.
- b) Aluminum, lead.
- c) Lead, gold.
- d) Silver, gold.

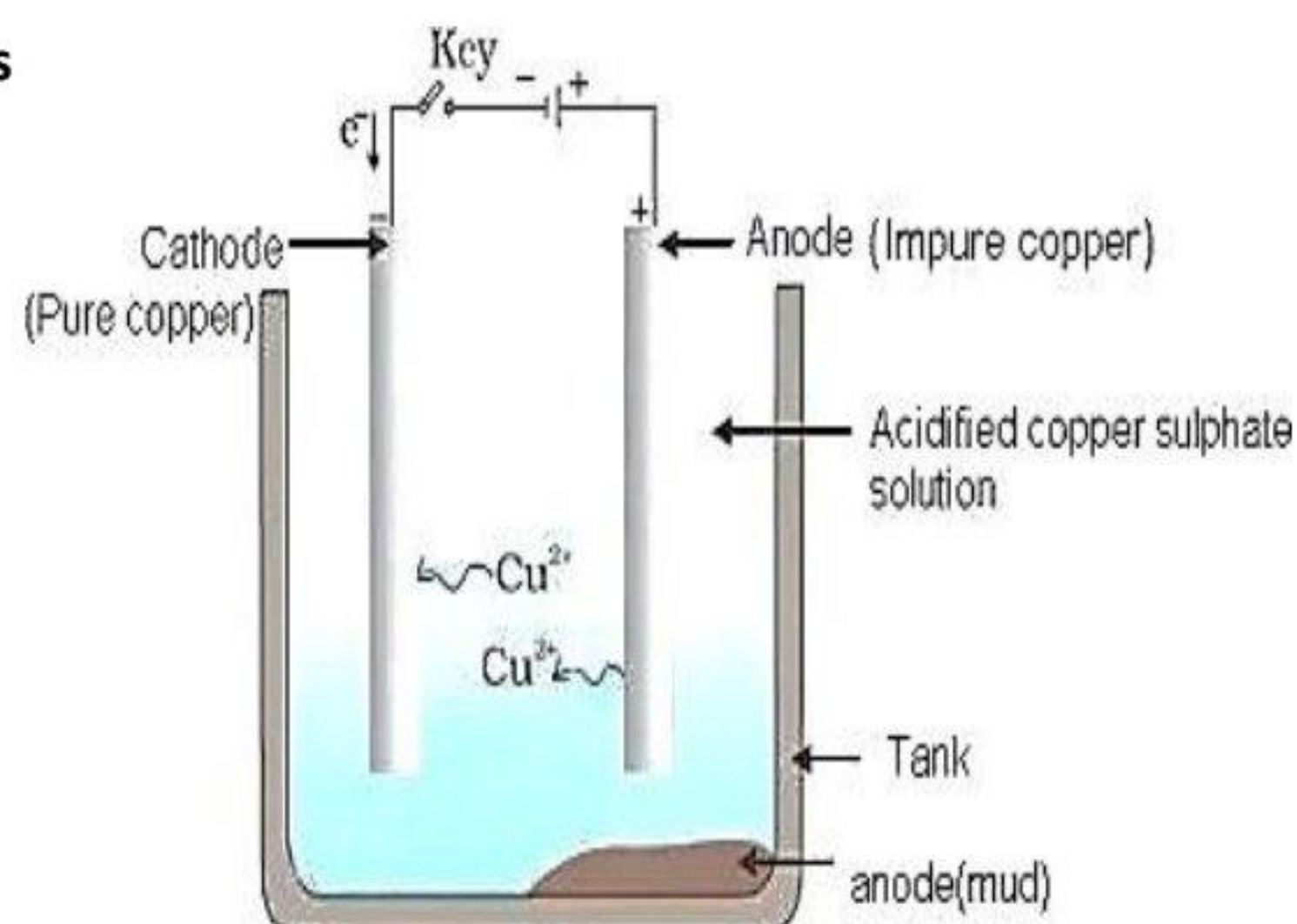

38.-(0.01) mol of NaOH is added to (1) L of distilled water (at 25°C). What is the resulting change in the pH of water?

- a) Increases by 2.
- b) Increases by 5.
- c) Decreases by 2.
- d) Decreases by 5.

39. The solubility product of  $A_2X_3$  is  $1.08 \times 10^{-23}$ . What is its degree of solubility?

- a)  $1 \times 10^{-3}$  M.
- b)  $1 \times 10^{-4}$  M.
- c)  $1 \times 10^{-5}$  M.
- d)  $1 \times 10^{-6}$  M.

40. By comparing the chemical activity of butane and cyclo butane, during their reactions with chlorine gas. Which of the following is correct?

Options	Butane	cyclobutane
A	Reactive	Reactive
B	Inactive	Inactive
C	Less reactive	More reactive
D	More reactive	Less reactive

41. Which of the following graph represents the relationship between the concentration of reactants (C) and time (t), In the reaction  $\text{BaCl}_{2(aq)} + \text{Na}_2\text{SO}_{4(aq)} \rightarrow 2\text{NaCl}_{(aq)} + \text{BaSO}_{4(s)}$

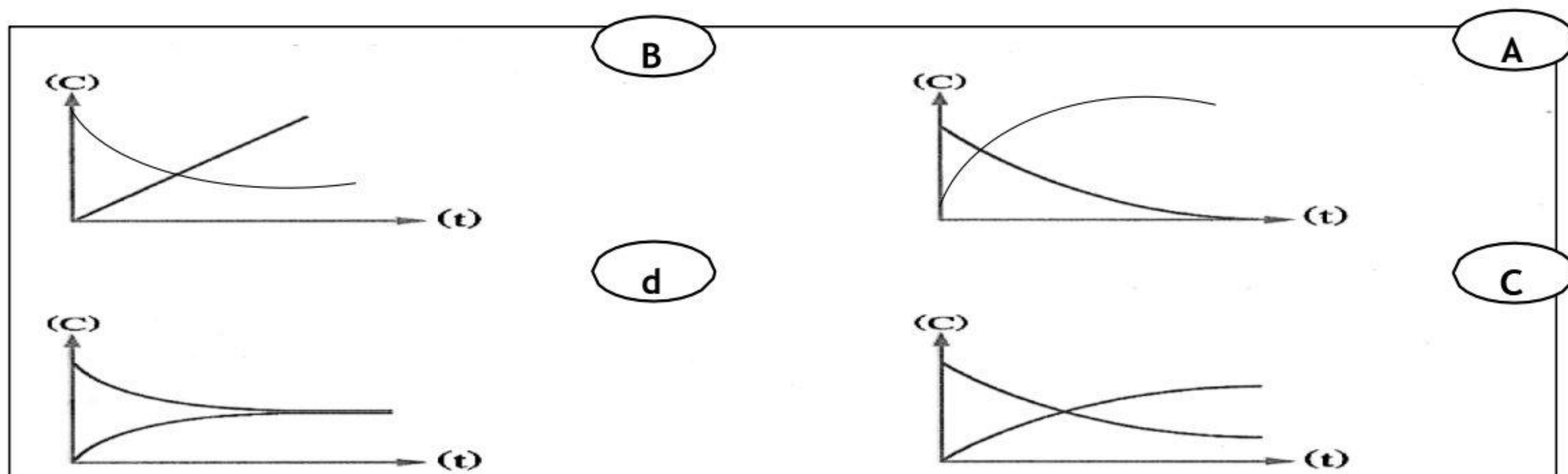

42. In the galvanic cell shown, oxidation occurs at the Cd electrode:

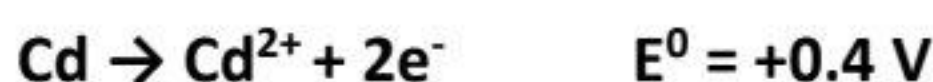

The oxidation potential of the Pb electrode is:

- a) -0.4 V
- b) +0.13 V
- c) -0.13V
- d) +0.4 V

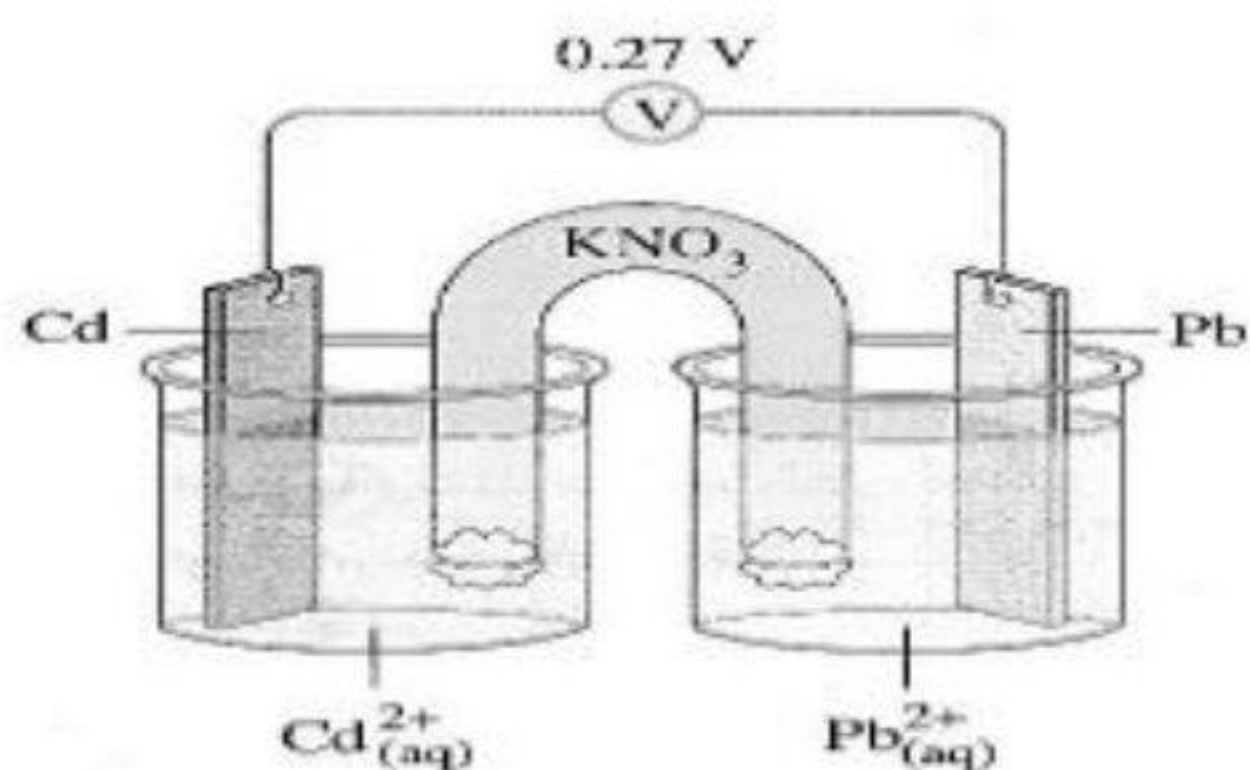

43. Based on the table below, compare the acidity of the acids at a concentration of 0.1 M:

- a) A is weaker, and pH is higher.
- b) B is stronger, and pH is higher.
- c) B is weaker, and pH is lower.
- d) A is stronger, and pH is lower.

Acid	Ka	Ionization degree
A	$3.5 \times 10^{-7}$	0.012
B	$2.1 \times 10^{-7}$	0.015

44. Study the following diagram

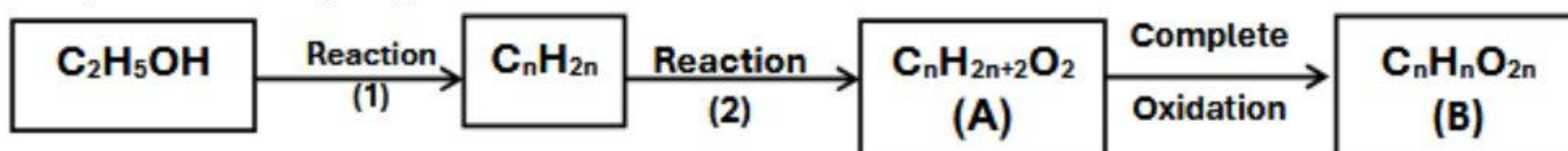

Which of the following is the correct answer?

	Reaction(I)	Compound (A)	Compound (B)
A	Dehydration	Acid	Dicarboxylic acid
B	Catalytic hydration	Acid	Dihydroxy alcohol
C	Dehydration	Glycol	Dicarboxylic acid
D	Catalytic hydration	Glycol	Dihydroxy alcohol

➤ **Second: answer the following essay questions:**

45. Study the following diagram

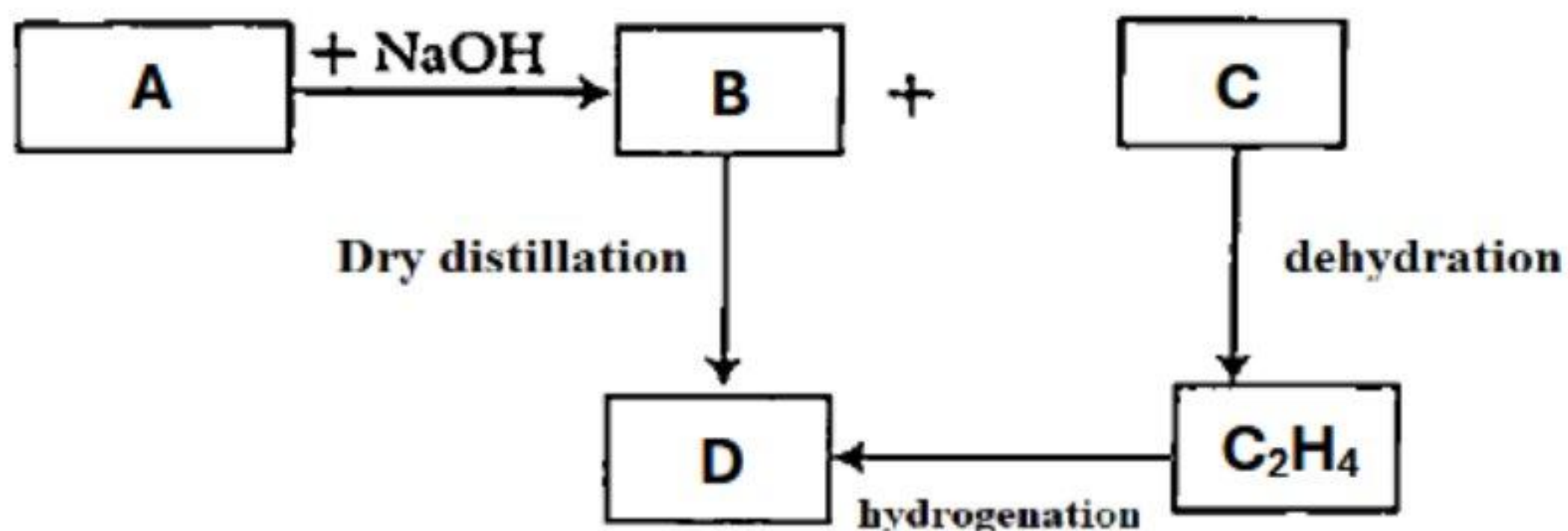

- Which of these compounds?

a) Reacts with metals forming alkoxide:

.....  
 .....

b) Gives by ammonolysis, organic acid amid:

.....  
 .....

c) Hydrocarbon that reacts by substitution:

.....  
 .....

d) The acid of salt (B):

.....  
 .....

46. Choose from the following compounds:



a) Compound has paramagnetic properties.

.....  
 .....

b) A compound of a non-transition element

.....  
 .....

c) A compound of transition element whose cation's oxidation state matches its group number

.....  
 .....

d) A compound of transition element has one oxidation state

.....  
 .....

## expermental exam 2025- model (4)

➤ First: choose the correct answer:

1. It is not possible to distinguish between carbonate ions and bicarbonate ions using solution (X), but they can be distinguished using solution (Y).

Which of the following Solutions are (X, Y)?

Choice	X	Y
(A)	Hydrochloric acid	Magnesium sulfate
(B)	Barium chloride	Ammonium hydroxide
(C)	Silver nitrate	Lead acetate
(D)	Calcium hydroxide	Sulfuric acid

2. Which of the following solid salts releases a gas and deposits an element when diluted hydrochloric acid is added to it?

- a)  $\text{Na}_2\text{CO}_3$
- b)  $\text{Na}_2\text{S}_2\text{O}_3$
- c)  $\text{Na}_2\text{SO}_3$
- d)  $\text{Na}_2\text{S}$

3. When sodium sulfite solution is added to silver nitrate solution, followed by heating the reaction products, which of the following is correct about the precipitate?

- a) Remains without changing after heating.
- b) A white precipitate is formed first, followed by a black precipitate.
- c) A black precipitate is formed first, followed by a white precipitate.
- d) A black precipitate turns white by heating.

4. In adding silver nitrate solution to two salt solutions separately, a yellow precipitate forms in both cases. One dissolves in concentrated ammonium hydroxide, while the other does not. The salts, in order, are:

- a) Sodium phosphate, sodium iodide
- b) Sodium phosphate, sodium bromide
- c) Sodium chloride, sodium iodide
- d) Sodium chloride, sodium bromide

5. In the reaction:



Which of the following is correct?

- a) The reaction is complete, and the reaction rate increases with the increase in the surface area of the reactants.
  - b) The reaction is complete, and the reaction rate decreases with heating.
  - c) The reaction is reversible, and the reaction rate increases with the increase in the surface area of the reactants.
  - d) The reaction is reversible, and the reaction rate decreases with heating.
6. Alloys are very important in industry. Iron alloys are produced through:
- a) Blast furnace followed by Midrex furnace.
  - b) Midrex furnace followed by open-hearth furnace.
  - c) Open-hearth furnace followed by electric furnace.
  - d) Electric furnace followed by blast furnace.
7. The correct order of chemical processes used to convert an alkane with (5 ) atoms into an aliphatic insect side with (18 ) atoms is:
- a) Strong heating with rapid cooling, then halogenation, then polymerization
  - b) Strong heating with rapid cooling, then polymerization, then halogenation
  - c) Polymerization, then halogenation, then strong heating with rapid cooling
  - d) Halogenation, then strong heating with rapid cooling, then polymerization

8. In the reaction:

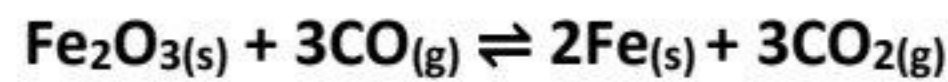

The equilibrium constant is:

- (A)  $K_c = \frac{[\text{CO}_2]^3}{[\text{CO}]^3}$
- (B)  $K_c = \frac{2[\text{CO}_2]^3}{3[\text{CO}]}$
- (C)  $K_c = \frac{[\text{Fe}]^2 \times [\text{CO}_2]^2}{[\text{CO}]^3}$
- (D)  $K_c = \frac{[\text{Fe}]^2 \times [\text{CO}_2]^2}{[\text{Fe}_2\text{O}_3][\text{CO}]^3}$

9. Three elements from the first transition series are [X, Y, Z], where:

- Element (X) has an oxidation state greater than its group number.
- Element (Y) is the most chemically active element in the series.
- Element (Z) is a non-transition element. Which of the following is incorrect?
  - a) Element (X) does not react with dilute acids.
  - b) Element (Z) is used to protect metals from corrosion.
  - c) Element (Y) react with water.
  - d) One alloy of element (X) is used in heating coils.

10. Two elements (X, Y) from the first transition series:

- Element (X) has four unpaired electrons in the (d) sublevel and can easily oxidize from  $X^{2+}$  to  $X^{3+}$ .
- Element (Y) has five unpaired electrons in the (d) sublevel and can easily reduce from  $Y^{+3}$  to  $Y^{+2}$ .
- The alloy composed of the two elements is used in:
  - a) Heating coils
  - b) Railway tracks
  - c) Soft drink cans
  - d) Dry cell batteries

11. Two consecutive elements (X, Y) from the first transition series are characterized by a half-filled (3d) sublevel. The elements are:

Choice	X	Y
(A)	Copper	Zinc
(B)	Manganese	Iron
(C)	Chromium	Manganese
(D)	Vanadium	Chromium

12. During the extraction of iron from its ores, impurities are removed using chemical and physical methods. The correct order of these methods is:

- Magnetic separation, roasting
- Roasting, surface tension
- Electrical separation, crushing
- reduction, sintering

13. Chloride and iodide ions in their solutions can be detected using solution (X), form two precipitates and one only of the two precipitates dissolves in solution (Y). Which of the following is correct for solutions (X, Y)?

Choice	X	Y
(A)	Barium nitrate	Lead acetate
(B)	Concentrated sulfuric acid	Ammonia solution
(C)	Hydrochloric acid	Magnesium sulfate
(D)	Silver nitrate	Ammonium hydroxide

14. in purifying a copper rod containing impurities of platinum, magnesium, iron, and gold, which of the following exits in the solution?

- [Cu<sup>2+</sup>, Au<sup>3+</sup>, Pt<sup>2+</sup>]
- [Cu<sup>2+</sup>, Fe<sup>3+</sup>, Mg<sup>2+</sup>]
- [Cu, Au, Pt]
- [Cu, Fe, Mg]

15. Fuel cells and mercury cells are important primary cells.

Which of the following the similarity between a fuel cell and a mercury cell ?

- a) The need storing energy.
- b) They require an external fuel supply.
- c) Their electromotive force (EMF).
- d) The electrolyte in both cells.

16. Study the following aliphatic organic compounds and then answer:

(A)	(B)	(C)	(D)
$C_6H_{14}O_6$	$C_3H_8O_3$	$C_2H_6O_2$	$C_3H_8O$

Which of the following is correct?

- a) Compound (A) is lower boiling point than (C) and (B).
- b) Compound (B) is higher boiling point than (D) and (C).
- c) Compound (C) is lower boiling point than (D) and (A).
- d) Compound (D) is higher boiling point than (B) and (A).

17. Which of the following compounds is an example of an aliphatic acid amide?

- a)  $CH_3NH_2$
- b)  $C_6H_5CONH_2$
- c)  $(CH_3)_2NH$
- d)  $CH_3CONH_2$

18. When connecting the terminals of a lead-acid battery to an external DC source with a slightly higher voltage than its EMF, Which of the following is correct?

- a) It transforms from a galvanic cell into an electrolytic cell, and the pH increases.
- b) It transforms from an electrolytic cell into a galvanic cell, and the pH increases.
- c) It transforms from an electrolytic cell into a galvanic cell, and the pH decreases.
- d) It transforms from a galvanic cell into an electrolytic cell, and the pH decreases.

19. In the electrolytic cell used to plate a copper medal with a layer of gold, all the following steps and processes are correct except:

- a) Connecting the medal to the negative pole of the DC power source.
- b) The concentration of gold ions in the solution gradually decreases due to reduction.
- c) Gold acts as a reducing agent, while gold ions act as an oxidizing agent.
- d) The loss in the mass of gold equals the gain in the mass of the medal.

20. In the following reaction:

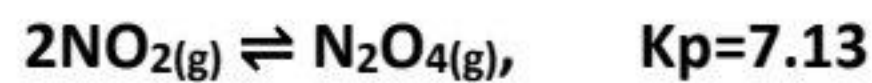

At equilibrium, the partial pressure of  $\text{NO}_2$  in the container is (0.15) atm. the partial pressure of  $\text{N}_2\text{O}_4$  (in atm) is:

- a) [0.16 atm]
- b) [1.0795 atm]
- c) [47.533 atm]
- d) [7.28 atm]

21. When adding drops of potassium hydroxide solution to pure water: Which of the following is correct?

- a) The concentration of hydrogen ions increases, and  $K_w$  increases.
- b) The value of pOH increases, and  $K_w$  remains constant.
- c) The concentration of hydroxide ions increases, and  $K_w$  increases.
- d) The value of pH increases, and  $K_w$  remains constant.

22. Study the following organic compounds:

A	B	C
$C_7H_6O_2$	$C_8H_6O_4$	$C_7H_6O_3$

Which of the following is correct?

- a) Compound (A): one of its salts is used as a preservative; Compound (B): used in the production of Dacron fabric.
- b) Compound (A): used in the production of Bakelite plastics; Compound (C): used in the production of pharmaceuticals.
- c) Compound (B): used in the production of industrial detergents; Compound (C): used in the production of pharmaceuticals.
- d) Compound (C): used in the production of Marookh oil; Compound (B): used in the production of explosives.

23. Which of the following chemical processes are required to obtain TNT from natural gas?

- a) Strong heating and rapid cooling → alkylation → trimerization → nitration
- b) Strong heating and rapid cooling → trimerization → alkylation → nitration
- c) Trimerization → Strong heating and rapid cooling → alkylation → nitration
- d) Trimerization → alkylation → Strong heating and rapid cooling → nitration

24. Based on the following data:

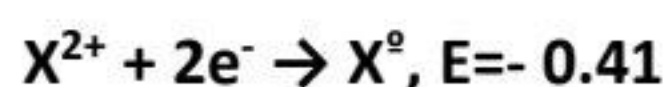

- Which of the following represents the reaction:  $X + Y^{2+} \rightarrow X^{2+} + Y$
- a) Non-spontaneous, and the mass of electrode (X) decreases.
  - b) Non-spontaneous, and the mass of electrode (Y) decreases.
  - c) Spontaneous, and the mass of electrode (X) decreases.
  - d) Spontaneous, and the mass of electrode (Y) decreases.

25. The dry distillation of the organic compound  $[\text{CH}_3\text{CH}(\text{OH})\text{CH}_2\text{COONa}]$  in the presence of soda lime produces:

- [2-Propanol]
- [Propane]
- [2-Butanol]
- [Butane]

26. The table below shows the reduction potentials of some metals:

Al	Ag	Zn	Cu	Fe
- 1.67 V	0.8 V	- 0.76 V	0.34 V	- 0.41 V

When equal masses of iron are placed in equal-concentration solutions of aluminum nitrate, silver nitrate, zinc nitrate, and copper(II) nitrate:

Which of the following is correct about the corrosion of iron in these solutions?

- Slower in zinc nitrate than in aluminum nitrate.
- Slower in copper nitrate than in silver nitrate.
- Slower in silver nitrate than in copper nitrate.
- Slower in aluminum nitrate than in zinc nitrate.

27. From the following series of reactions, identify compound (C):

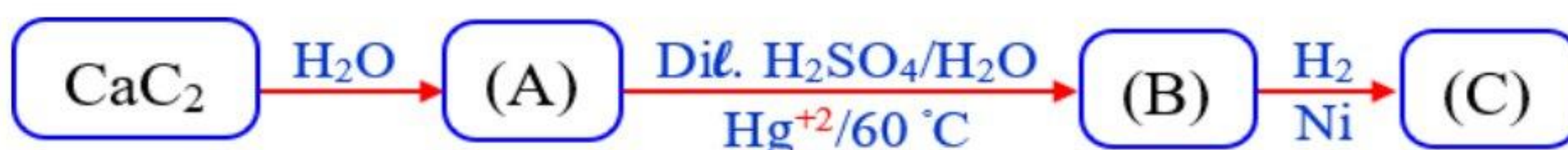

- $\text{CH}_2\text{CHOH}$
- $\text{C}_2\text{H}_5\text{OH}$
- $\text{CH}_3\text{CHO}$
- $\text{CH}_3\text{OH}$

28. Name the following compound according to IUPAC rules:

- 5,5,5 tri methyl octane
- 2-ethyl-3,3-dimethylheptane
- ethyl -5-5- di-methyl 1-heptene
- 3,4,4-trimethyl-1-octene

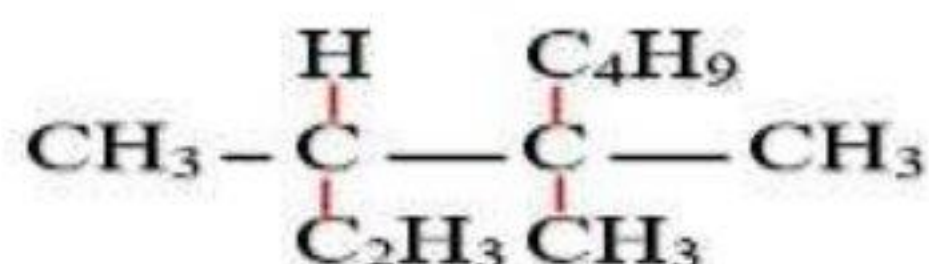

29. Which of the following pairs of compounds are not isomers?

- a) ethanol, dimethyl ether
- b) Methyl acetate, propanoic acid
- c) Methyl propanoate, propyl ethanoate
- d) Pentene, Cyclopentane

30. An excess of hydrochloric acid is added to three separated hydrocarbon compounds, (A), (B), and (C).

The results were:

- Compound (A) gives 2,2-dichloropropane.
- Compound (B) gave 2-chloropropane.
- Compound (C) did not react.

Which of the following the correct three compounds?

	(A)	(B)	(C)
(A)	Propene	Propyne	Propane
(B)	Propyne	Propane	Propene
(C)	Propene	Propane	Propyne
(D)	Propyne	Propene	Propane

31. Study the following equations and answer:

- $\text{CH}_3\text{COOH}_{(\text{aq})} \rightleftharpoons \text{CH}_3\text{COO}^-_{(\text{aq})} + \text{H}^+_{(\text{aq})}$
- $\text{HCl}_{(\text{aq})} \rightarrow \text{H}^+_{(\text{aq})} + \text{Cl}^-_{(\text{aq})}$
- $\text{HNO}_{2(\text{aq})} \rightleftharpoons \text{H}^+_{(\text{aq})} + \text{NO}^{2-}_{(\text{aq})}$
- $\text{H}_2\text{CO}_{3(\text{aq})} \rightleftharpoons 2\text{H}^+_{(\text{aq})} + \text{CO}_3^{2-}_{(\text{aq})}$

Which of the following represents the equations involving chemical equilibrium?

- a) Equations [1, 2, 3, 4]
- b) Equations [1, 3, 4]
- c) Equations [1, 2, 4]
- d) Equations [2, 3, 4]

32. The table below represents the molecular formulas of three organic compounds:

A	B	C
$C_3H_4$	$C_3H_6$	$C_3H_8$

Which of the following is correct?

- a) Compound (A) is unsaturated and used in the manufacture of hoses and wire insulation.
- b) Compound (B) is unsaturated and used for lining cooking utensils.
- c) Compound (C) is unsaturated and a component of LPG gas.
- d) Compound (B) is unsaturated and used in the manufacture of carpets.

33. One of the ester formulas is  $CH_3CH_2CH_2CH_2OOCCH_2CH_3$ . What acid and alcohol were used to prepare this ester?

	Acid	Alcohol
(A)	Butanoic acid	Butanol
(B)	Butanoic acid	Propanol
(C)	Propanoic acid	Butanol
(D)	Propanoic acid	Propanol

34. Iron(III) oxide can be obtained by strong heating the following compounds in the absence of air except:

- a) Iron (II) sulfate
- b) Iron(II) oxalate
- c) Iron (III) hydroxide
- d) Hydrated iron(III) oxide

35. The boiling points of the following compounds are given below. The compounds have similar molar masses. Which of the following correctly expresses their boiling points?

	$C_4H_9OH$	$CH_3COOC_2H_5$	$C_3H_7COOH$
(A)	77.1 °C	163.5 °C	117.7 °C
(B)	117.7 °C	77.1 °C	163.5 °C
(C)	163.5 °C	77.1 °C	117.7 °C
(D)	117.7 °C	163.5 °C	77.1 °C

36. To obtain a highly explosive organic compound from sodium heptanoate, the following chemical processes are performed in sequence after dry distillation:

- Friedel-Crafts reaction → Catalytic reforming → Nitration.
- Catalytic reforming → Friedel-Crafts reaction → Nitration.
- Nitration → Catalytic reforming → Friedel-Crafts reaction
- Catalytic reforming → Nitration → Friedel-Crafts reaction.

37. The following chemical formulas represent three carboxylic acids:

(X)	(Y)	(Z)
$C_7H_6O_2$	$C_2H_4O_2$	$C_7H_6O_3$

Which of the following is correct?

- Acid (Z) is stronger than acid (Y), and both react with 2 mol of NaOH.
- Acid (X) is stronger than acid (Y), and both react with 1 mol of NaOH.
- Acid (X) is stronger than acid (Z), and both react with 2 mol of NaOH.
- Acid (Y) is stronger than acid (X), and both react with 1 mol of NaOH.

38. In adding drops of HCl to the following equilibrium reaction:

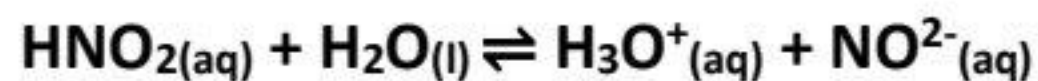

Which of the following statements is correct?

- a) The equilibrium constant for nitrous acid changes, and the dissociation of nitrous acid decreases.
- b) The equilibrium constant for nitrous acid remains unchanged, and the dissociation of nitrous acid decreases.
- c) The equilibrium constant for nitrous acid changes, and the pH of the solution decreases.
- d) The equilibrium constant for nitrous acid remains unchanged, and the pOH of the solution decreases.

39. When 10 mL of HCl (0.5 M) is added to neutralize (0.5 g) of sodium chloride and sodium carbonate, the mass of chloride in the mixture is:

[Given: Na = 23, Cl = 35.5, C = 12, O = 16]

- a) 0.0025 g
- b) 0.265 g
- c) 0.1426 g
- d) 0.235 g

40. Which steps are correct to obtain iron(III) hydroxide from iron(II) oxalate?

- a) Heat in the absence of air → Add HCl → Expose the product to air → Add NH<sub>4</sub>OH.
- b) Heat in air → Reduce at 500 °C → Add dilute H<sub>2</sub>SO<sub>4</sub> → Add NH<sub>4</sub>OH.
- c) Heat in air → Reduce at 250 °C → Add concentrated H<sub>2</sub>SO<sub>4</sub> → Add NH<sub>4</sub>OH.
- d) Heat in air → Reduce at 800 °C → passing chlorine gas → Add NH<sub>4</sub>OH.

41. To obtain an aliphatic compound used as an insecticide from calcium carbide, the following chemical processes are performed in sequence after dropping water:

- a) Hydrogenation → Reduction.
- b) Hydrogenation → Oxidation.
- c) Polymerization → Addition halogenation.
- d) Polymerization → Substitution halogenation.

42. The following compounds are hydrocarbon derivatives:

- [X]: Acidic compound and reacts with bromine water. [Y]: Oxidizable compound and soluble in water.
- [Z]: Compound with the same number of carbon atoms as [Y], but has a higher boiling point.

Which of the following matches the compounds?

	[X]	[Y]	[Z]
(A)	Carboxylic acid	Phenol	Primary alcohol
(B)	Alcohol	Carboxylic acid	Phenol
(C)	Phenol	Monohydric alcohol	Dihydric alcohol
(D)	Phenol	Tertiary alcohol	Dihydric alcohol

43. Study the following electrochemical cells:

- $X + Y^+ \rightarrow X^+ + Y$  (emf = 1.1 V)
- $Z + W^+ \rightarrow Z^+ + W$  (emf = 1.5 V)

When similar electrodes from cells (1) and (2) are connected in parallel, which of the following statements is correct?

- Cell (1) is galvanic, and cell (2) is electrolytic; electrode X is the anode.
- Cell (2) is galvanic, and cell (1) is electrolytic; electrode Z is the anode.
- Cell (1) is galvanic, and cell (2) is electrolytic; electrode W is the cathode.
- Cell (2) is galvanic, and cell (1) is electrolytic; electrode Y is the cathode.

44. The correct IUPAC name for [ 2-bromo-3-ethyl-4-hexyne] is:

- 5-bromo-4-ethyl-2-heptyne
- 6-bromo-2-methyl-2-hexyne
- 2-bromo-5-methyl-4-heptyne
- 2-bromo-5-methyl-4-pentyne

➤ **Second: answer the following essay questions:**

45. In the electrolytic cell used to extract aluminum from bauxite, determine the quantity of electricity in Faradays required for the release of a gaseous mixture containing one mole of carbon monoxide and carbon dioxide with writing the chemical equations.

.....  
.....  
.....  
.....

46. Study the following diagram and answer the questions:

Given that X, Y, and Z are organic compounds.

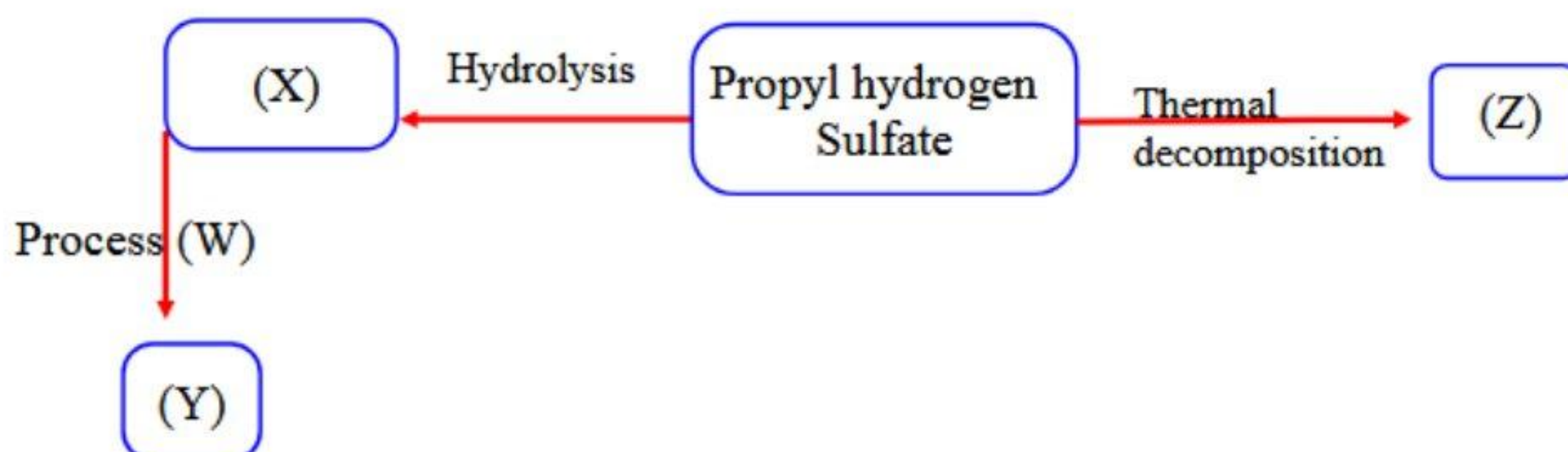

a) Deduce the IUPAC name of the compound formed by adding HCl to compound (Z).

.....  
.....  
.....

b) Write the structural formula of the compound formed by the catalytic hydration of compound (Z).

.....  
.....

c) Identify the name of process (W), given that compound (Y) does not give effervesce with sodium carbonate.

.....  
.....

d) Write the structural formula of compound (Y).

.....  
.....

## experimental exam 2025- model (5)

➤ First: choose the correct answer:

1. A transition metal X, when mixed with iron at a high temperature, forms a mixture harder than steel. The compound  $XO_2$  is used in:
  - a) In dry batteries / As a catalyst in oxygen gas preparation.
  - b) Sunscreen products / As a catalyst in  $H_2O_2$  decomposition.
  - c) Pigments / As a catalyst in iron production.
  - d) Fungicides / manufacturing Space craft.

2. From the following reactions:

- $TiO_2 \rightarrow Ti_2O_3$
- $MnO_2 \rightarrow MnO$

Which of the following is correct?

- a) Oxidation of the transition element in the first reaction.
  - b) Oxidation of the transition element in the second reaction.
  - c) A less stable compound forms in the first reaction.
  - d) A less stable compound forms in the second reaction.
3. The ratio of unpaired electrons in element (A), which acts as a catalyst in ammonia production, to those in element (B), which acts as a catalyst in oil hydrogenation, is:

Choice	Element A	Element B
a	2	1
b	1	2
c	3	1
d	1	3



4. Two elements (A) and (B). Element (A) is paramagnetic in its atomic state and has only one oxidation state. One of the oxides of element (B),  $B_2O_5$ , is used in manufacture of dyes . The elements (A) and (B) are:
- A: Scandium - B: Vanadium.
  - A: Scandium - B: Manganese.
  - A: Manganese - B: Zinc.
  - A: Vanadium - B: Zinc
5. The correct sequence of processes, to extract iron from iron (III) salt is:
- Thermal decomposition - Reduction - Reaction with an alkali.
  - Reduction - Reaction with an alkali - Thermal decomposition.
  - Reaction with an alkali - Thermal decomposition - Reduction.
  - Thermal decomposition - Reaction with an alkali - Reduction.
6. Which of the following cations precipitates carbonate ions ( $CO_3^{2-}$ ) from its solution?
- $K^+$
  - $Na^+$
  - $Ca^{2+}$
  - $NH_4^+$
7. Which of the following compounds doesn't dissolve in hydrochloric acid?
- $BaSO_4$
  - $Fe(OH)_2$
  - $MgCO_3$
  - $Al(OH)_3$

8. In adding dilute hydrochloric acid to three solid salts (A, B, C) separately:

- Gas evolved in case (A).
- Gas evolved and a precipitate is formed in case (B).
- No reaction occurs in case (C).

The ions (A, B, C) present in the salts are:

- a) A:  $\text{NO}_3^-$ , B:  $\text{S}_2\text{O}_3^{2-}$ , C:  $\text{SO}_4^{2-}$   
b) A:  $\text{NO}_3^-$ , B:  $\text{S}^{2-}$ , C:  $\text{PO}_4^{3-}$   
c) A:  $\text{CO}_3^{2-}$ , B:  $\text{S}_2\text{O}_3^{2-}$ , C:  $\text{SO}_4^{2-}$   
d) A:  $\text{CO}_3^{2-}$ , B:  $\text{NO}_3^-$ , C:  $\text{PO}_4^{3-}$

9. Which of the following can be used to distinguish between Hydrochloric acid and sulfuric acid solutions ?

- a) Ammonia solution.  
b) Sodium carbonate.  
c) Sodium nitrite.  
d) Sodium sulfide.

10. Which of the following two solutions can decolorize  $\text{KMnO}_4$  in acidic medium?

- a)  $\text{FeSO}_4$  and  $\text{NaNO}_2$   
b)  $\text{FeSO}_4$  and  $\text{NaNO}_3$   
c)  $\text{Fe}_2(\text{SO}_4)_3$  and  $\text{KNO}_2$   
d)  $\text{Fe}_2(\text{SO}_4)_3$  and  $\text{NaNO}_3$

11. For the following reaction:  $\text{Mg}_{(s)} + 2\text{HCl}_{(aq)} \rightarrow \text{MgCl}_{2(aq)} + \text{H}_{2(g)}$

Which of the following is correct about the reaction type?

- a) It is complete in both open and closed systems.  
b) It is complete in an open system and reversible in a closed system.  
c) It is reversible in an open system and complete in a closed system.  
d) It is reversible in both open and closed systems.

12. If the  $K_c$  of reversible reaction equals 60, if the reactant concentrations are doubled at the same temperature. Which of the following is a correct value of  $K_c$ ?

- a) 3600
- b) 120
- c) 60
- d) 0.017

13. Which of the following describes a role of catalysts?

- a) Increases the concentration of products at equilibrium.
- b) Changes the equilibrium constant of a chemical reaction.
- c) Reduces the time needed to reach equilibrium.
- d) Increases the activation energy.

14. If the ionization constant of HCN is  $K_a=4.9 \times 10^{-10}$ , which of the following is the value of pH for the solution of concentration 0.1M ?

- a) 5.154
- b) 10.31
- c)  $2 \times 10^5$
- d)  $2 \times 10^6$

15. Which of the following is correct during the operation of the fuel cell?

- a) The stored chemical energy is changed into electrical energy.
- b) Hydrogen ions move toward the electrolytic solution.
- c) Reduction of hydrogen.
- d) Oxidation of oxygen.

16. In a secondary battery with the following electrodes:



To charge the battery, it must be connected to a source with an electromotive force equals:

- a) 1.20 V
- b) 1.17 V
- c) 1.16 V
- d) 1.12 V

17. Which is correct for the anodic protection of iron?

- a) Connect iron to a metal with a higher reduction potential.
- b) Iron acts as the anode in an electrolytic cell.
- c) Iron acts as the anode in a galvanic cell.
- d) Connect iron to a metal with a higher oxidation potential.

18. Passing 0.5 A for 30 minutes through a solution of a divalent element deposits 0.2612 g of the element. The atomic mass of the element is:

- a) 14
- b) 28
- c) 56
- d) 84

19. A galvanic cell consists of ( Ni and Pb ) electrodes. Which of the following describes what happens in this cell?

Choice	Change in Lead Mass	Change in Nickel Ion Concentration
a	Increases	Decreases
b	Increases	Increases
c	Decreases	Decreases
d	Decreases	Increases

20. The diagram shows an experiment to coat a metal spoon with copper. If the experiment does not work, which of the following modification is required to work?

- Add more copper(II) sulfate.
- Increase the temperature of the electrolyte.
- Replace the copper electrode with a graphite electrode.
- Reverse the battery connections.

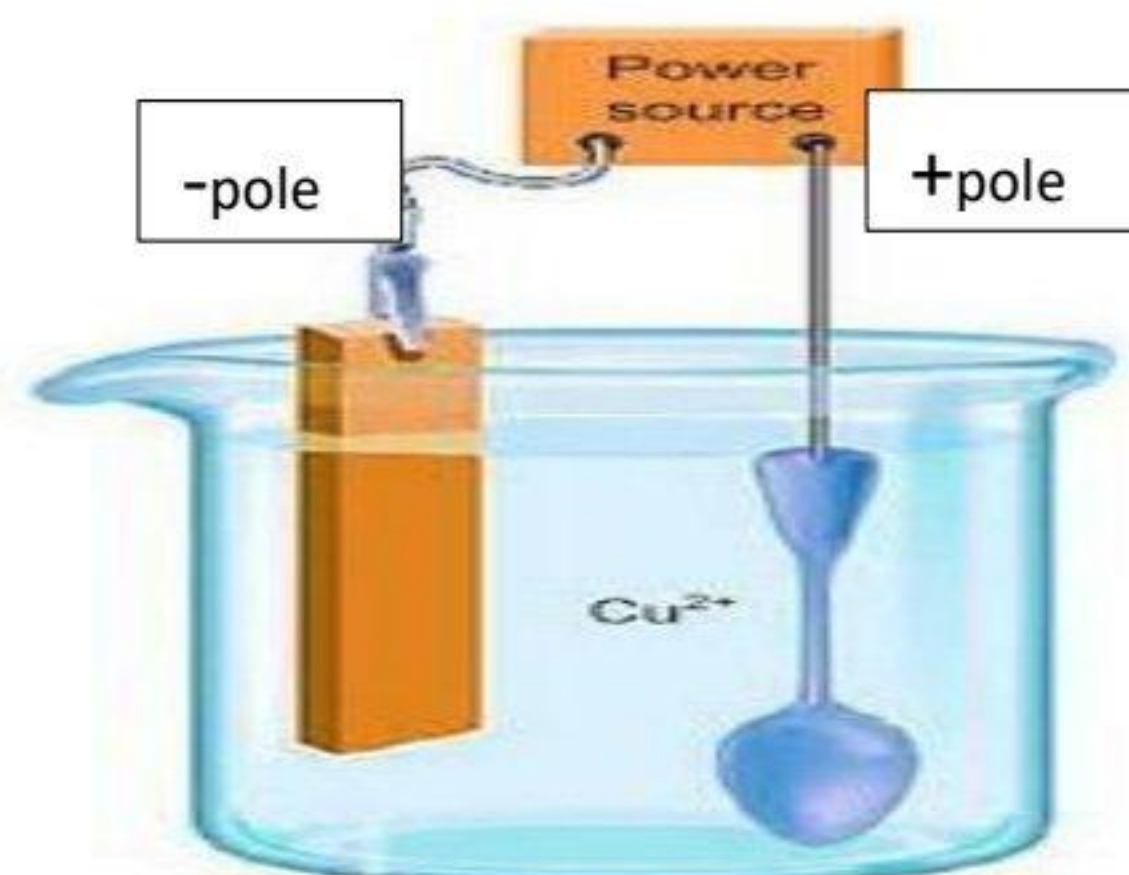

21. The amount of electricity in Faraday needed to obtain one mole of aluminum from molten

$\text{Al}_2\text{O}_3$  is:

- 1F
- 2F
- 3F
- 6F

22. Which of the following compounds does not undergo ammonolysis process?

- $\text{CH}_3\text{COOC}_6\text{H}_5$
- $\text{CH}_3\text{COOH}$
- $\text{CH}_3\text{COOCH}_3$
- $\text{CH}_3\text{COOC}_2\text{H}_5$

23. What is the IUPAC name for the compound shown?

- 2-Bromo-5-Chloropentane
- 1-Chloro-4-Bromopentane
- 4-Bromo-1-Chloropentane
- 5-Chloro-2-Bromopentane



24. Which of the following is true about thermal catalytic cracking of octane?

- It produces two non-isomeric compounds.
- It produces only saturated compounds.
- It produces only unsaturated compounds.
- It gives the same products as fractional distillation.

25. The number of methyl groups in the molecule of 1-Phenyl-1-Propene is:

- a) 3
- b) 1
- c) 2
- d) 0

26. Which of the following is the monomer used to prepare the corresponding polymer?

- a) 1-Methyl-1-Propene
- b) 2-Methyl-1-Propene
- c) 2-Methyl-1-Butene
- d) 1-Methyl-1-Butene

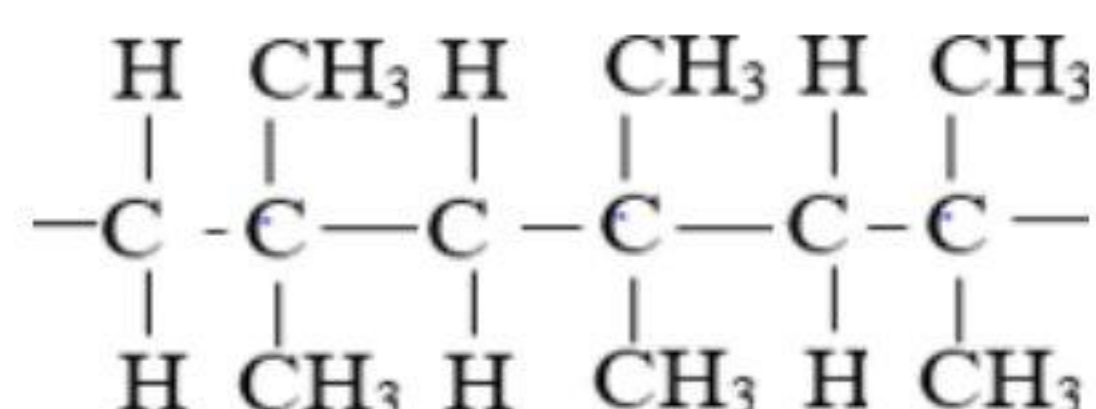

27. Markonikoff's rule can't be applied to:

- a) Propene.
- b) 2-Methyl-2-Butene.
- c) 3,2-Dimethyl-2-Butene.
- d) Vinyl Bromide.

28. In catalytic reforming of normal heptane followed by hydrogenation, Which of the following is the obtained product?

- a) Toluene.
- b) Ethyl Benzene.
- c) Ethyl cyclohexane.
- d) Methyl Cyclohexane.

29. The basic hydrolysis of the compound  $\text{C}_3\text{H}_7\text{Br}$ , gives :

- a) Only primary alcohol.
- b) Only secondary alcohol.
- c) Primary or tertiary alcohol.
- d) Primary or secondary alcohol.

30. Which of the following are not isomers?

- a) Naphthalene and Diphenyl.
- b) 2-Phenylpropane and 1-Ethyl-2-Methylbenzene.
- c) 1-Chloro, 2-Phenylethane and 1-Chloro-3,2-Dimethylbenzene.
- d) Cyclohexane and 1,1-Dimethyl Cyclobutane.

31. Two derivatives of hydrocarbons (A and B) having some chemical properties.

(A) is used in cosmetic skin products, and (B) is used to treat heart attacks.

The compounds (A and B) are:

- a) A: Ethanol acid, B: Aspirin.
- b) A: Phenol, B: Picric acid.
- c) A: Glycerol, B: Dacron.
- d) A: Salicylic acid, B: Trinitroglycerin.

32. A super saturated solution of  $\text{BaF}_2$  contains  $[\text{Ba}^{2+}]$  of  $(1.82 \times 10^{-2})$ ,  $[\text{F}^-] = 3.64 \times 10^{-2}$

Which of the following is the solubility product  $K_{sp}$  of the salt?

- a)  $2.41 \times 10^{-5}$
- b)  $24.1 \times 10^{-5}$
- c)  $66.2 \times 10^{-5}$
- d)  $6.62 \times 10^{-5}$

33. Heating Iron (III) Hydroxide in air, followed by reaction with hot concentrated  $\text{H}_2\text{SO}_4$

Which of the following is the predicted products?

- a) Iron(II) sulfate and hydrogen gas.
- b) Iron(II) sulfate and water.
- c) Iron(III) sulfate and hydrogen gas.
- d) Iron(III) sulfate and water.

34. The relation ( $2M_bV_b=3M_aV_a$ ) is used for titration of:
- Hydrochloric acid with sodium hydroxide.
  - Phosphoric acid with barium hydroxide.
  - Sulfuric acid with barium hydroxide.
  - Phosphoric acid with sodium hydroxide.
35. A (4g) alloy of iron and copper is placed in dilute HCl, producing 1.12L of  $H_2$  gas. Which of the following is volume of gas would be produced when the same alloy is placed in concentrated nitric acid? (Cu = 63.5, Fe = 56)
- 22.4L
  - 11.2L
  - 0.847L
  - 1.12L
36. Two elements (X) (Y) of the first transition series. Element (X) is in the 9<sup>th</sup> Column of the periodic table, while (Y) is in the 9<sup>th</sup> . Column in d-block.  
Which of the following statement is correct?
- The density of (X) is higher than (Y).
  - Both elements have only one oxidation state.
  - Both elements have four sublevels in the +2 state.
  - Both are paramagnetic in the +3 state
37. 100 ml of water contains 2 g of Silver Sulfate. If the solubility product of the salt is  $1.0976 \times 10^{-5}$  (Molar mass = 310g), which of the following is correct?
- The ionization degree of the salt is  $2.8 \times 10^{-2}$ .
  - The concentration of  $Ag^+$  is  $1.4 \times 10^{-2}$ .
  - The mass of dissolved salt is  $43.4 \times 10^{-2}$  g.
  - The concentration of sulfate ions is  $2.8 \times 10^{-2}$ .

38. For the reaction:  $A_{2(g)} + B_{2(g)} \rightleftharpoons 2AB_{(g)} + \text{heat}$

The value of equilibrium constant  $K_c$  increases when:

- a) The temperature is decreased.
- b) The concentration of  $A_2$  is increased.
- c) The concentration of  $B_2$  is decreased.
- d) The temperature is increased.

39. An aqueous solution with (pH=7.4) Which of the following is the  $[OH^-]$ ?

- a)  $2.51 \times 10^{-7} \text{ M}$
- b) 6.6 M
- c)  $3.9 \times 10^{-8} \text{ M}$
- d) 4.7 M

40. Which of the following is the alcohol that can be oxidized to yield the shown compound?

- a) 2-Butanol
- b) 3-Methyl-1-Butanol
- c) 3-Butanol
- d) 2-Methyl-1-Butanol

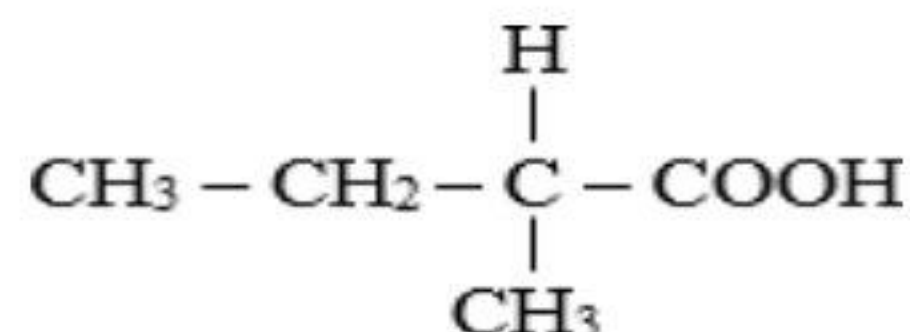

41. According to the diagram:

Both compounds (X) and (Y) are:

- a) React only by addition.
- b) Aromatic compounds.
- c) React only by substitution.
- d) Cyclic hydrocarbons.

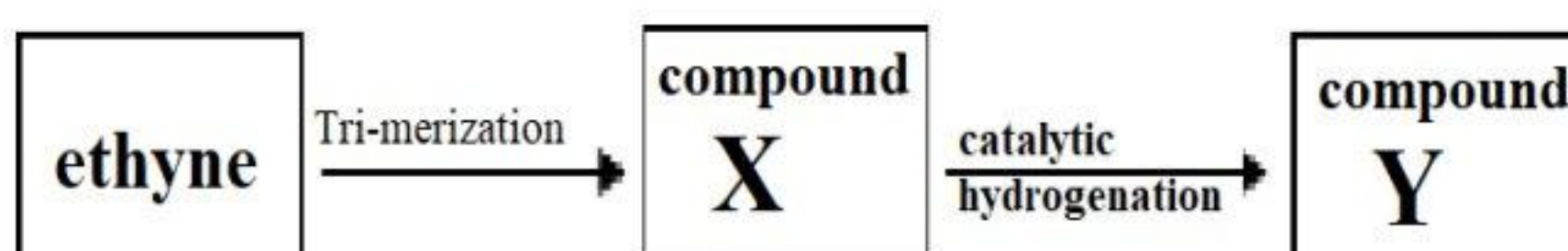

42. ( A ) and( B ) are hydrocarbons with open chains, where A contains( 3 ) carbon atoms and (B) Contains (6) carbon atoms. (B) is chemically more reactive than (A). The hydrocarbons A and B are:

	A	B
A	Alkane (gaseous)	Alkene (liquid)
B	Alkane (liquid)	Alkene (liquid)
C	Alkane (gaseous)	Alkene (gaseous)
D	Alkane (liquid)	Alkene (gaseous)

43. Which of the following the number of hydrogen moles required to convert (1) mole of  $[\text{CH}_3\text{CCCH}_2\text{COOH}]$  compound into a compound with no( Pi bonds) ?

- a) 2
- b) 3
- c) 4
- d) 5

44. Which of the following does not represent the formula  $\text{C}_6\text{H}_{14}$ ?

- a) 2,3-Dimethylbutane
- b) 3-Methylpentane
- c) 2,2-Dimethylpropane
- d) 2,2-Dimethylbutane

➤ **Second: answer the following essay questions:**

45. From the following diagrams:

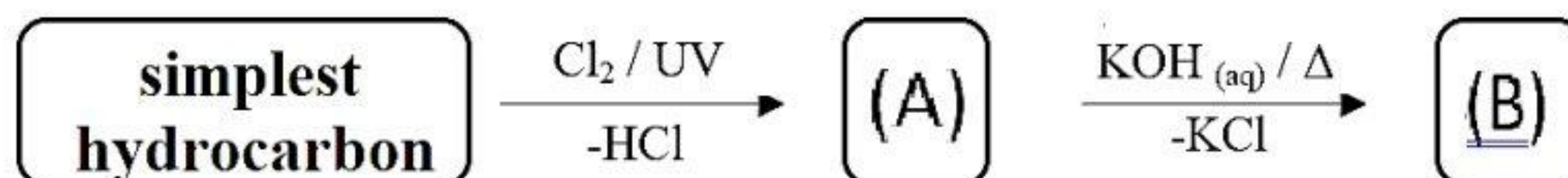

- a) Name the compound formed according to IUPAC when (B) reacts with formic acid, and write its structural formula.

.....

.....

.....

.....

. Name the compound formed according to IUPAC when (A) reacts with benzene in the presence of anhydrous aluminum chloride and write its structural formula.

.....

.....

.....

46. When a quantity of electricity is passed through two connected cells in series, the first contains a solution of  $\text{Pb}(\text{NO}_3)_2$ , depositing 8.28 g of lead, while the second undergoes the reaction:  $\text{X}^{4+} + 3\text{e}^- \rightarrow \text{X}^+$  (Pb ==207)

Calculate the number of moles of the substance  $\text{X}^+$  formed.

.....

.....

.....

## expermental exam 2025- model (6)

➤ First: choose the correct answer:

1. By studying the corresponding table, the correct order of the elements (Z, Y and X) in order of density:

- a)  $X > Y > Z$
- b)  $Z > Y > X$
- c)  $Y > X > Z$
- d)  $X > Z > Y$

Electronic structure	Ion Symbol
(Ar), $3d^2$	$X^{+2}$
(Ar), $3d^4$	$Y^{+3}$
(Ar), $3d^5$	$Z^{+3}$

2. Which of the following does not occur when siderite and limonite are roasted?

- a) Red ore, easily reduced is produced
- b) The iron percentage in the ore increases
- c) C) Impurities are oxidized into solid substances
- d) d) The ore is dried from moisture

3. Three transition elements (Z, Y and X) are located at the end of the 3d series and form the compounds  $ZB_2$ ,  $YB_2$ ,  $XB_2$ , if (X) is the largest in atomic number, the correct order of their ions according to the magnetic moment:

- a)  $Z^{+2} > Y^{+2} > X^{+2}$
- b)  $X^{+2} > Y^{+2} > Z^{+2}$
- c)  $Z^{+2} > X^{+2} > Y^{+2}$
- d)  $X^{+2} > Z^{+2} > Y^{+2}$

4. The correct order to obtain iron (II) sulphide from siderite is

- a) reduction/oxidation/heating/reaction with sulphur
- b) heating/oxidation/reduction/reaction with sulphur
- c) Reaction with sulphur/oxidation/reduction/heating
- d) Reaction with sulphur/heating/reduction/oxidation



5. From the following diagram:-

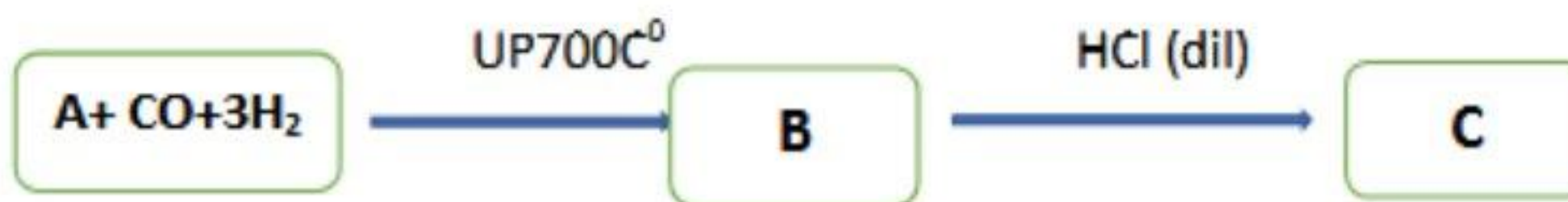

The product(C) is:-

- a)  $\text{FeCl}_2$
- b)  $\text{FeCl}_3$
- c)  $\text{Fe}_2(\text{SO}_4)_3$
- d)  $\text{FeSO}_4$

6. From the following diagram:-

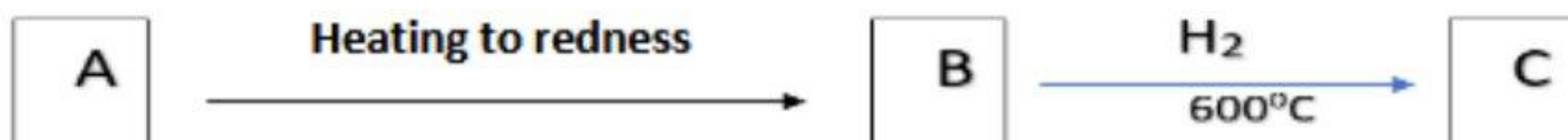

The compounds (A), (B) and (C) are.....

Choice	A	B	C
a)	$\text{Fe}_2\text{O}_3$	$\text{FeO}$	$\text{Fe}_3\text{O}_4$
b)	$\text{Fe}_3\text{O}_4$	$\text{FeO}$	$\text{Fe}_2\text{O}_3$
c)	$\text{Fe}_3\text{O}_4$	$\text{Fe}_2\text{O}_3$	$\text{FeO}$
d)	$\text{Fe}_2\text{O}_3$	$\text{Fe}_3\text{O}_4$	$\text{FeO}$

7. Element (X) is used as a catalyst in the industrial preparation of ammonia gas by the Haber-Bosch method, and element (Y) is used in the manufacture of car tires and printing inks.

When the two elements are chemically combined, the alloy is .....

- a) Duralumin
- b) Stainless steel
- c) Cementite
- d) Steel iron

8. Silver cation is precipitated with each of the following except:
- $\text{HCl}_{(aq)}$
  - $\text{Na}_2\text{S}_{(aq)}$
  - $\text{NaI}_{(aq)}$
  - $\text{NaNO}_3_{(aq)}$
9. The gas that decolorizes the acidified potassium permanganate is :
- $\text{CO}_2$  gas and acts as an oxidizing agent
  - $\text{SO}_2$  gas acts as a reducing agent
  - $\text{SO}_3$  gas acts as an oxidizing agent
  - $\text{H}_2\text{S}$  gas acts as a reducing agent
10. 10-A solution of salt (X) is divided into two parts:
- Silver nitrate solution was added to the first part, forming a white precipitate that turns violet when exposed to light
  - To the second part, an ammonium carbonate solution was added, forming a white precipitate that dissolves in water containing  $\text{CO}_2$ .
- Then the salt (X) is:
- Calcium phosphate
  - Lead iodide
  - C) Calcium iodide
  - d) Calcium chloride
11. A mixture of 4 grams of calcium hydroxide and calcium chloride, required 100 ml of 0.5M HCl acid to titrated.
- The percentage of the base in the sample is equals: (Ca=40, 16, H=1)
- 7.5%
  - 46.25%
  - 53.57%
  - 90.55

12. From the following diagram:

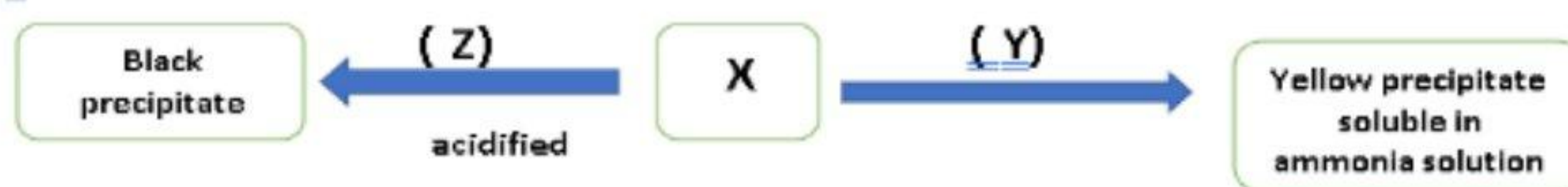

Then the compounds (X), (Y) and (Z) are .....

Choices	X	Y	Z
A	$\text{Cu}_3(\text{PO}_4)_2$	$\text{AgNO}_3$	$\text{H}_2\text{S}$
B	$\text{AgNO}_3$	$\text{Cu}_3(\text{PO}_4)_2$	$\text{NH}_4\text{OH}$
C	$\text{H}_2\text{S}$	$\text{Na}_2\text{SO}_4$	$\text{CuS}$
d	$\text{CuS}$	$\text{NH}_4\text{OH}$	$\text{HCl}$

13. 200 ml of 2M nitric acid added to 300 ml of 3M of another sample of the same acid . Then the concentration of the produced solution equal:

- a) 6.2M
- b) 1.3M
- c) 2.6M
- d) 3.1M

14. When a brown iodine solution is added to Salt (A), the brown color of iodine disappears and when dilute sulphuric acid is added to another quantity of the same Salt (A) solution, a white precipitate is formed.

- So the salt (A) is .....

- a) Potassium sulphate
- b) Lead (II) thiosulphate
- c) Copper (II) sulphide
- d) Sodium nitrite

15. In the reaction:  $\text{N}_2 (\text{g}) + \text{O}_2 (\text{g}) \rightleftharpoons 2\text{NO} (\text{g}), \Delta H = (+)$

- Which of the following factors increases the concentration of the products?
- a) Lowering the temperature
- b) Increasing the pressure
- c) Adding an amount of oxygen to the reaction
- d) Increasing the volume of the vessel

16. What is the pH value of the solution resulting from mixing 40ml of 0.1M HCl with 10ml of 0.45 M NaOH?

- a) 6
- b) 8
- c) 12
- d) 10

17. In the reaction:

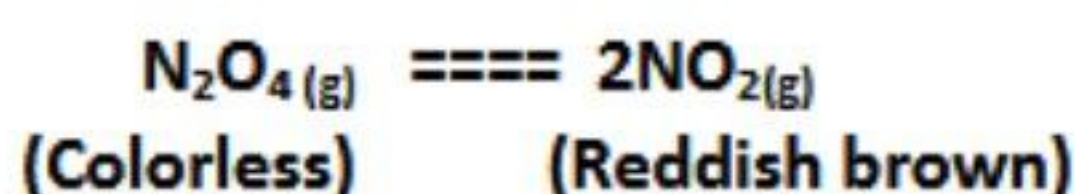

When adding excess of the colorless gas....

- a) The color increases and the Kc value remain constant.
- b) The color increases and the Kc value increases.
- c) The color decreases and the Kc value remain constant.
- d) The color decreases and the Kc value decreases.

18. If you know that the solubility product of silver chloride salt in a saturated 0.1L solution is  $2.56 \times 10^{-6}$ , then the mass of silver chloride dissolved in the solution is: (AgCl = 143.5g/mol)

- a) 0.023 g
- b) 0.0115 g
- c)  $2.3 \times 10^{-6}$  g
- d)  $1.15 \times 10^{-6}$  g

19. In the corresponding equilibrium system:



- The value of the equilibrium constant of this system increases when:
  - a) Adding more carbon dioxide.
  - b) Raising the temperature.
  - c) Decreasing the amount of carbon dioxide.
  - d) Lowering the temperature.

20. Which of the following systems is irreversible?

- a)  $\text{N}_2\text{O}_4(\text{g}) = \text{NO}_2(\text{g})$  (closed vessel)
- b)  $\text{AgBr}(\text{s}) = \text{Ag}^+(\text{aq}) + \text{Br}^-(\text{aq})$  (saturated solution)
- c)  $\text{HCOOH}(\text{aq}) + \text{H}_2\text{O}(\text{l}) = \text{HCOO}^-(\text{aq}) + \text{H}_3\text{O}^+(\text{aq})$
- d)  $\text{Mg}(\text{s}) + \text{H}_2\text{SO}_4(\text{aq}) = \text{MgSO}_4(\text{aq}) + \text{H}_2(\text{g})$

21. In the following equilibrium system:

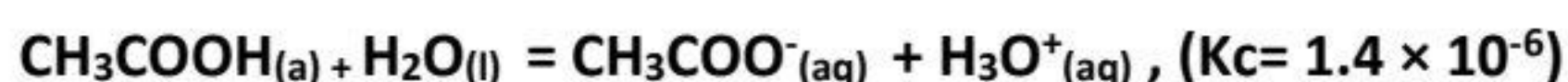

- When drops of  $\text{HNO}_3$  are added to the reaction, the  $\text{K}_a$  value for acetic acid becomes:
  - a)  $1.4 \times 10^{-6}$
  - b)  $2.3 \times 10^{-4}$
  - c)  $0.99 \times 10^{-5}$
  - d)  $2.3 \times 10^{-7}$

22. An electrochemical cell has a reduction potential of its electrodes:



- Which of the following is true?
  - a) The reaction is spontaneous and the emf = +2.72 V
  - b) Spontaneous reaction and emf = +3.21 V
  - c) The reaction is non-spontaneous and the emf = -2.72 V
  - d) Non-spontaneous reaction and emf = -3.21 V

23. The mass of sulfuric acid in (380 cm<sup>3</sup>) of the electrolyte of a fully charged lead- acid battery is

- a) 340g
- b) 494g
- c) 425g
- d) 325g

24. The amount of electricity required to evolve 355 gm of chlorine by electrolysis of molten NaCl compound is: (Cl=35.5)

- a)  $9.25 \times 10^4$  c
- b)  $9.65 \times 10^5$  c
- c)  $9.65 \times 10^5$  c
- d)  $4.83 \times 10^5$  c

25. The quantity of electricity required to convert 1 mol of  $\text{MnO}_4^-$  to 1 mol of  $\text{Mn}^{+2}$  is:

- a) 96500 c
- b)  $3 \times 96500$  c
- c)  $5 \times 96500$  c
- d)  $7 \times 96500$  c

26. Which of the following diagrams shows the change in the mass of a piece of iron to be plated when an electric current is passed through an aqueous solution of gold chloride III using a pure gold anode?

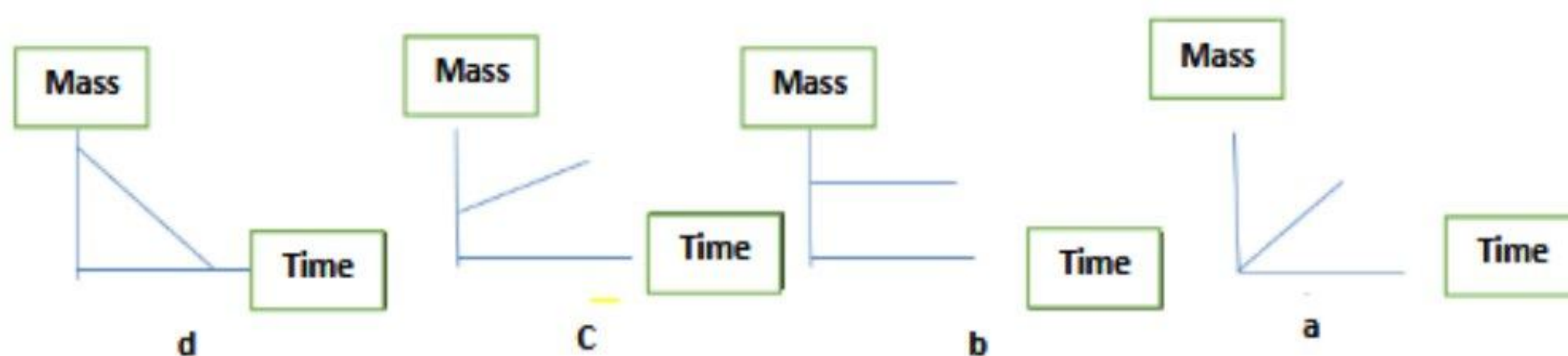

27. The standard reduction potential of X, Y, and Z are as in the table:

Element	Z	Y	X
Reduction potential	-2.023 V	+0.4 V	-0.99 V

- Which of the following plating causes the fastest corrosion of the coated metal when scratched?
  - Plating element Z with element Y
  - Plating element Y with element X
  - Plating element Y with element Z
  - Plating Element X with Element Z

28. The following reactions occur at the electrodes of a galvanic cell:

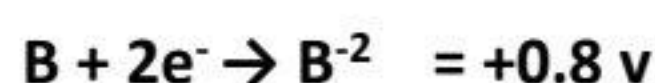

- The electrical potential required to convert this cell to electrolytic cell into an electrolytic cell equals:
  - 8 V
  - 1.2V
  - 2.5 V
  - 0.4 V

29. When a strip of the zinc is placed in a silver nitrate solution, the following reaction occurs:



- Which of the following correctly describes what happened?
  - Oxidation of zinc and reduction of silver ions
  - Reduction of the zinc and reduction of silver ions
  - Oxidation of zinc and oxidation of silver
  - Reduction of zinc and oxidation of silver

30. What is the product of halogenation of halothane with one mole of bromine?
- 1, 2-dibromo-2, 2, 2-trifluoro-1-chloroethane
  - 1, 1-dibromo-1-chloro-2, 2, 2-trifluoro ethane
  - 1, 2-dibromo-1,2-difluoroethane
  - 1, 1, 1 - trifluoro-2-chloro-1,2-bromoethane
31. When adding 2 moles of hydrogen and then 1 mole of chlorine respectively to one mole of the compound  $\text{CH}_2=\text{CH}-\text{C}\equiv\text{CH}$ , we get:
- 1, 1-dichlorobutane
  - 1, 2-dichlorobutane
  - 1, 3-dichlorobutane
  - 2, 3-dichlorobutane
32. Which of the following process is suitable to obtain 3-methyl- sulfonic- benzene acid from benzene?
- Alkylation t followed by sulfonation
  - Sulfonation followed by alkylation
  - Halogenation followed by sulfonation
  - Sulfonation followed by halogenation
33. Which of the following compounds is produced from oxidation of the Corresponding compound?  $\text{CH}_3 - \text{CH}(\text{CH}_3) - \text{CH}(\text{CH}_3) - \text{CHO}$
- 2, 3-dimethyl propanoic acid
  - 2, 3-dimethyl Butanoic acid
  - 2, 2-dimethyl Butanoic acid
  - 3, 3-dimethyl Butanoic acid

34. The aromatic compound with the molecular formula  $C_7H_8$  can be obtained by which of the following process?

- a) Catalytic reforming of normal hexane
- b) Dry distillation of ethyl benzoate
- c) Catalytic reforming of normal heptane
- d) Dry distillation of methyl benzoate

35. When the simplest branched alkyne combines with ethyl group, the name of the compound becomes.....

- a) 3-Methyl-1-hexyne
- b) 2-methyl-1-pentyne
- c) 1-methyl-1-hexyne
- d) 3-methyl-1-pentyne

36. Four organic compounds (A, B, C and D)

- Compound A reacts with sodium carbonate and sodium hydroxide
- Compound B reacts with sodium and does not react with NaOH
- Compound C oxidizes to A
- Compound D reacts with NaOH and does not react with HCl So the four compounds are:

Choices	A	B	C	D
A	Acid	Alcohol	Aldehyde	Phenol
B	Aldehyde	Phenol	Acid	Alcohol
C	Phenol	Acid	Ether	Ketone
d	Acid	Ketone	Phenol	Ether

37. Alkaline hydrolysis of the isomer of ethyl pentanoate produces all the following except.

- a) Sodium ethanoate
- b) Butanol
- c) Sodium pentanoate
- d) Ethanol

38. Which of the following processes can be used to obtain the simplest aromatic hydrocarbon from an aromatic compound with the formula  $C_nH_nO_3$ ?
- Oxidation by hydrogen peroxide oxidation
  - Reduced by 2 moles of zinc
  - Reduced by 3 moles of zinc
  - Oxidation by potassium permanganate
39. The correct IUPAC name of a compound 2-bromo-5-ethyl-4-hexene is :
- 2-Bromo-5-ethyl-4-pentene
  - 6-bromo-2-ethyl-2-hexene
  - 6-bromo-3-methyl-3-heptene
  - 2-bromo-5-methyl-4-heptene
40. Which of the following compounds gives  $CH_3 - CBr_2 - CH_3$ :
- Mole of bromine to propene.
  - HBr to propene.
  - Mole of bromine to propyne.
  - Mole of HBr to 2-bromopropene.
41. The catalytic hydration of ethyne produces compound (A), which is oxidized to compound (B), and the compound (B) is reduced in the presence of  $CuCrO_4$  to compound (C).
- So the compounds (A), (C) respectively are:
    - Propanal and ethanol.
    - Ethanoic acid and ethanal.
    - Ethanal and ethanol.
    - Propanol and ethanoic acid.

42. Upon hydrolysis of primary alkyl halide, compound (A) is formed. And by hydrolysis of secondary alkyl halides, compound (B) is formed

- So the compound (A) and (B) are:

- a) A: 2-butanol , B: isobutyl alcohol  
 b) A: 1-butanol , B: 2-methyl-2-butanol  
 c) A: 2-methyl-2-propanol , B: 1-butanol  
 d) A: 2-methyl-1-propanol , B: 2-butanol

43. Which of the following compounds is produced from nitration of the corresponding compound?

- a) Ortho – nitro carboxyl benzene  
 b) Meta-nitro benzaldehyde  
 c) Meta-nitro carboxyl benzene  
 d) Para-nitro benzanal

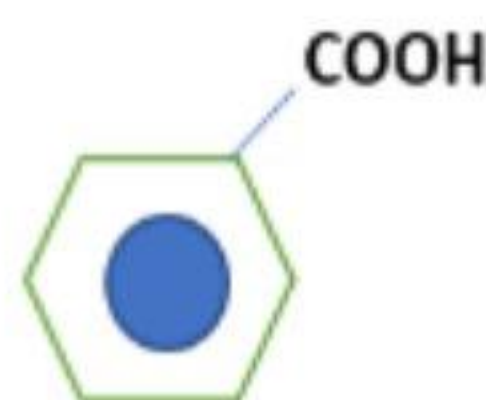

44. You have the following compounds:

- (X) has a higher boiling point than the corresponding hydrocarbon.
- (Y) used in the preparation of a compound used in the treatment of heart disease.
- (Z) is a starting material for the preparation of Marookh oil.
- The compounds (X, Y and Z) are:

Choices	X	Y	Z
A	Methyl acetate	Copper oxide	Ethanol
B	Benzoic acid	Anhydrous copper sulphate	Toluene
C	Formic acid	Terephthalic acid	Benzene
d	Ethanoic acid	glycerol	Salicylic acid

➤ **Second: answer the following essay questions:**

45. In the next reaction:  $\text{H}_2\text{O}_{(v)} + \text{CO}_{(g)} \rightleftharpoons \text{H}_{2(g)} + \text{CO}_{2(g)} + \text{heat}$

Explain the effect of the following factors:

a) Using the catalyst on the carbon dioxide concentration

.....  
.....

b) Increasing the pressure on the concentration of carbon monoxide

.....  
.....

c) Increasing the temperature on the value of the equilibrium constant.

.....  
.....

d) The effect of adding a mixture of (2 moles of hydrogen gas and 3 moles of carbon monoxide gas)

.....  
.....

46. (A, B, C, D) four functional groups for four organic compounds:



( D )

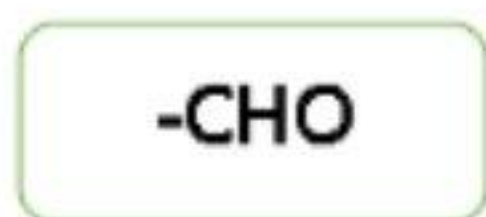

( C )



( B )

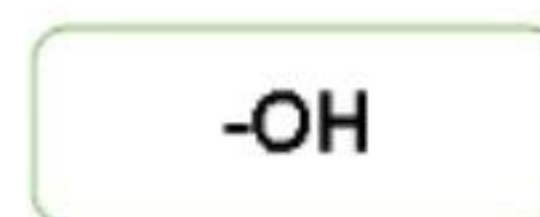

( A )

a) What is the name of group (D), and what is the reason behind this name?

.....  
.....

b) To convert a compound belong to group D into a compound containing group A, a process ..... is required?

.....  
.....

c) Comparing compounds from group (A) to compounds from group (B), which has a higher boiling point?

.....  
.....

d) Write the functional group of the compound resulting from the reaction of a group (A) compound with a group (D) compound?

.....  
.....

## expermental exam 2025- model (7)

➤ First: choose the correct answer:

1. Transition metal (X) has only one oxidation state, So the chemical formula for element (X) chloride is :
  - a) XCl
  - b) XCl<sub>2</sub>
  - c) XCl<sub>3</sub>
  - d) XCl<sub>4</sub>
2. Transition element (X), the chemical formula of its oxide is (XO) and the ion (X) in the oxide contains 24 electrons, so metal (X) can be used in:
  - a) Leather tanning.
  - b) Reinforced Concrete.
  - c) Metal painting.
  - d) Dental implants.
3. All of the following elements can form diamagnetic substances except:
  - a) Titanium
  - b) Chromium
  - c) Manganese
  - d) Iron
4. The number of moles of yellowish grey ore required to produce 1 mole of iron in the blast furnace is equal to:
  - a) 0.5
  - b) 1
  - c) 2
  - d) 3



5. To obtain a reddish brown compound from yellow iron ore, the processes to be performed are respectively:

- Roasting - reduction at 600 OC - addition of dilute sulphuric acid - heating.
- Cracking - addition of dilute sulphuric acid - oxidation - addition of an alkaline solution.
- Roasting - reduction at 800 OC - heating and passing chlorine gas - addition of alkaline solution.
- Cracking - roasting - addition of concentrated sulphuric acid - reduction.

6. In the following diagram (A), (B) are iron compounds:

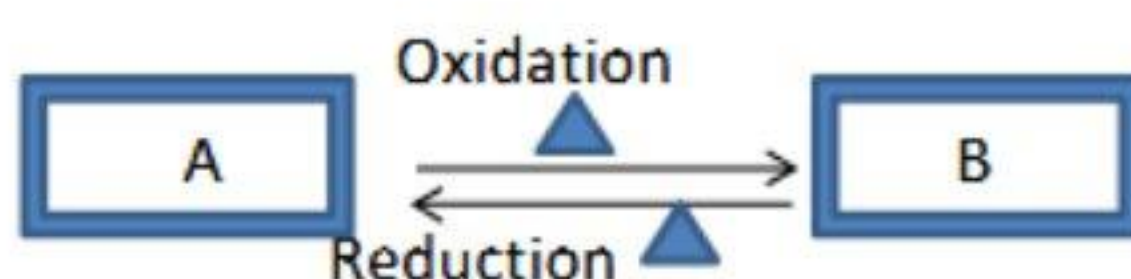

- Which of the following choices express the two compounds (A), (B)?

Choices	A	B
A	Strong magnet	Easily oxidized in air
B	Mixed oxide	Soluble in water
C	Red in color	Black in color
d	React with conc. H <sub>2</sub> SO <sub>4</sub>	Non-oxidisable

7. A transition element of the first main transition series has the electronic structure  $nS^2,(n-1)^{n+4}$

- Which of the following processes cant be used for?
- Detection and treatment of tumors.
  - Manufacture of heating coils and electric furnaces.
  - Rust and acid resistant alloys.
  - Hydrogenation of oils as a catalyst.

8. Two elements A and B of the first main transition series have abnormal electron configuration, which of the following statements does not describe both elements?

- They have the same atomic diameter, so a substitutional alloy can be made of the two elements.
- They have the same number of single electrons in the last main energy level.
- They resist the influence of atmospheric oxygen.
- They have two incomplete main energy levels.

9. Three consecutive transition elements in the first transition series (Z, Y, X), element X, is used in manufacture of rechargeable batteries. Which of the following is the electronic structure of the ions of these elements in the following oxides?



Choices	ZO	Y <sub>2</sub> O <sub>3</sub>	XO <sub>2</sub>
A	3d <sup>6</sup>	3d <sup>6</sup>	3d <sup>6</sup>
B	3d <sup>8</sup>	3d <sup>6</sup>	3d <sup>8</sup>
C	3d <sup>6</sup>	3d <sup>8</sup>	3d <sup>6</sup>
D	3d <sup>6</sup>	3d <sup>8</sup>	3d <sup>8</sup>

10. You have the following pairs of salts:

- (1) Sodium phosphate - sodium iodide.
- (2) Potassium carbonate - lead bicarbonate.
- (3) Sodium nitrite - potassium bromide.
- (4) Potassium sulfate - sodium phosphate.

- Which of these pairs can dilute hydrochloric acid used to differentiate between them separately?

Choices	(1)	(2)	(3)	(4)
A	X	✓	X	✓
B	X	✓	✓	X
C	✓	X	✓	✓
d	X	X	✓	X

11. Which solution does not form a black precipitate when H<sub>2</sub>S gas is passed through it?

- a) CuSO<sub>4</sub>
- b) AgNO<sub>3</sub>
- c) NaCl
- d) Pb(HCO<sub>3</sub>)<sub>2</sub>

12. When lead II acetate solution is added to each anion separately, a black precipitate is formed with (A) and a white precipitate is formed with (B). Which of the following represents the anions (A) and (B)?

Choices	B	A
A	$S^{-2}$	$SO_4^{-2}$
B	$SO_3^{-2}$	$S_2O_3^{-2}$
C	$SO_4^{-2}$	$S^{-2}$
d	$S_2O_3^{-2}$	$SO_3^{-2}$

13. Which of the following salts will form a white precipitate with a solution of silver nitrate and dilute sulfuric acid?

- a) NaCl
- b)  $CaCl_2$
- c)  $Ca(NO_3)_2$
- d) Fe

14. A hydrated sample of calcium chloride,  $CaCl_2 \cdot 2H_2O$  of unknown mass is heated until its mass becomes constant and by collecting the volatile water it was found to have a mass of 1.08 g, so the mass of the sample is equal to: [Ca = 40, Cl = 35.5, H = 1, O = 16]

- a) 1.11 g
- b) 2.21 g
- c) 3.33g
- d) 4.41g

15. 2 g of an impure calcium carbonate sample reacts with  $H_2SO_4$ , releasing 0.224 L of carbon dioxide gas under standard conditions. The percentage of calcium carbonate in

- a) 40%
- b) 50%
- c) 60%
- d) 70%

16. When a halogenated acid (A) is added to a sodium salt, a solution (B) and a gas (C) are formed only, which of the following statements is true?

- a) White precipitate is formed by passing gas (C) in  $(\text{CH}_3\text{COO})_2\text{Pb}_{(\text{aq})}$ .
- b) Black precipitate is formed by adding  $\text{AgNO}_3_{(\text{aq})}$  to solution B.
- c) A black precipitate is formed by passing gas (C) over  $\text{CuSO}_4_{(\text{aq})}$  acidified with (A).
- d) A white precipitate is formed by passing gas (C) over  $\text{AgNO}_3_{(\text{aq})}$

17. Hydrogen gas is industrially prepared from the following reaction under certain conditions: -

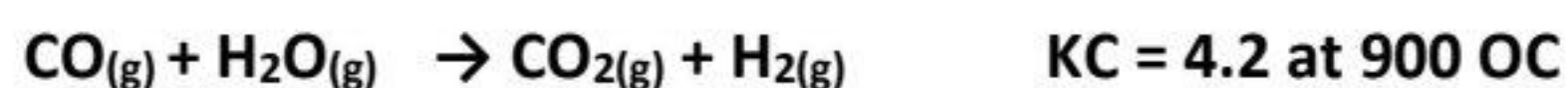

- If 2 mol of CO gas is mixed with 2 mol of water vapour in a 0.5 L vessel
- Which of the following is correct at equilibrium state?

Choices	[ CO ]	[ H <sub>2</sub> O ]	[ CO <sub>2</sub> ]	[ H <sub>2</sub> ]
A	2.69	2.69	1.31	1.31
B	1.31	1.31	2.69	2.69
C	1.31	1.31	1.31	1.31
d	2.69	2.69	2.69	2.69

18. The following table shows the concentrations of substances at equilibrium at different temperatures for the following reaction:  $2\text{NO} + \text{O}_2 \rightleftharpoons 2\text{NO}_2$

	[NO]	[O <sub>2</sub> ]	[NO <sub>2</sub> ]
10 °C	2X M	X M	2X M
20 °C	3X M	2X M	X M

- Which of the following is incorrect?
- a) The reaction is exothermic
- b) The decomposition of NO<sub>2</sub> gas is endothermic
- c) By increasing the temperature, the concentration of the reddish brown Color decreases
- d) By decreasing the temperature, the concentration of [O<sub>2</sub>] and [NO] Increases

19. In the following reaction:  $N_2O_4 \rightleftharpoons 2NO_2 - \text{Heat}$

- What is the effect of increasing both temperature and pressure on the equilibrium position?

Choices	Increasing pressure	Increasing temperature
A	Shift left	Shift left
B	Shift right	Shift left
C	Shift left	Shift right
D	Shift right	Shift right

20. The opposite diagram shows the concentration of the hydronium ion in two solutions of the same volume of two (A, B) completely ionized acids – what are the two acids?

Choices	(A)	(B)
A	HCl	HClO <sub>4</sub>
B	HBr	H <sub>2</sub> SO <sub>4</sub>
C	H <sub>2</sub> SO <sub>4</sub>	HBr
d	HClO <sub>4</sub>	HCl

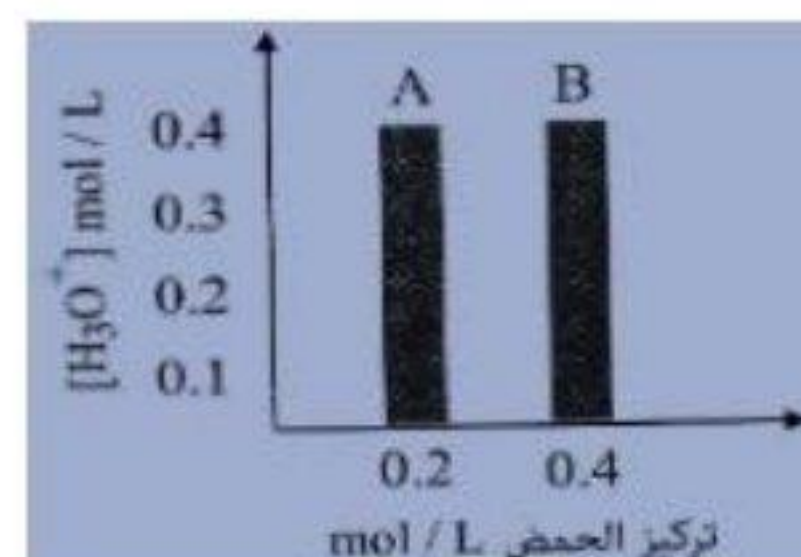

21. When 10 mL of water is added to a 0.1 M caustic soda solution, which of the following is correct?

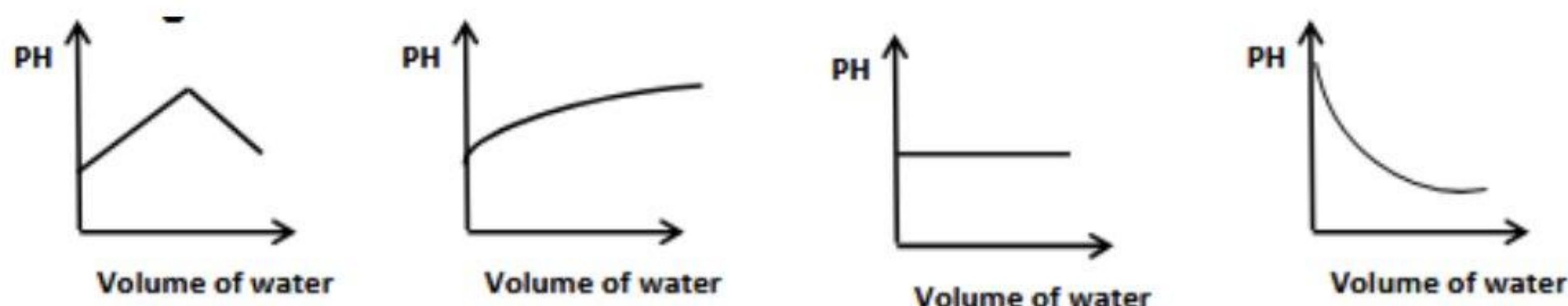

22. The solubility degree of the barium phosphate salt  $Ba_3(PO_4)_2$  in its saturated solution at a given temperature is .....

- $\frac{[PO_4^{-3}]}{2}$
- $\frac{[Ba^{+2}]}{2}$
- $\sqrt{\frac{[PO_4^{-3}]}{2}}$
- $\sqrt[3]{[Ba^{+2}]}$

23. If the reduction potential of aluminium is -1.67 V and the oxidation potential of platinum is -1.2

v. which of the following reactions can occur?

- a)  $\text{Al}^{+3} + \text{Pt} \rightarrow \text{Al} + \text{Pt}^{+2}$   
 b)  $\text{Al} + \text{Pt}^{+2} \rightarrow \text{Al}^{+3} + \text{Pt}$   
 c)  $2 \text{Al}^{+3} + 3 \text{Pt}^{+2} \rightarrow 2 \text{Al} + 3 \text{Pt}$   
 d)  $2 \text{Al} + 3 \text{Pt}^{+2} \rightarrow 2 \text{Al}^{+3} + 3 \text{Pt}$

24. The following table represents the reduction potentials of different elements.

- Which of these elements can be used as a sacrificial pole for the other elements?

Element	A	B	C	D
Reduction potential	-1.02	-2.37	+1.2	-0.12

- a) D for B  
 b) A for C  
 c) D for A  
 d) C for D

25. When  $\text{AgNO}_3$  solution is electrolyzed, which of the following statements is true?

- a)  $\text{Ag}^+$  ions are reduced and hydrogen gas is released at the cathode.  
 b)  $\text{OH}^-$  ions are oxidized and an acidic solution is produced.  
 c)  $\text{NO}_3^-$  ions are oxidized and silver is deposited on the cathode.  
 d) Reduction of  $\text{H}^+$  ions occurs and a basic solution is produced.

26. When plating a metal medallion using a pure silver rod immersed in a solution of silver nitrate, which of the following statements is true?

Choices	Mass of anode	Cathode reaction
A	Increases	$\text{Ag}^+ + \text{e}^- \rightarrow \text{Ag}$
B	unchanged	$\text{NO}_3^- \rightarrow \text{N}_2 + 3\text{O}_2$
C	Decreases	$\text{Ag}^+ + \text{e}^- \rightarrow \text{Ag}$
D	Decreases	$\text{Ag} - \text{e}^- \rightarrow \text{Ag}^+$

27. In the galvanic cell in which the following reaction occurs:

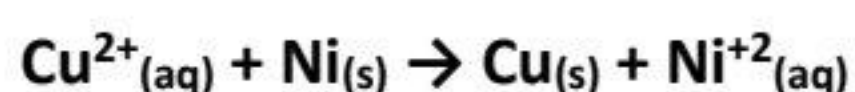

Which of the following is true?

Choices	Anions transfers through salt bridge towards	Electrons transfers through external wire towards
A	Nickel half cell	Nickel half cell
B	copper half cell	Nickel electrode
C	Nickel half cell	copper electrode
d	copper half cell	copper electrode

28. Which of the following is true when forming a galvanic cell from half gold cell and standard hydrogen electrode?

- The pOH value of the solution increases in the hydrogen half-cell.
- The pH value of the solution increases in the hydrogen half-cell.
- The mass of hydrogen on the platinum plate increase.
- The standard hydrogen electrode acts as positive electrode.

29. By studying the oxidation potentials of the following elements, which of the following reactions occur spontaneously?

- $2\text{Na}^+ + \text{Ni} \rightarrow 2\text{Na} + \text{Ni}^{2+}$
- $\text{Pb}^{2+} + \text{Ni} \rightarrow \text{Pb} + \text{Ni}^{2+}$
- $2\text{Cr}^{3+} + 3\text{Ni} \rightarrow 2\text{Cr} + 3\text{Ni}^{2+}$
- $3\text{Na}^+ + \text{Cr} \rightarrow 3\text{Na} + \text{Cr}^{3+}$

	$E_o$
Na	2.71 V
Cr	0.74 V
Ni	0.25 V
Pb	0.13 V

30. The time needed to coat a surface area of  $50 \text{ cm}^2$  with a layer of copper 0.1 cm thick using a current of 2 A is: (copper density =  $8.96 \text{ g/cm}^3$ ) (Cu = 63.5)

- 91.76 min
- 1134.7 min
- 22.19 min
- 67.57 min

31. Upon hydrolysis of monohalo benzene in the presence of an alkaline medium, and then addition of alkanal to the resulting compound in an acidic medium, the resulting organic compound may be used in the manufacture of:

- a) Food preservative.
- b) Explosives.
- c) Ashtrays.
- d) Printing inks.

32. If you know that:

Compound (X): results from the reduction of the simplest aliphatic acid by hydrogen at 200 °C.

Compound Y is an aromatic acid with the molecular formula (C<sub>7</sub>H<sub>6</sub>O<sub>3</sub>).

If compound (X) reacts with compound (Y) under favourable reaction conditions.

Which of the following is correct for the groups contained in the resulting organic compound?

Choices	-COOH	-O-	-COO-	R-
A	X	X	✓	✓
B	✓	✓	✓	<u>X</u>
C	✓	✓	X	✓
d	✓	X	✓	✓

33. The aromatic hydrocarbon that gives an explosive substance by nitration is:

- a) Benzene
- b) Glycerol
- c) Toluene
- d) Phenol

34. Which of the following choices represents the correct order of processes to obtain the simplest aromatic acid from the aromatic compound C<sub>n</sub>H<sub>n</sub>O?

- a) Alkylation - oxidation - nitration.
- b) Reduction - alkylation - oxidation.
- c) Halogenation-reduction-alkylation.
- d) Reduction-halogenation-oxidation.

35. The general formula representing a dichloro cycloalkane compound:

- a)  $C_nH_{2n}Cl$
- b)  $C_nH_{2n}Cl_2$
- c)  $C_nH_{2n+1}Cl$
- d)  $C_nH_{2n-2}Cl_2$

36. What is the molar mass resulting from the Trimerization of the monomer forming the corresponding polymer?

- a) 94.5
- b) 187
- c) 283.5
- d) 374

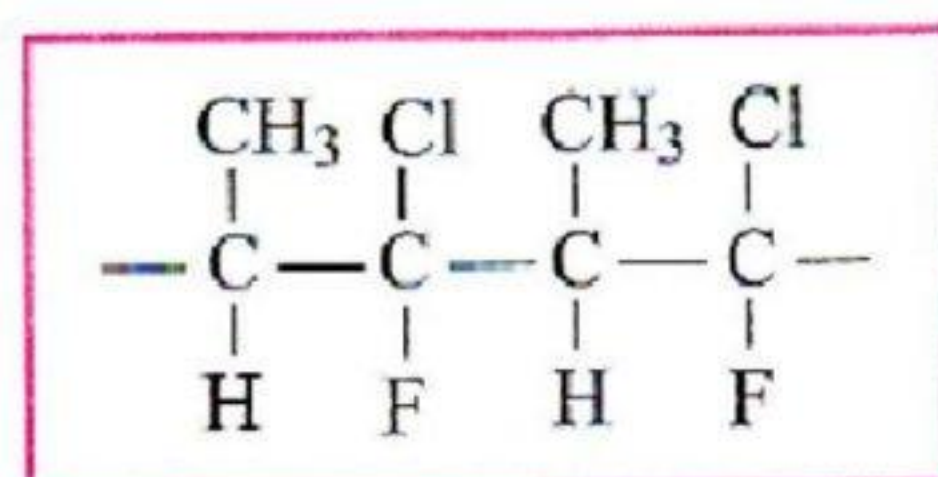

37. What is the molecular formula of unsaturated hydrocarbon, every two moles of it saturated by 4 moles of hydrogen forming saturated hydrocarbon with molecular formula  $C_xH_y$  ?

- a)  $C_xH_{y-2}$
- b)  $C_xH_{y+2}$
- c)  $C_xH_{y-4}$
- d)  $C_xH_{y+4}$

38. One of the following compounds requires 3mol of hydrogen to be saturated.

(biphenyl / 2-phenylpropene / pentene / chlorobenzene)

The name of the resulting compound:

- a) Chloro cyclohexane.
- b) Cyclohexane.
- c) 2-phenylpropane.
- d) Normal pentane.

39. The number of carbon atoms in alkanes, cycloalkanes and alkynes at which isomers begins to appear is:

Choices	Alkynes	Cyclo alkanes	Alkanes
A	3	3	4
B	4	4	4
C	4	3	3
d	3	4	3

40. The ascending order of the following compounds according to the number of sigma bonds ( $\sigma$ ) is:

- Biphenyl < methylbenzene < cyclohexane.
- Methylbenzene < cyclohexane < biphenyl.
- Cyclohexane < biphenyl < methylbenzene.
- Cyclohexane < methylbenzene < biphenyl.

41. Upon hydrolysis in an alkaline medium of two isomers of primary open chain alkyl halide, compounds A and B are formed. Compounds A and B are:

Choices	A	B
A	Isopropyl alcohol	2-butanol
B	2-methyl-2-propanol	1-butanol
C	1-butanol	2-methyl-1-propanol
d	2-butanol	2-methyl-2-propanol

42. Upon adding alkaline potassium permanganate solution to ethylene and then completely oxidized the resulting compound.

The produced compound is:

- One of the glycols compounds.
- A solution with a pH value < 7.
- A dihydroxy acid.
- Monobasic acid.

43. Study the following diagram well, then choose the correct answer:

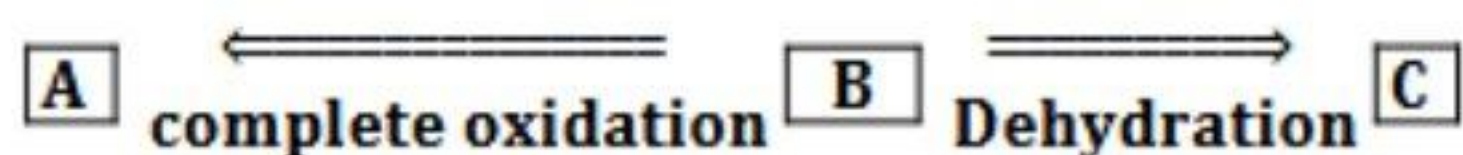

Choices	A	B	C
A	Acid	Alkene	Alcohol
B	Alkene	Alcohol	Acid
C	Acid	Alcohol	Alkene
d	Alcohol	Acid	Alkene

44. When the simplest aliphatic carboxylic compound (A) is reacted with a hydroxyl compound (B), the molar mass of the resulting compound is 74. (C = 12, O = 16, H = 1)

The isomer of compound B is:

- Reacts with sodium metal.
- $\text{CH}_3\text{OCH}_3$
- $\text{C}_2\text{H}_5\text{OH}$
- The boiling point is higher than (A)

➤ **Second: answer the following essay questions:**

45. In the following reaction at equilibrium:  $\text{S}_{(s)} + \text{O}_{2(g)} \rightleftharpoons \text{SO}_{2(g)}$ ,  $K_c = 0.12$

If  $[\text{SO}_2] = 0.2 \text{ M}$  and the volume of the gaseous mixture is 2L.

Calculate the mass of oxygen at equilibrium.

[O = 16]

.....

.....

.....

46. Study the following diagram well, then answer:

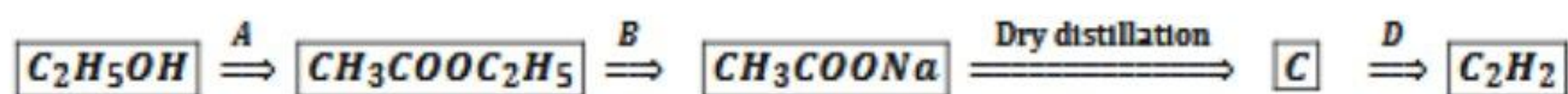

Step (A) is called :	
Step (B) is called:	
Compound (C) is called:	
Conditions of process (D):	

## expermental exam 2025- model (8)

➤ First: choose the correct answer:

- 1.(X& Y ) are two successive elements from first transition elements , if element Y is the last element that can lose all of 4s and 3d electrons ,ionization potential of x that's can break completely filled level of noble gas is .....
  - a) 9<sup>th</sup>
  - b) 7<sup>th</sup>
  - c) 8<sup>th</sup>
  - d) 10<sup>th</sup>
- 2.Which of the following compounds its heating in air is not a redox reaction?.....
  - a) Fe(OH)<sub>3</sub>
  - b) FeCO<sub>3</sub>
  - c) FeSO<sub>4</sub>
  - d) Fe<sub>3</sub>O<sub>4</sub>
- 3.On heating magnetic iron oxide with concentrated hydrochloric acid , water vapor is formed and a mixture of compounds (A) , (B) if the number of moles of compound (B) equals half number of moles of water vapor so which of the following statements is incorrect?
  - a) Compound (A) can be obtained by reaction of iron II oxide with diluted hydrochloric acid.
  - b) Compound (B) can be obtained by reaction of iron III oxide with diluted hydrochloric acid.
  - c) Compound (A) can be obtained by reaction of iron II carbonate with diluted hydrochloric acid.
  - d) Compound (B) can be obtained by passing chlorine gas on red hot iron.



4. Which of the following represents the gradual in hardness?

- a) Iron and manganese alloy is harder than titanium harder than iron.
- b) Iron and magnesium alloy is harder than iron alloy harder than titanium.
- c) Titanium is harder than iron and manganese alloy harder than iron.
- d) Iron is harder than iron and manganese alloy harder than titanium.

5. Which of the following elements have the same magnetic moment of chromium element?

- a)  $^{25}\text{Mn}$
- b)  $^{28}\text{Ni}$
- c)  $^{43}\text{Tc}$
- d)  $^{42}\text{Mo}$

6. You have three alloys with different uses :

- Alloy 1: used in jewelry
- Alloy 2 : used in railway track
- Alloy 3 : used in plating iron handles

These alloys are common in:

- a) Type of alloy
- b) Elements forming it
- c) Consists of same non-metal
- d) More than one correct

7. Which columns of elements are called transition elements in modern periodic table?

- a) 1 to 2
- b) 3 to 10
- c) 3 to 11
- d) 13 to 18

8. In which of the following cases cations can be separated by adding diluted hydrochloric acid?

- a)  $\text{K}^+ / \text{Fe}^{2+}$
- b)  $\text{Pb}^{2+} / \text{Hg}^+$
- c)  $\text{Ba}^{2+} / \text{Ca}^{2+}$
- d)  $\text{Pb}^{2+} / \text{Al}^{3+}$

9. On adding lead II acetate solution to the following salt solutions, a white ppt is formed in all of them, except .....

- a) NaCl
- b) NaBr
- c) Na<sub>2</sub>S
- d) Na<sub>2</sub>SO<sub>4</sub>

10. On adding (NH<sub>4</sub>)<sub>2</sub>CO<sub>3</sub> solutions, which contains .....ions, white ppt is not formed.

- a) Ba<sup>2+</sup>
- b) Ca<sup>2+</sup>
- c) Sr<sup>2+</sup>
- d) K<sup>+</sup>

11. By adding ammonia solution to two silver precipitates, the first, which doesn't, affected by sunlight and doesn't dissolve, but the second which turns into violet by sunlight which of the following may represent the anions respectively?

- a) I<sup>-</sup> / Cl<sup>-</sup>
- b) CO<sub>3</sub><sup>2-</sup> / PO<sub>4</sub><sup>3-</sup>
- c) CO<sub>3</sub><sup>2-</sup> / SO<sub>4</sub><sup>2-</sup>
- d) Cl<sup>-</sup> / I<sup>-</sup>

12. Barium chloride solution reacts with salt solutions contain ions of                      And a white ppt is formed

- a) Ca<sup>2+</sup> / PO<sub>4</sub><sup>3-</sup>
- b) Ag<sup>+</sup> / SO<sub>4</sub><sup>2-</sup>
- c) Pb<sup>2+</sup> / HCO<sub>3</sub><sup>-</sup>
- d) Na<sup>+</sup> / NO<sub>3</sub><sup>-</sup>

13. On adding starch solution to                      solution its color turns into blue

- a) I<sup>-</sup>
- b) I<sub>2</sub>
- c) Br<sup>-</sup>
- d) Br<sub>2</sub>

14. The main reagent of nitrite ion and main reagent of nitrate ion can be differentiated by using all the following except.....
- Sodium chloride
  - Sodium iodide
  - Sodium thiosulphate
  - Barium chloride
15. If you know that 0.25 L from benzoic acid solution contains  $1.6555 \times 10^{20}$  of benzoate ions, what is the PH of the solution?
- 2.69
  - 2.96
  - 3.69
  - 3.93
16. Which of the following is correct for a solution of Barium hydroxide of concentration 0.015 M?
- $\text{pH} = 12.48$
  - $\text{pOH} = 9.42$
  - $[\text{H}_3\text{O}^+] = 3.45 \times 10^{-9} \text{ M}$
  - $[\text{OH}^-] = 0.045 \text{ M}$
17. The isomer of the molecular formula  $\text{C}_4\text{H}_9\text{Br}$  which produces from the by alkaline hydrolysis 2-methyl - 2 - propanol is .....
- $\text{CH}_3(\text{CH}_2)_2\text{CH}_2\text{Br}$
  - $\text{CH}_3\text{CH}(\text{CH}_3)\text{CH}_2\text{Br}$
  - $(\text{CH}_3)_3\text{CBr}$
  - $\text{C}_2\text{H}_5\text{CHBrCH}_3$

18.If the following reaction takes place in the galvanic cell:

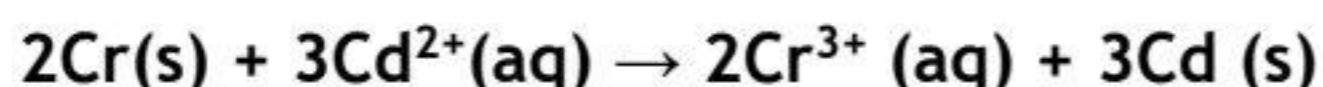

Which one of the following statements is applied to this cell.....

- a) The mass of the chromium electrode increases
- b) Oxidation for ions of chromium electrode takes place
- c) Electrons move from cadmium electrode to chromium
- d) The mass of cadmium electrode increases

19.From the following equations



Which of the following does not happen by immersing a sheet of copper into iron III ions?

- a) Electrons transfer from copper atoms to iron III ions
- b) Concentration of iron III ions decreased
- c) concentration of copper II ions decreased
- d) Mass of copper decreased

20.By passing current in two cells connected in series containing solution of (ZY) & (Wx) the produced mass of Z = 1.5 g & mass of x=2.5g the equivalent mass of Z=.....where the equivalent mass of x=9g

- a) 9 g
- b) 15 g
- c) 5 g
- d) 5.4 g

21. Four metals (W, X, Z & Y) reduction potentials of (W = +1) (X = -3) & oxidation potentials of (Y = +2), (Z = -2)

Which of the following is incorrect?

- a) Metals (X) can be replace both (W) ions and hydrogen ions from their solutions
- b) E.M.F of galvanic cell formed from (X & Y) > (W & Z)
- c) We can store solution contains ions of (X) in vessel made of (Y)
- d) From these metals strongest reducing agent is (X) & strongest oxidizing agent is (Z) ions.

22. If you know that:

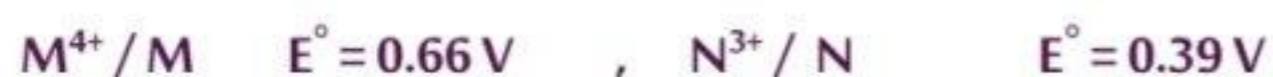

The emf for the cell of the previous reaction equals?

- a) -0.54 V
- b) -0.27 V
- c) +0.27V
- d) +0.54 V

23. Which One of the following is considered a reducing agent?

- a)  $MnO_4^- \rightarrow Mn^{2+}$
- b)  $NO_3^- \rightarrow NO$
- c)  $S \rightarrow S^{2-}$
- d)  $2Cl^- \rightarrow Cl_2$

24. The following ester  $CH_3OOC C_6H_5$  Can be obtained by a reaction of .....

- a) Phenol with methanol
- b) Phenol with acetic acid
- c) Benzoic acid with methanol
- d) Benzoic acid with ethanol

25. Which of the following compounds is an isomer of an open chain hydrocarbon that includes four carbon atoms and two-pi bond?
- Cyclobutane
  - 1- butyne
  - 2- butene
  - Methylpropene
26. Markownikoff's rule is applied when adding halogenic acid to all the following compounds except .....
- propene
  - 1 - butyne
  - 2 - butene
  - Methyl propene
27. What is the alcohol which is difficult to be oxidized by normal oxidizing agents from the following ?
- $\text{CH}_3\text{CH}_2\text{CH}_2\text{CH}_2\text{OH}$
  - $\text{CH}_3\text{CH}_2\text{CH}(\text{OH})\text{CH}_3$
  - $(\text{CH}_3)_2\text{CHCH}_2\text{OH}$
  - $(\text{CH}_3)_3\text{COH}$
28. Which of the following statement is incorrect about urea?
- First organic compound practically can be prepared from inorganic compound
  - Urea molecule includes 7 sigma bonds and one pi bond
  - Urea is used as fertilizers to supply plant with its needs from nitrogen and phosphorus
  - From organic compound which dissolves in water
29. Which of the following formulae represents 5,3 - dimethylhexanal ?
- $\text{CH}_3\text{CH}(\text{CH}_3)\text{CH}_2\text{CH}(\text{CH}_3)\text{CH}_2\text{COOH}$
  - $\text{CH}_3\text{CH}(\text{CH}_3)\text{CH}_2\text{CH}(\text{CH}_3)\text{CHO}$
  - $\text{CH}_3\text{CH}(\text{CH}_3)\text{CH}_2\text{CH}(\text{CH}_3)\text{CH}_2\text{CHO}$
  - $\text{CH}_3\text{CH}(\text{CH}_3)\text{CH}_2(\text{CH}_3)\text{CH}_2\text{CHO}$



30. On detection of abuse drivers to alcoholic drinks

- a) Is oxidized  $\text{Cr}^{3+}$  ion to  $\text{Cr}^{6+}$  ion
- b) Is oxidized  $\text{Cr}^{6+}$  ion to  $\text{Cr}^{3+}$  ion
- c) Is reduced  $\text{Cr}^{6+}$  ion to  $\text{Cr}^{3+}$  ion
- d) Is reduced  $\text{Cr}^{3+}$  ion to  $\text{Cr}^{6+}$  ion

31. To obtain potassium methoxide from methyl iodide

- a) By heating with aqueous solution of potassium hydroxide
- b) By heating with aqueous solution of sodium hydroxide then by reacting the product with potassium hydroxide
- c) By heating with aqueous solution of sodium hydroxide then by reacting the product with potassium
- d) By heating with potassium

32. To obtain 2- pentanone

- a) Oxidation of secondary pentyl alcohol
- b) Oxidation of iso pentyl alcohol
- c) Oxidation tertiary pentyl alcohol
- d) More than one correct

33. Number of isomers of 1 - propanol which doesn't react with Na metal :

- a) 0
- b) 1
- c) 2
- d) 3

34. Which of the following compounds its molecule contains the largest number of oxygen atoms?

- a) Sorbitol
- b) T.N.T
- c) The compound used as antiseptic for the treatment of burns
- d) The produced compound from reaction in nitration condition with 1,2,3 trihydroxy propane

35. In the following reaction :



Which of the following represents ( A ) compounds?

- a) A is Benzamide
- b) A is ethanoic
- c) A is ethylamine
- d) A is benzoic acid

36. What's the volume of 4 mol/L nitric acid needed to produce 200ml of 0.5 mol /L of the same acid ?

- a) 225 ml
- b) 25 ml
- c) 175 m
- d) 40 ml

37. The compound which reacts by substitution and doesn't react by addition is .....

- a)  $\text{C}_6\text{H}_6$
- b)  $\text{CH}_4$
- c)  $\text{C}_2\text{H}_4$
- d)  $\text{C}_2\text{H}_2$

38. Iron III chloride can be obtained from siderite through the following process.....

- a) Thermal decomposition / neutralization with hot conc. HCl acid
- b) Roasting / reduction above 700 c / directly combination with  $\text{Cl}_2$
- c) Thermal decomposition/ reduction above 700 c / directly combination with  $\text{Cl}_2$
- d) More than one is correct

39. The substance when dissolves in water gives electrolytic solution :

- a)  $\text{H}_2$  gas
- b) NaOH
- c) oil
- d) Glucose

40. 1 M hydrochloric acid solution its pOH equals :

- a) 1
- b) 0
- c) 2
- d) 13

41. If you know that third ionization potential of iron metal is 2956 KJ / mol , so the third ionization potential of manganese is .....

- a) 2389 KJ / mol
- b) 2500 KJ / mol
- c) 3250 KJ / mol
- d) 2830 KJ / mol

42. Which of the following elements never has an ion with electronic configuration [ 18Ar ] , 3d5 ?

- a) Mn
- b) Co
- c) Ni
- d) Fe

43. On passing 1 F through copper II chloride solution the amount of evolved chlorine gas equals:

- a) 8.4 L
- b) 33.6 L
- c) 22.4 L
- d) 11.2 L

44. Silver chloride salt and lead II chloride salt can be distinguished without reagents they can be distinguished by:

- a) Solubility in water
- b) Exposure to light
- c) Using concentrated ammonia solution
- d) By heating

➤ **Second: answer the following essay questions:**

**45. write the electron configuration of the silver atom (47Ag) according to principle energy levels.**

.....  
.....  
.....

**46. Write balanced chemical equations and the reaction conditions:  
How can you obtain acetamide from ethene?**

.....  
.....  
.....  
.....

## experimental exam 2025- model (9)

➤ First: choose the correct answer:

1. An element (X) of the first transition series, the M level has twice as many electrons as the L level. Which of the following is true for the element?
  - a) It reacts instantaneously with acids.
  - b) It forms an alloy with chromium that is resistant to low -temperature corrosion.
  - c) It is used with cadmium to make rechargeable batteries.
  - d) A catalyst in obtaining liquied fuel from water gas
  
2. Element (M) has two oxidation states in which it is diamagnetic in the lower state and paramagnetic in the higher state, and element (Q) has a single oxidation state in which it is diamagnetic and in the atomic state paramagnetic. Which of the following statements is true?
  - a) Element M is more active and more dense than element Q
  - b) Element M is less active and more dense than element Q
  - c) Element M is more active and less dense than element Q
  - d) Element M is less active and less dense than element Q
  
3. Elements (Z, Y, X) are successive transition elements in the first transition series and the largest in atomic number (X) and have the following compounds  $Z_2O_5$ ,  $K_2Y_2O_7$ ,  $KXO_4$   
The correct order of the elements according to their magnetic moment is:
  - a)  $Y > X > Z$
  - b)  $X > Z > Y$
  - c)  $X > Y > Z$
  - d)  $Y > Z > X$



لضمان التفوق ابحاث دائما عن موقع مدرستك

4. A company changed the material from which cell phone bodies are made from a stainless steel alloy to a alloy that is lighter, harder, and more resistant to corrosion.

Which of the following elements are common to iron in this alloy?

- a) Carbon and vanadium.
- b) Carbon and titanium.
- c) Chromium and scandium.
- d) Chromium and titanium.

5. Element X is all diamagnetic, and element Y is preceded by element X in the first transition series

Which of the following is true of an alloy consisting of two elements (Y) and (X)?

- a) It is used in the manufacture of (MiG) fighter.
- b) It is used in the manufacture of railway tracks.
- c) It has high hardness and corrosion resistance.
- d) It can be prepared by electrodeposition

6. From the following two reactions:

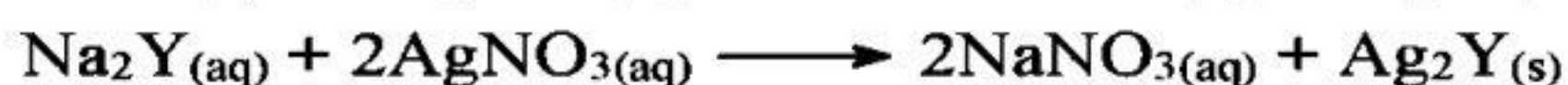

If you know that (  $\text{Ag}_2\text{X}$  ) is black at room temperature and (  $\text{Ag}_2\text{Y}$  ) is black after being heated

Which of the following is true for the acid of both salts?

Choices	Acid of salt $\text{Na}_2\text{Y}$	Acid of salt $\text{Na}_2\text{X}$
A	$\text{H}_2\text{S}_2\text{O}_3$	$\text{H}_2\text{SO}_3$
B	$\text{H}_2\text{S}_2\text{O}_3$	$\text{H}_2\text{S}$
C	$\text{H}_2\text{S}$	$\text{H}_2\text{SO}_3$
D	$\text{H}_2\text{SO}_3$	$\text{H}_2\text{S}$



لضمان التفوق ابحث دائما عن موقع مدرستك

7. Which of the following substances reacts with concentrated sulfuric acid to give a gas that is not detected by a solution acidified potassium dichromate?
- Iron(II) nitrite.
  - Sodium iodide.
  - Potassium bromide.
  - Silver chloride.

8. From the following reaction:

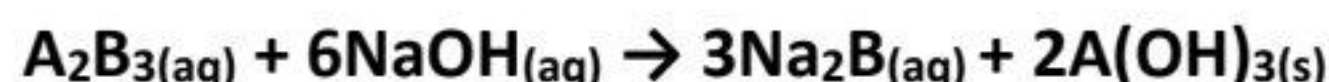

When lead (II) acetate solution is added to  $Na_2B$  salt solution, a white precipitate is formed.

When  $A(OH)_3(s)$  is heated, it turns red. Which of the following is the chemical formula for salt  $A_2B_3$ ?

- $Fe_2(CO_3)_3$
  - $Al_2(CO_3)_3$
  - $Al_2(SO_4)_3$
  - $Fe_2(SO_4)_3$
9. Which of the following substances is insoluble in both sodium hydroxide and ammonia solutions and soluble in diluted hydrochloric acid?
- Aluminum hydroxide and iron (II) hydroxide.
  - Aluminum hydroxide and iron (III) hydroxide.
  - Aluminum hydroxide and sodium meta-aluminate.
  - Iron (II) hydroxide and iron (III) hydroxide.
10. Which of the following reactions is shown in the diagram below?
- Sodium chloride solution + silver nitrate.
  - Reaction of acetic acid and with ethyl alcohol.
  - Reaction of sodium with diluted sulfuric acid.
  - Magnesium pieces + diluted hydrochloric acid.

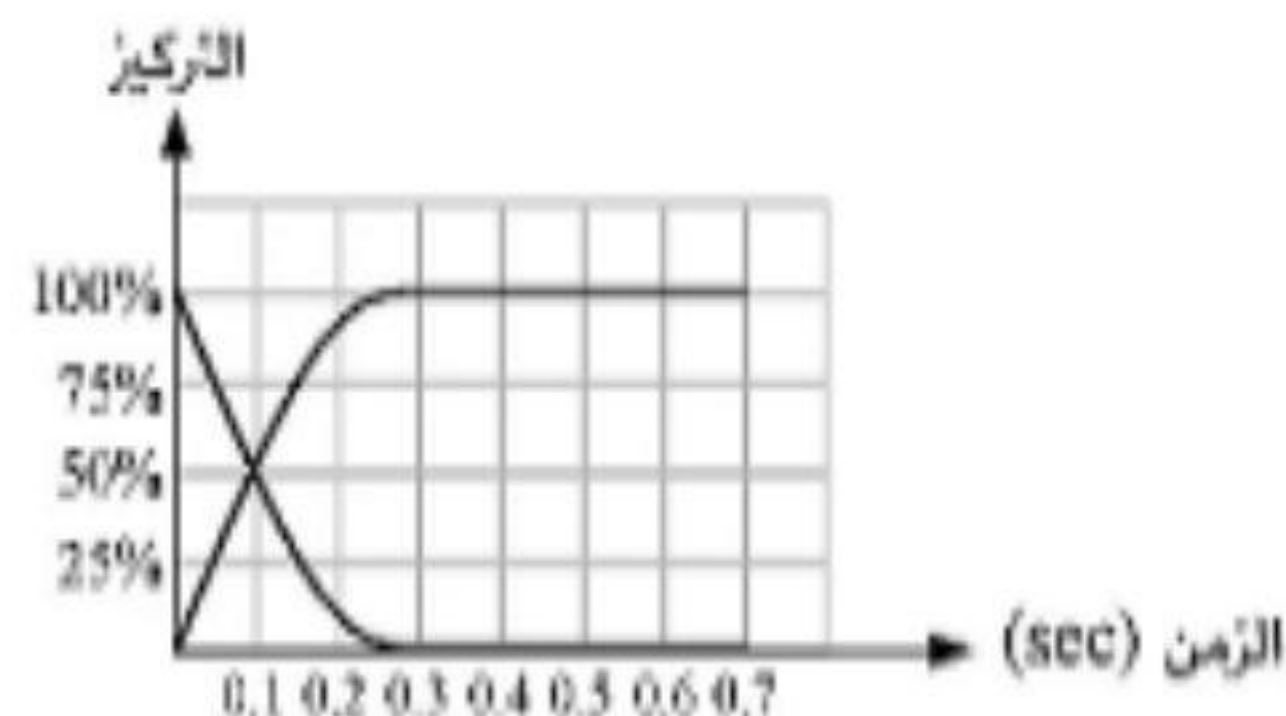

11. From the equilibrium reaction:



at equilibrium in a closed vessel with a volume of 2000 ml , The mass of nitrogen gas was 5.6 g. and the volume of hydrogen gas is 8.96 L at atm ,The number of molecules of ammonia gas is  $3.01 \times 10^{23}$  molecules, which of the following the value of the equilibrium constant ? (N=14)

- a) 19.53
- b) 6.25
- c) 78.125
- d) 12.5

12. Through the following reaction:



When the volume of the vessel is decreased with continued heating, what is the expected value of the equilibrium constant?

- a) Increasing and then decreasing
- b) decreases
- c) increases
- d) decreases and then increases

13. In the following equilibrium reaction



Which of the following expresses the best conditions for obtaining the largest amount of nitric oxide?

- a) Decreasing the volume of the vessel, increasing the temperature.
- b) Increasing the volume of the vessel, and decreasing the temperature.
- c) Adding more  $\text{O}_2$  gas, increasing the temperature.
- d) Adding more  $\text{N}_2$  gas, and decreasing the temperature.



14. What type of following reaction with respect to the standard hydrogen electrode?



- a) Spontaneous anodic reaction
- b) Non-spontaneous anodic reaction
- c) Spontaneous cathodic reaction
- d) Non-spontaneous cathodic reaction

15. When equal mass pieces of metals with symbols (W), (M), (Y), (X) were added to equal volumes of a 1 M HCl solution. it was observed that:

- (W), (M), (Y) react with HCl and (X) does not react with HCl
- The reaction speed of metal (W) is greater than that of metal (Y)
- A solution of metal (M) can be kept in containers made of each of the metals (X), (W), and (Y).

Which of the following are the electrodes of a galvanic cell with the greatest electromotive force?

- a) W, X
- b) W, M
- c) M, Y
- d) M, X

16. The conversion of  $YO(OH)$  to  $Y(OH)_2$  at the – pole in an electrochemical cell represents:

- a) Oxidation during the discharge process.
- b) Reduction during the discharge process.
- c) Oxidation during the charging process.
- d) Reduction during the charging process.

17. The following table shows the standard reduction efforts for elements (A, B, C, and D)

Element	A	B	C	D
Reduction potential	+ 0.85V	+ 0.34 V	- 1.16 V	- 1.35 V

The choice that expresses anodic protection is :

- Element B is coated with element C
- Element B is coated with element A
- Element D is coated with element C
- Element D is coated with element A

18. The opposite diagram shows the relationship between the concentration (C) of four aqueous solutions of four different acids and the concentration of hydrogen ions  $[H^+]$  in them. Which of the following is correct?

- The value of  $[OH^-]$  in solution (X) is equal to the value of  $[H^+]$  in solution(Y).
- Solutions (Y) and (B) have the same ionization constant.
- Acid (A) is strong, the pH of its solution is lower than that solution (X)
- The pH value of solution (Y) is equal to its pOH value.

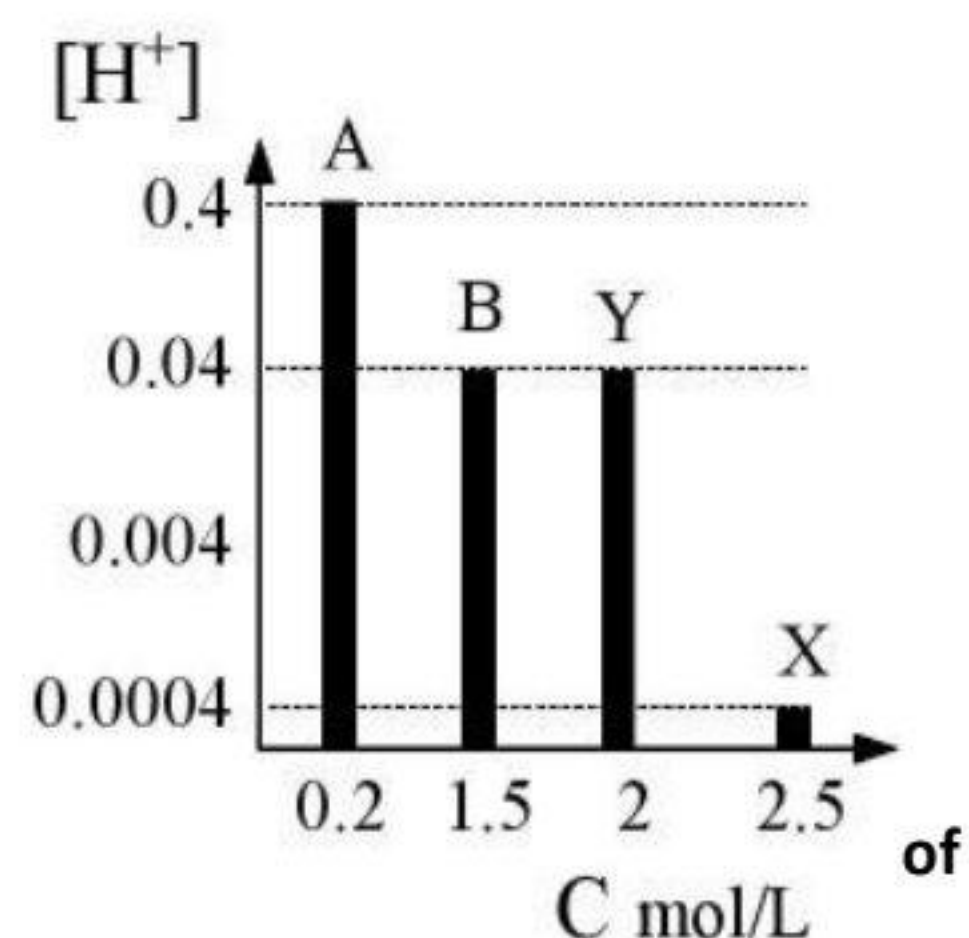

19. You have two solutions, one with litmus solution and one with bromothymol blue solution, both of which are blue in color. Which of the following solutions can you distinguish between them?

- $Fe(NO_3)_3$
- $Na_2CO_3$
- $CH_3COONa$
- $K_2SO_4$

20. You have two separate solutions of sodium hydroxide and ammonia that have the same volume and concentration, the ammonia solution
- Has a greater electrical conductivity than the sodium hydroxide solution.
  - It has a lower concentration of  $(H^+)$  ions than sodium hydroxide solution.
  - The concentration of  $(OH^-)$  ions is greater than that of sodium hydroxide solution.
  - Its pH value is lower than the pH value of the sodium hydroxide solution.
21. When a moist paper with starch solution is exposed to the gas from the electrolysis of cesium bromide melt, it turns
- Yellow
  - Red
  - blue
  - green
22. To make a layer of tin on the surface of a copper stem, an analytical cell is made, and which of the following represents this cell?
- An anode of a copper rod , a cathode of tin, and an electrolyte containing  $Sn^{2+}$  ions.
  - An anode of a copper rod , a tin cathode, and an electrolyte containing  $Fe^{2+}$  ions.
  - An anode of tin, a cathode of a copper, and an electrolyte containing  $Sn^{2+}$  ions.
  - An anode of iron, a cathode of a copper, and an electrolyte containing  $Fe^{2+}$  ions.
23. Which of the following substances when heated with an abundance of oxygen forms a mixture of two compounds, one of which forms a white precipitate with calcium hydroxide, and the other turns anhydrous copper sulfate into blue ?
- Gasoline.
  - Ammonium cyanate.
  - Sodium carbonate.
  - Carbon tetrachloride.

24. What is the correct IUPAC name for the compound iso-propylbutane?

- a) 2-propylbutane.
- b) 2 - iso-propylbutane.
- c) 3 - Methylhexane.
- d) 2,3-Dimethylpentane.

25. Which of the following are the steps needed to obtain water gas from heptane?

- a) Dry distillation - catalytic thermal cracking.
- b) Dry distillation - reaction with water vapor.
- c) Combustion - dry distillation.
- d) Combustion - reaction with methane.

26. B and A are organic compounds with the molecular formula:

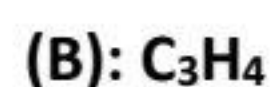

Which of the following is the general formula that expresses the compounds resulting from the catalytic hydration of each of them separately?

- a)  $C_nH_{2n-2}O$
- b)  $C_nH_{2n}O$
- c)  $C_nH_{2n+2}O_2$
- d)  $C_nH_{2n+2}O$

27. Which of the following is the compound produced when ethylbutene reacts with hydrogen bromide?

- a) 3-bromo-3-methylpentane
- b) 3-bromo-2-methylpentane
- c) 2-bromo-2-methylbutane
- d) 3-bromohexane

28. Which of the following represents the use of the polymerization product of compound (X) in

addition:  $C_nH_{2n-2} + HCl \rightarrow X$

- a) Floor insulation.
- b) Plastic bags.
- c) Plastic cans and bottles.
- d) Lining Cooking pots.

29. Study the following diagram.

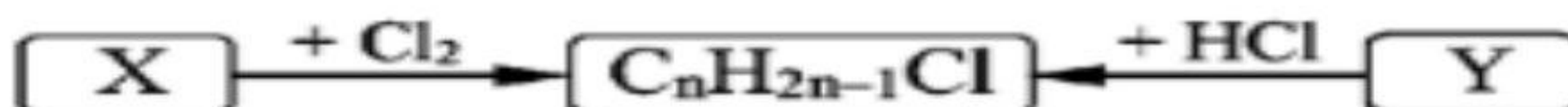

Which of the following is true for compounds (X and Y)?

- a) (X) Cycloalkane and (Y) alkene.
- b) (X) Alkene and (Y) alkene.
- c) (X) Cycloalkane and (Y) alkyne.
- d) (X) Normal alkane and (Y) alkene.

30. Study the following chart:

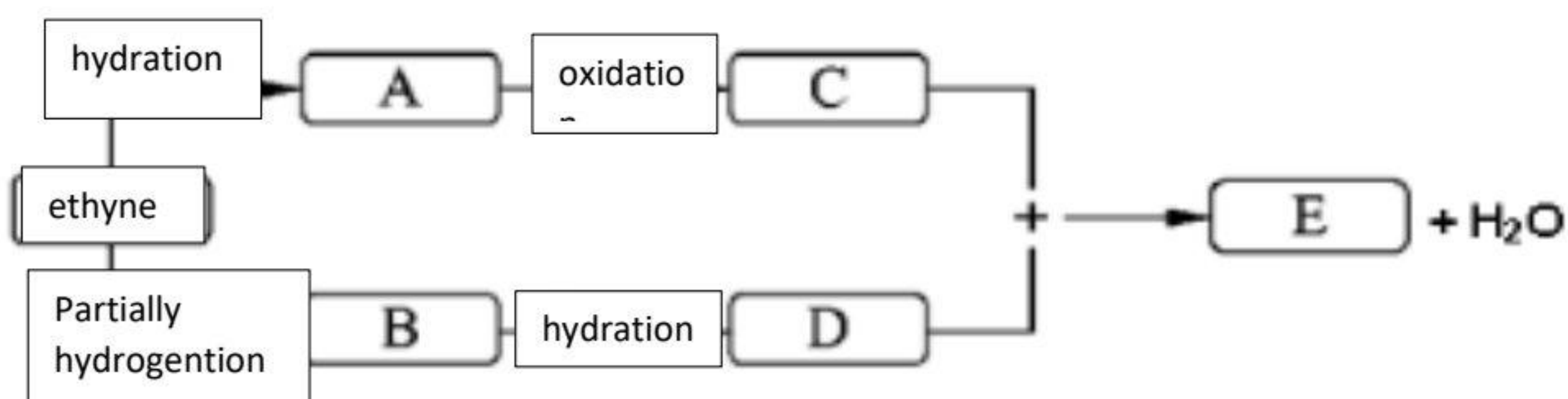

What is the IUPAC name for compound (E)?

- a) Methyl methanoate.
- b) Ethyl acetate.
- c) Ethyl ethanoate
- d) Propyl propanoate.

31. from the following reaction diagram (which occurs under the right conditions

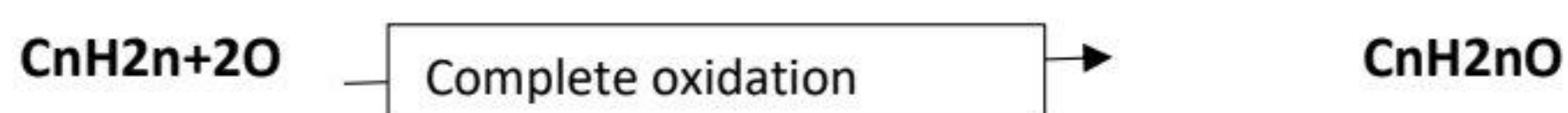

Which of the following is the compound (A and B) .

- a) (A), secondary alcohol (B), keton
- b) (A) primary alcohol, (B) aldehyde
- c) (A) secondary alcohol, (B) aldehyde
- d) (A) primary alcohol, (B) ketone

32. What is the name of the monomer that gives the following polymer by condensation?

- a) Propanoic acid.
- b) Methanol and acetic acid.
- c) Ethanol and acetic acid.
- d) Lactic acid.

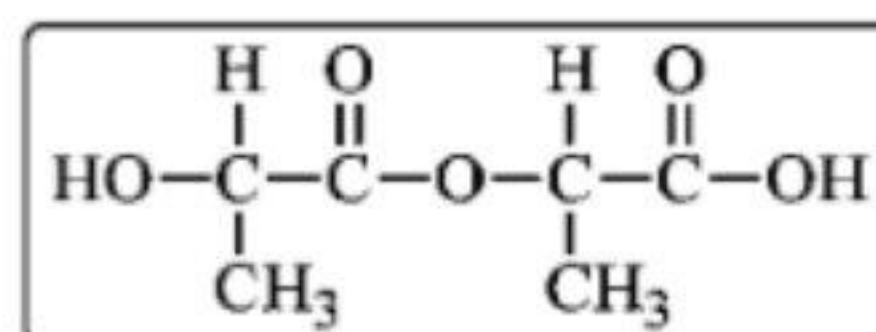

33. An iron-copper alloy of mass g 4 is placed in dilute HCl acid and 1.12 H<sub>2</sub> gas is vaporized in STP  
When the same alloy is placed in concentrated nitric acid, the volume of reddish-brown gas  
vaporized in liter equals :( Fe =56 & Cu=63.5)

- a) 22.4
- b) 11.2
- c) 0.846
- d) 1.12

34. Adding 20 ml of limewater of concentration 0.1 M was added to 12 ml of hydrochloric acid of  
concentration 0.5 M, and after enough time to complete the titration; 10 ml of sodium hydroxide  
solution was added.

Which of the following is the concentration of the sodium hydroxide solution?

- a) 0.05
- b) 0.1
- c) 0.2
- d) 0.45

35. 2.86 g of washing soda  $\text{Na}_2\text{CO}_3 \cdot 10\text{H}_2\text{O}$  when heated, part of the water evaporated till its mass become of 1.78 g, so the number of water mole volatilized is: (Na=23, C=12, O=16, H=1)
- 0.05
  - 0.04
  - 0.06
  - 0.07
36. An impure limestone sample with a mass of 4 g after the end of decomposition, and the volume of evolved gas is 0.6 L ( Ca=40 , C=12 ,O=16)
- According to the following equation:  $\text{CaCO}_3 \rightarrow \text{CaO} + \text{CO}_2$
- What is the percentage of impurities in the sample? (assuming the impurities do not react)
- 4.8%
  - 0.8%
  - 20%
  - 33%
37. Which of the following methods is not used to prepare an aromatic compound with molecular formula  $\text{C}_8\text{H}_{10}$ ?
- Reaction of methyl chloride with toluene in the presence of anhydrous aluminum chloride.
  - Reaction of ethyl chloride with toluene in the presence of anhydrous aluminum chloride.
  - Reaction of ethyl chloride with benzene in the presence of anhydrous aluminum chloride.
  - Heating normal octane in the presence of platinum.
38. Which of the following processes is performed to convert a compound with the general formula  $(\text{C}_n\text{H}_{2n+2})$  to a compound with the general formula  $(\text{C}_n\text{H}_{2n+2}\text{O})$ ?
- Extreme heating and rapid cooling - polymerization - hydrogenation
  - Remodeling - alkylation - hydrogenation
  - Halogenation - base hydrolysis - oxidation
  - Extreme heating and rapid cooling - catalytic hydrogenation - reduction

39. When  $H_2O$  reacts with three organic compounds (A, B, and C) under the suitable conditions separately, it forms, respectively (a mixture of two gases - a secondary alcohol - a ketone) compounds A, B, and C are:

- (A) Methane - (B) ethane Methane - (B) Ethane - (C) Ethane.
- (A) Ethane - (B) ethene - (C) ethene.
- (A) methane - (B) propene - (C) propyne
- (A) ethane- (B) propene- (C) propyne

40. from the following diagram:

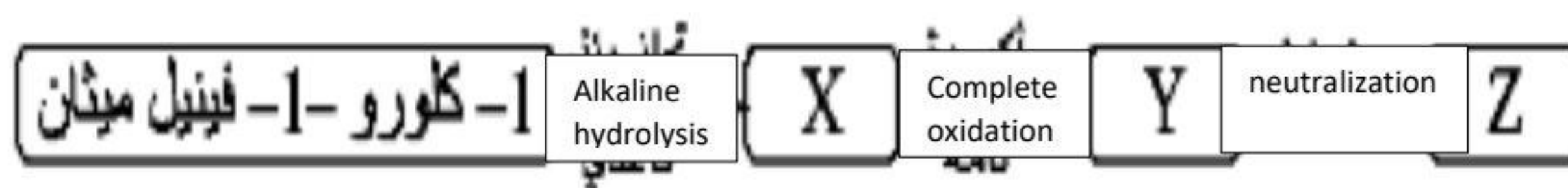

Which of the following are the uses of compound (Z)?

- Preserving substance.
- Electrical tools.
- Explosive.
- Pesticide.

41. From the diagram below:

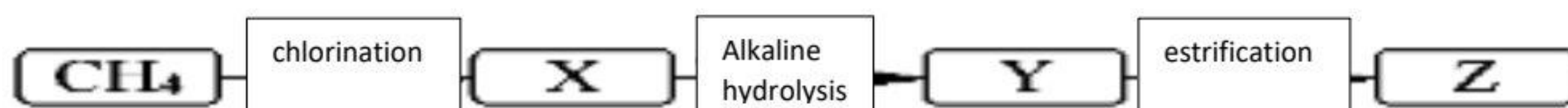

Which of the following represents compound Z?

- Marookh oil.
- Aspirin.
- Dacron fiber.
- Ethyl ethanoate.

42. What is the solubility of  $Y(OH)_2$  salt if you know that the pH value of its saturated solution is 12?

- $1 \times 10^{-4}$
- $1 \times 10^{-2}$
- $5 \times 10^{-3}$
- $5 \times 10^{-7}$

43. An amount of electricity of 48250 C passes into a solution of copper (II) chloride, so if an amount of electricity passes into a solution with a volume of 2 L. What was the concentration of that solution? [Cu = 63.5 & Cl = 35.5]

- a) 0.375 mol/L
- b) 0.75 mol/L
- c) C. 0.125 mol/L
- d) 0.18 mol/L

44. When a current of 40.2 A is applied to an electrolyte containing a solution of metal (X) sulfate, 1 mole of metal (X) is precipitated after a time of 1 hour and 20 minutes.

What is the chemical formula of metal oxide (X)?

- a)  $X_2O$
- b)  $XO$
- c)  $X_2O_3$
- d)  $XO_2$



➤ **Second: answer the following essay questions:**

45. From the diagram below:

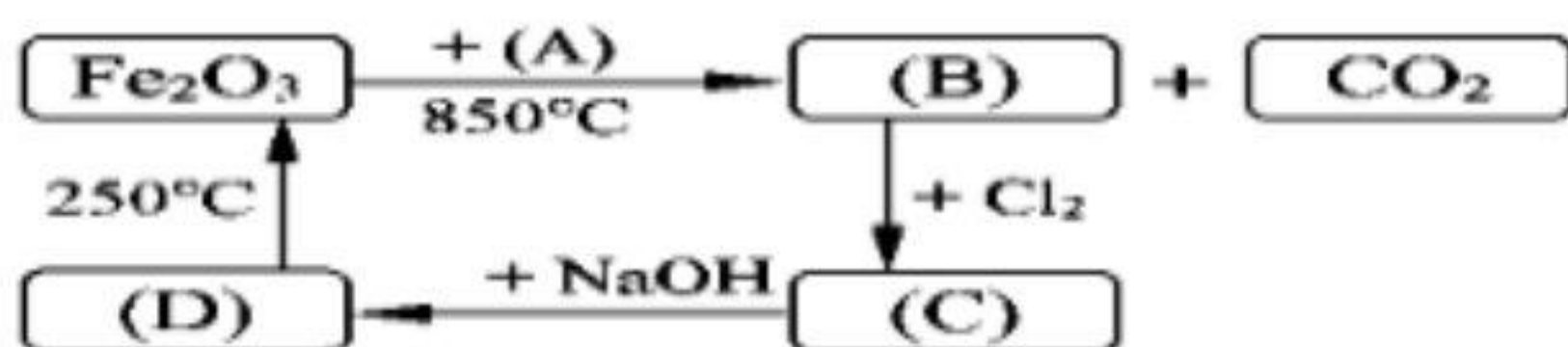

Derive the chemical formula for?

a) Substances that do not dissolve in water but react with dilute hydrochloric acid

.....  
.....

b) Substances that have the same magnetic moment

.....  
.....

46. The catalytic hydration of compound ( X ) forms compound ( Y ), the oxidation of compound ( Y ) forms compound ( Z ), the catalytic hydration of compound ( A ) forms compound B, and the reaction of B with Z forms ethyl ethanoate

Answer the following:

a) What is the chemical formula of compounds (X) and (A)?

.....  
.....

b) What is the name of the chemical process needed to get (Y (B)?

.....  
.....

## **expermental exam 2025- model (10 )**

➤ **First: choose the correct answer:**

1. Element A is a transition series element whose magnetic moment decreases as its oxidation number increases.

Which of the following is this element?

- a) It is a coinage element.
  - b) It does not give an oxidation state in which all the S, d electrons are ejected
  - c) Its maximum oxidation state is equal to its group number
  - d) It has a lower atomic mass than the preceding element
2. When four tubes (titanium chloride III, titanium chloride IV, manganese chloride II, and manganese chloride III) are placed and acidified potassium permanganate.
- Which of the following processes is correct?
- a) Titanium III chloride is converted to titanium IV chloride
  - b) Titanium IV chloride is converted to titanium III chloride
  - c) Manganese(II) chloride is converted to manganese(III) chloride
  - d) Manganese III chloride is converted to manganese II chloride
3. All of the following describe a transition element in the first transition series that gives one oxidation state except?
- a) Only The outermost energy level of its atom is incomplete
  - b) Its atom has a number of electrons in the d-sublevel (equal to half the number in the s-sublevel)
  - c) Its atom is paramagnetic but its cation is a diamagnetic
  - d) The last principal level of its atom has only two electrons



4. Which of the following processes is performed on blast furnace cleaning products and other fine iron ore to produce an alloy used in car springs, respectively?
- Sintering-reduction- combining vanadium during production
  - Sintering-reduction-addition of vanadium during production
  - Concentration - oxidation - oxidation - reduction - addition of vanadium during production
  - Cracking - Reduction - Addition of Vanadium during production
5. The final product when iron heated to red hot at  $500^{\circ}\text{C}$  reacts with water vapor in a closed vessel is:
- $\text{Fe}_3\text{O}_4$
  - Fe
  - $\text{Fe}_2\text{O}_3$
  - FeO
6. Which of the following diagrams shows the relationship between the mass of a solid and time when siderite is roasted?

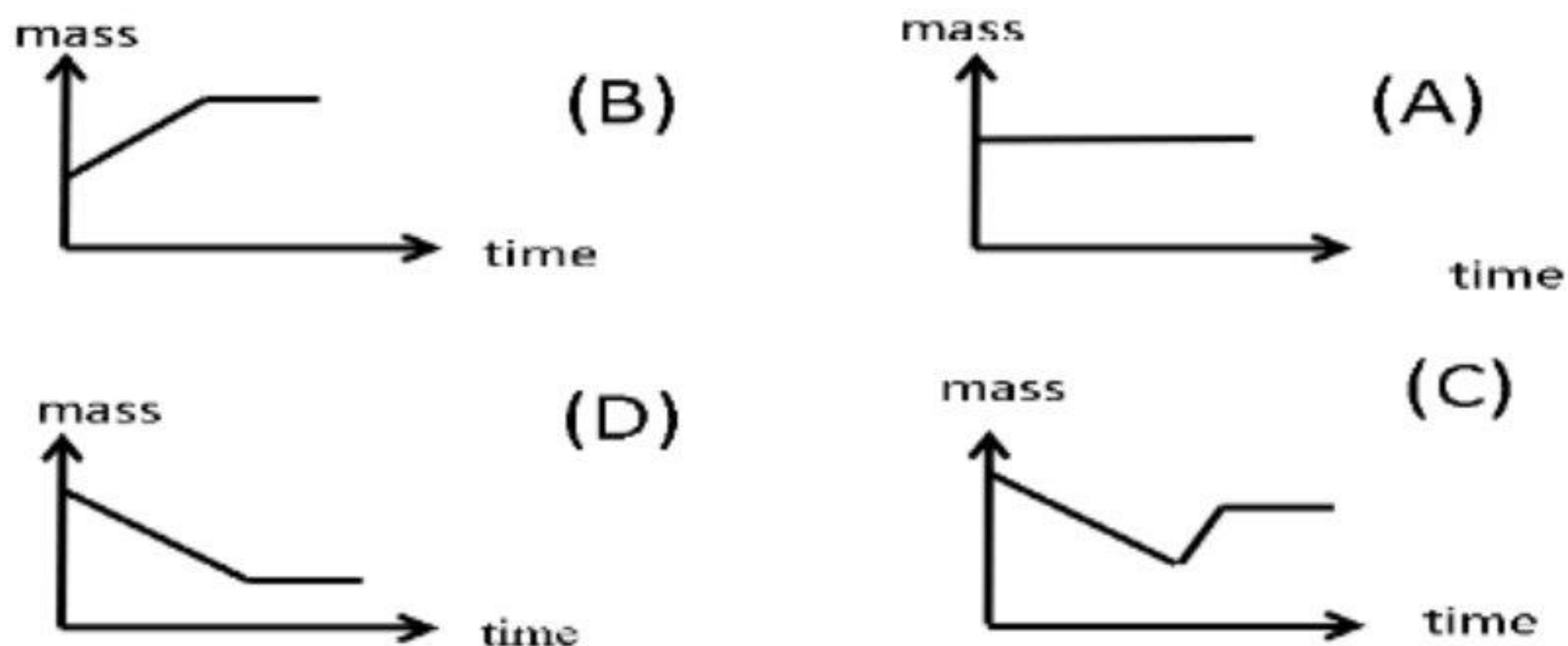

7. Potassium bicarbonate and potassium carbonate solutions can be practically distinguished by using :
- sodium nitrate solution
  - distilled water
  - Barium chloride solution
  - Dilute hydrochloric acid

8. Red-brown vapors will be observed at the mouth of the test tube in all of the following cases except:
- adding a copper turner to concentrated nitric acid
  - Adding hot concentrated sulfuric acid to  $\text{KNO}_3$  salt
  - Shaking a tube containing a brown ring compound
  - Adding dilute hydrochloric acid to  $\text{NaNO}_3$  salt
9. When 2 moles of aluminum chloride reacts with 7 moles of caustic soda, the product will be:
- a clear solution
  - a gelatinous reddish-brown precipitate
  - a white gelatinous precipitate
  - Greenish-white precipitate
10. In the hydrated salt  $\text{MCl}_2 \cdot \text{XH}_2\text{O}$ , 0.4 mol anhydrous salt is linked with 14.4 g of water - if you know that the molar mass of the hydrated salt = 244 g/mol, then the atomic mass of the metal M is : [Cl = 35.5, O = 16, H = 1]
- 24 g/mol
  - 137 g/mol
  - 40 g/mol
  - 172 g/mol
11. A sample (Y) of sodium chloride salt has a purity of 48.92% when dissolved in water to make a solution and when excess of silver nitrate solution is added to form a precipitate of mass 12 g. What is the mass of the sample? [Ag = 108, Cl = 35.5, Na = 23]
- 5
  - 16 g
  - 10 g
  - 2 g

12. Relation  $(M_a \cdot V_a) = 3/2 (M_b \cdot V_b)$  is suitable for use when titrating:

- a) hydrochloric acid with barium hydroxide
- b) phosphoric acid with sodium hydroxide
- c) sulfuric acid with sodium hydroxide
- d) phosphoric acid with barium hydroxide

13. The following reaction has two values for the equilibrium constant and two values for temperature



Which of the following is true?

- a) The reaction to form HBr is endothermic
- b) The HBr formation reaction is exothermic
- c) The HBr dissociation reaction is dominant
- d) The type of forward and reverse reaction cannot be determined

14. In the following balanced reaction:

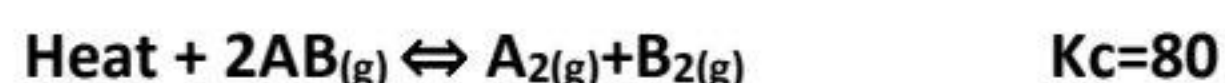

Upon decreasing the temperature if you know that before decreasing the temperature the concentrations of  $[\text{A}] = 2\text{M}$ ,  $[\text{B}] = 2\text{M}$ . The concentration of AB is:

- a) 0.05M
- b) 0.233M
- c) 0.1M
- d) 0.3M

15. If the solubility degree of a salt equals to half the concentration of its cations in solution of a sparingly soluble salt. This salt is:

- a) potassium carbonate
- b) silver phosphate
- c) barium carbonate
- d) silver carbonate

16. Which of the following causes increasing of speed of a chemical reaction by increasing of temperature?
- a) increasing the difference in energy of reactants and products
  - b) Decrease in the reaction speed constant
  - c) Increase in the number of molecules which have activation energy
  - d) Decrease in activation energy
17. Which of the following occurs during exposing of the photographic films to the light?
- a)  $\text{Ag}^+$  ions are reduced and  $\text{Br}^-$  ions are reduced
  - b)  $\text{Ag}^+$  ions are reduced and  $\text{Br}^-$  ions are oxidized
  - c)  $\text{Ag}^+$  ions are oxidized and  $\text{Br}^-$  ions are reduced
  - d) Ag atoms are reduced and Br atoms are reduced
18. An aqueous solution of a weak acid with an ionization constant of  $1.43 \times 10^{-5}$  is ionized by 1.47%. Then the concentration of  $\text{H}_3\text{O}^+$  ions is:
- a)  $2.10 \times 10^{-7}$  M
  - b)  $4.87 \times 10^{-4}$  M
  - c)  $6.62 \times 10^{-2}$  M
  - d)  $9.73 \times 10^{-4}$  M
19. An acidic solution has a pH of 2. After adding a small volume of a base, the pH changes to 4. How much does the concentration of hydrogen ions  $\text{H}^+$  change?
- e) It increases by 2
  - f) decreases by 10
  - g) decreases by 100
  - h) increases by 100

20. In the following reaction:  $2\text{SO}_{2(g)} + \text{O}_{2(g)} \rightleftharpoons 2\text{SO}_{3(g)}$

If you know that the activation energy of a reverse reaction without a catalyst is 190 KJ/mol, the activation energy of a forward reaction without a catalyst is 80 KJ/mol, and the energy of the reactants is 240 KJ/mol, which of the following is true?

- a) Change in heat content = -110 KJ/mol
- b) Energy of the products = 90 KJ
- c) The reaction is endothermic
- d) When a catalyst is added to this reaction, the energy of the products increases and the speed of the reaction increases

21. In a Daniel cell, the anode is made up of Zinc and the cathode is made up of copper, which of the following is true?

Given that the atomic mass [Zn = 65, Cu = 63.5]

- a) Decrease in anode mass = increase in cathode mass.
- b) Decrease in anode mass > increase in cathode mass.
- c) Decrease in anode mass < increase in cathode mass.
- d) The concentration of Zinc ions decreases and the concentration of copper ions increases.

22. Three metals (A, B, and C) whose order of reduction potential is (A < B < C), which of the following statements is true?

- a)  $\text{C}^{2+}$  ions are easily reduced than  $\text{A}^{2+}$  ions.
- b) The oxidation potential of ( B ) is smaller than that of ( C ).
- c) We can store a solution of ( C ) in a container made of metal ( B ).
- d) We can stir solution ( B ) with a spoon made of metal ( A ).

23. When three rods of elements ( Z, Y, and X ) are added to a solution of nickel nitrate II, ( X ) is corroded, ( Y ) is covered with a layer of nickel, and ( Z ) is unaffected. When a galvanic cell is formed from ( Y and X ), the concentration of ( Y ) ions in the solution increases, which of the following expresses the order of the cations of the elements as oxidizing agents?

- a)  $X < Y < Z$
- b)  $Y < X < Z$
- c)  $Z < X < Y$
- d)  $Z < Y < X$

24. in the reaction in an electric cell:

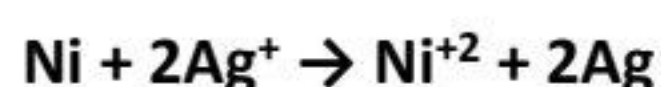

If you that:



Which of the following is correct?

- a) Electrolytic cell, emf = -1.03 v
- b) galvanic cell, emf = +1.03 v
- c) galvanic cell, v emf = +0.564
- d) electrolytic cell , emf = -0.564 v

25. To protect element( A )with element( B) from corrosion. Which of the following is correct?

- a) A withdrawal of electrons from A to B represents anodic protection
- b) A withdrawal of electrons from B, and reduction of oxygen and represents anodic protection
- c) transfer of electrons to A and represents cathodic protection
- d) transfer of electrons between B, A and A represents a sacrificial electrode

26. All of the following occur during the recharging of a lead-acid battery except:

- a) The density of the electrolyte reaches 1.28: 1.3 g/cm<sup>3</sup>.
- b) Lead(II) sulfate is converted to lead at the cathode of the electrolytic cell.
- c) Lead II sulfate converts to lead at the anode of a galvanic cell.
- d) Lead II sulfate converts to lead II oxide at the cathode of the electrolytic cell.

27. A copper spoon of mass 60 g is coated with a layer of silver by passing a current of 10A for 6 min,  
the mass of the spoon after coating is: [Ag = 108]

- a) 4.03g
- b) 64.03g
- c) 2.52g
- d) 52.52g

28. The compound that requires 6 F of electronegativity to precipitate a gram atom of element X is

- a) XO
- b) X<sub>3</sub>O<sub>2</sub>
- c) XO<sub>3</sub>
- d) X<sub>2</sub>O<sub>3</sub>

29. By dry distillation of sodium hexanoate, the resulting compound isomer containing 4 methyl groups is:

- a) 2,2-dimethylpropane
- b) 3-methylbutane
- c) 2,2-dimethylbutane
- d) 3-Methylpentane

30. by catalytic thermal cracking of C<sub>14</sub>H<sub>30</sub> as in the following equation:

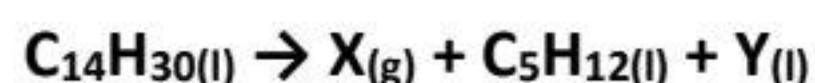

Which of the following compounds ( X and Y)?

- a) (X) ethane(Y) heptane
- b) (X) ethene(Y) heptene
- c) (X) heptene(Y) ethene
- d) (X) two heptane(Y) ethane

31. What is the IUPAC name for the compound (CH<sub>3</sub>)<sub>2</sub>CH(CH<sub>2</sub>)<sub>4</sub>CH<sub>3</sub>?

- a) 2-ethylheptane
- b) 2-methylheptane
- c) 2, 2-dimethylheptane
- d) 2, 2-dimethylhexane

32. The number of methylene groups in a molecule of methylpropene is:

- a) 3
- b) 2
- c) 1
- d) 0

33. From the following diagram:



Which of the following is true for both A and B?

- a) B only reacts by addition
- b) A, B react by substitution
- c) A and B react by addition and substitution
- d) A reacts by substitution only

34. The steps to obtain gamixan from calcium carbide are:

- a) dropping water - polymerization - halogenation
- b) dropping water - hydrogenation - oxidation
- c) dropping water - polymerization - hydrogenation
- d) dropping water - hydrogenation - hydrogenation

35. Which of the following is correct for obtaining an explosive from an aliphatic compound?

- a) reformation - nitration
- b) Heating and cooling - nitriding
- c) Polymerization - nitration
- d) dropping water - Polymerization - Nitration

36. How many isomers of the molecular formula  $C_4H_{10}O$  do not decolorize a solution of acidified potassium permanganate?

- a) 3
- b) 4
- c) 6
- d) 7

37. What is the IUPAC name for the compound resulting from the reduction of the corresponding compound?

- a) 2-methyl-butanoic acid
- b) 2-methyl-propanoic
- c) 2-methyl-1-propanol
- d) 2-methyl-1-butanal

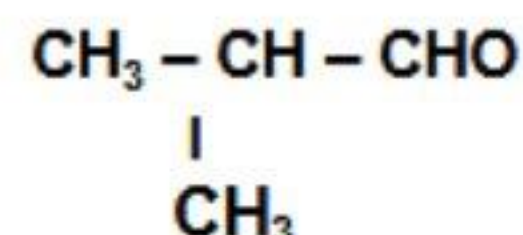

38. The suitable compound that produces 1,1,1,1-trichloro-2-propanol by catalytic hydration is:

- a) 1,1,1-trichloro-3-propene
- b) 1,1,1-trichloro-2-propene
- c) 3,3,3-trichloro-1-propene
- d) 3,3,3-trichloro-1-propane

39. Which of the following are the correct steps to obtain an explosive and burn treatment from sodium benzoate?

- a) Dry distillation \ nitration \ alkaline hydrolysis \ halogenation
- b) Dry distillation \ halogenation \ alkaline hydrolysis \ nitration
- c) alkaline hydrolysis \ dry distillation \ halogenation \ nitration
- d) Dry distillation \ alkaline hydrolysis \ halogenation \ nitration

40. A, B and C are three aliphatic organic compounds.

Alkaline hydrolysis of A gives B and dry distillation of B gives C. Which of the following the compounds A, B, and C are:

- a) A: Ethanoic                      B : Sodium ethanoate                      C: Methane
- b) A: Methyl benzoate      B : Sodium methanolate                      C :methane
- c) A : Ethyl ethanoate      B : Sodium ethanoate                      C : Methane
- d) A : Ethyl ethanoate      B : Sodium ethanoate                      C : Ethane

41. The compound resulting from the alkaline hydrolysis of  $C_3H_7Br$  containing a single methyl group is:
- a secondary alcohol only
  - primary alcohol only
  - primary or secondary alcohol
  - Primary alcohol or tertiary alcohol
42. What is the correct isomeric name for the following compound  $C_6H_5OOCCH_2CH_3$ ?
- Ethyl benzoate
  - phenyl ethanoate
  - propyl benzoate
  - phenyl propanoate
43. Marookh oil can be obtained from aspirin by:
- alkaline hydrolysis followed by reaction with an organic acid
  - Acid hydrolysis followed by esterification with a primary alcohol
  - Starch hydrolysis followed by reaction with ethanoic acid
  - alkaline hydrolysis followed by reaction with ethanol
44. An organic compound A reacts with an organic compound B to produce a substance that has a role in the treatment of heart disease:
- A is a dibasic acid, B is a dihydroxyl alcohol
  - A phenol, B formaldehyde
  - A phenol, B dihydroxyl alcohol
  - A trihydroxyl alcohol, B mineral acid

➤ **Second: answer the following essay questions:**

45. When 6.6 grams of aqueous manganese chloride  $MnCl_x \cdot 4H_2O$  is heated with 4.2 grams of dry salt, the oxidation state of the manganese is: [Mn =55, Cl =35.5, O =16, H =1]

.....  
.....

If you know that A, B and C are three transition elements located in the fourth period.

A: an element that does not react with all acids except concentrated nitric acid.

B: an element that is smaller atomic mass than the element before and after in the same period.

C: an element that is highly chemically active but resistant to weathering.

a) Arrange these elements in order of density.

.....  
.....

b) Arrange the divalent ions of these elements in order of magnetic moment.

.....  
.....