

# Geometry

Grade 9

2nd term

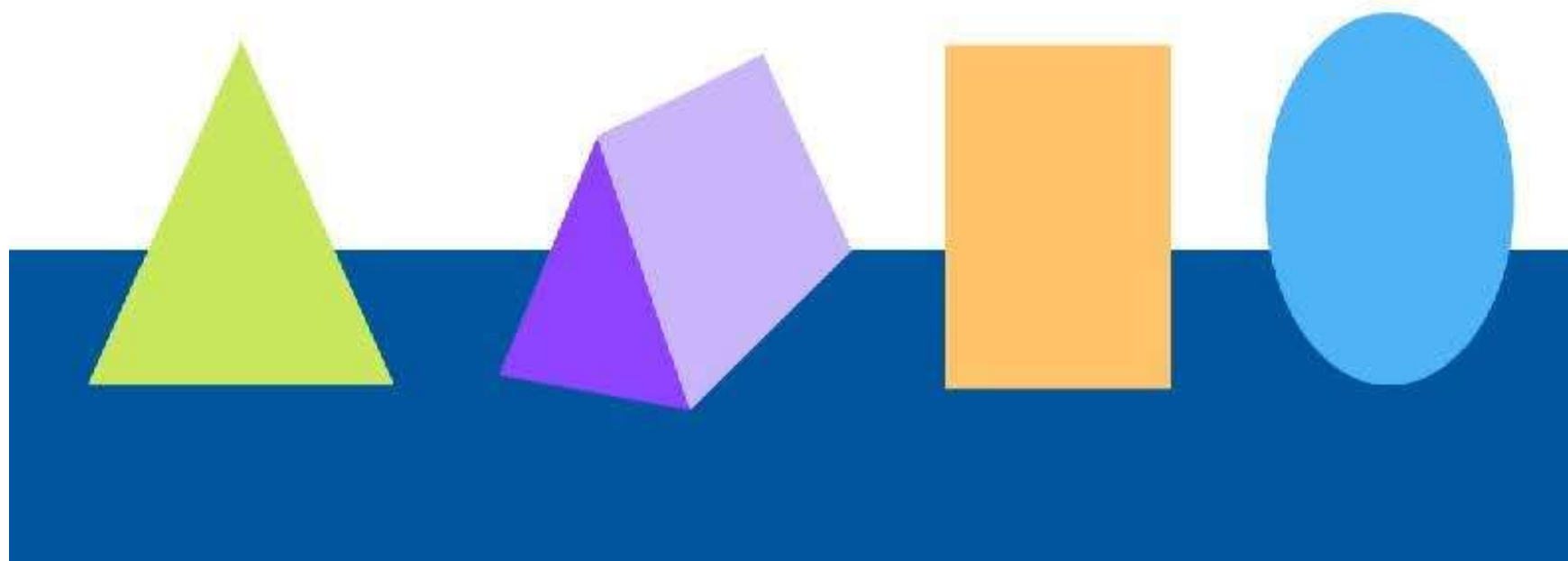

**Unit 4 | Lesson 1**  
**" Basic definitions and concepts on the circle "**

**Q1**

In the opposite figure:

$\overline{AB}$  and  $\overline{BC}$  are two chords in circle  $M$ ,  
 which has radius length of  $5\text{ cm}$ ,  
 $\overline{MD} \perp \overline{AB}$  intersects  $\overline{AB}$  at  $D$  and intersects the circle  $M$  at  $E$ ,  
 $X$  is the midpoint of  $\overline{BC}$ ,  $AB = 8\text{ cm}$ ,  $m(\angle ABC) = 56^\circ$

Find:

1.  $m(\angle DMX)$
2. The length of  $\overline{DE}$

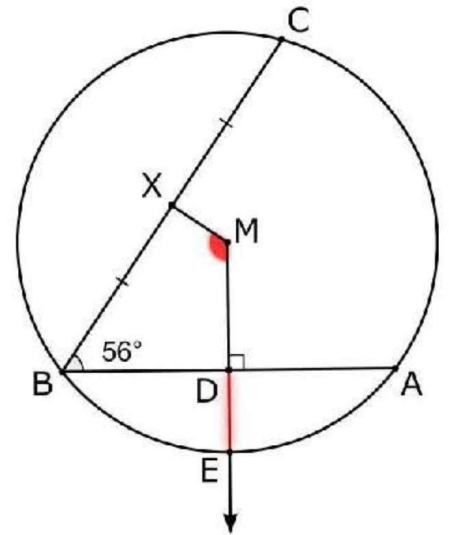

**Solution**

$\therefore X$  midpoint of  $\overline{BC}$   
 $\therefore \overline{MX} \perp \overline{BC}$   
 $\therefore MXBD$  quadrilateral  
 $\therefore m(\angle DMX) = 360 - (56 + 90 + 90) = 124^\circ$

Draw  $\overline{AM}$   
 $\therefore \overline{MD} \perp \overline{AB}$   
 $\therefore D$  is midpoint of  $\overline{AB}$   
 $\therefore AD = 4\text{ cm}$

in  $\triangle AMD$   
 $AM = r = 5\text{ cm}$   
 $\therefore MD = \sqrt{5^2 - 4^2} = 3\text{ cm} \leftarrow \text{Pythagoras}$

$EM = r = 5\text{ cm}$   
 $DE = 5 - 3 = 2\text{ cm}$

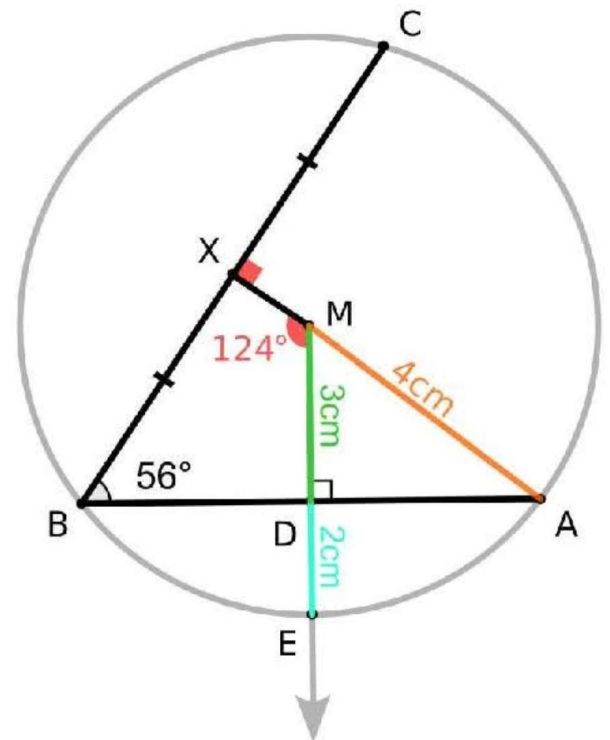

**Q2**

In the opposite figure:

M is a circle of radius length 13 cm,

AB is a chord of length 24 cm,

C is the midpoint of AB

And MC circle M={D}

- Find: The area of the triangle AD

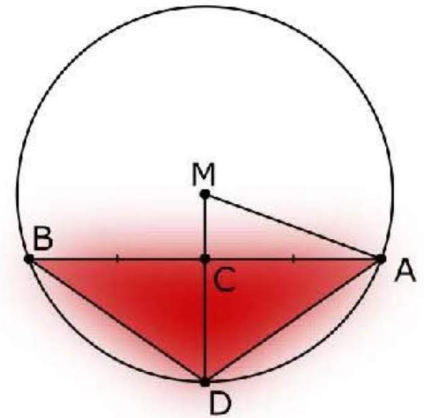

**Solution**

$\because$  C midpoint of AB

$\therefore MC \perp AB$

$\therefore AC = 24 \div 2 = 12 \text{ cm}$

In  $\triangle ACM$

$AM = r = 13 \text{ cm}$

$MC = \sqrt{13^2 - 12^2} = 5 \text{ cm} \leftarrow \text{Pythagoras}$

$CD = 13 - 5 = 8 \text{ cm}$

Area of  $\triangle ABD = \frac{1}{2} \times \text{base} \times \text{height}$

$$= \frac{1}{2} \times 24 \times 8 = 96 \text{ cm}^2$$

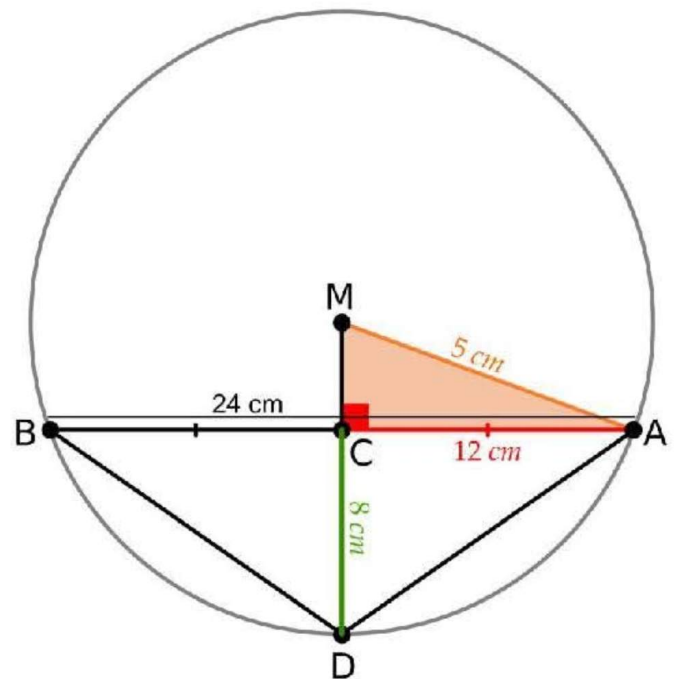

**Q3**

In the opposite figure:

$M$  is a circle ,  $\overline{AB} // \overline{CD}$  ,

$X$  is the midpoint of  $\overline{AB}$

And  $\overline{XM}$  is drawn to cut  $\overline{CD}$  at  $Y$

- Prove that:  $Y$  is the midpoint of  $\overline{CD}$

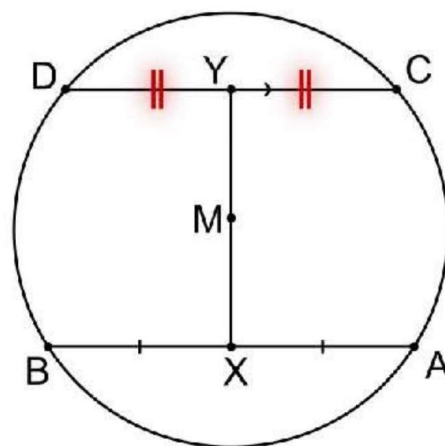

**Solution**

$X$  midpoint of  $\overline{AB}$

$\therefore MX \perp AB$

$\because AB // DC$

$\therefore MY \perp DC$

$\therefore Y$  is midpoint of  $DC$

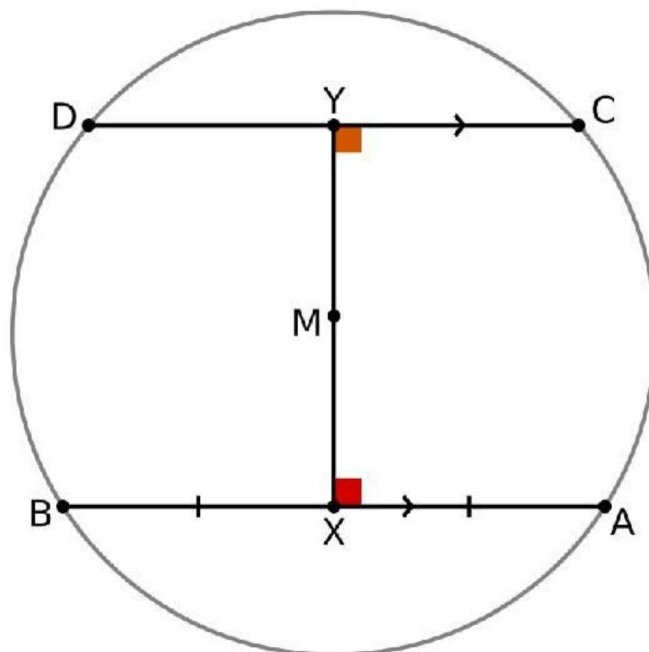

**Q4**

In the opposite figure:

$\overline{AB}$  and  $\overline{AC}$  are two chords in circle  $M$

That included an angle of measure  $120^\circ$ ,

$D$  and  $E$  are the two midpoints of  $\overline{AB}$  and  $\overline{AC}$  respectively,

$\overline{DM}$  and  $\overline{EM}$  are drawn to intersect the circle at  $X$  and  $Y$  respectively.

- Prove that :  $\triangle XYM$  is an equilateral triangle.

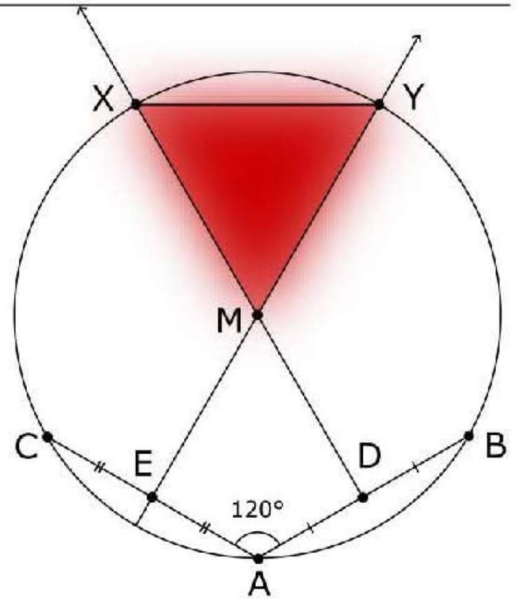

**Solution**

$\because D$  midpoint of  $\overline{AB}$   
 $\therefore \overline{MD} \perp \overline{AB}$

$\because E$  midpoint of  $\overline{AC}$   
 $\therefore \overline{ME} \perp \overline{AC}$

$\because ADME$  is quadrilateral  
 $\therefore m(\angle DME) = 360 - (120 + 90 + 90) = 60^\circ$

$\because m(\angle XMY) = m(\angle DME) = 60^\circ \Leftarrow (V.O.A)$   
 $\therefore MX = MY = r$   
 $\therefore \triangle XMY$  is equilateral

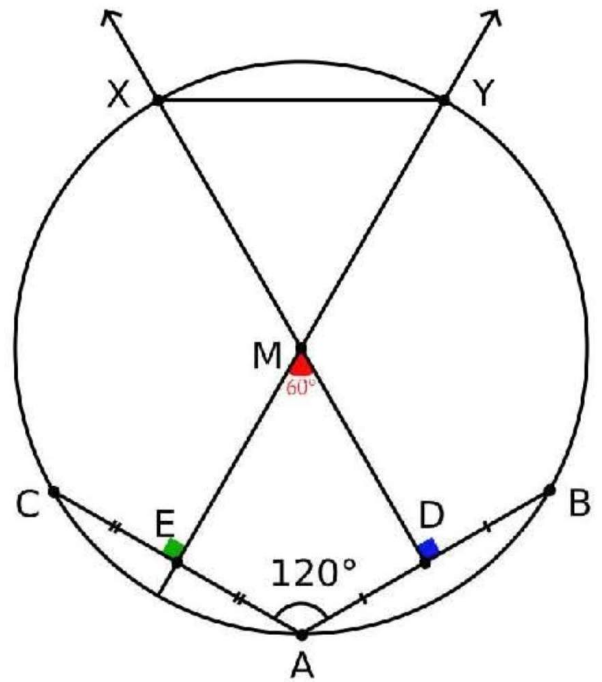

**Q5**

In the opposite figure:

Two concentric circles with ,

$\overline{AB}$  is a chord of the greater circle

and intersects the smaller circle at  $C$  and  $D$

and  $\overline{ME} \perp \overline{AB}$

- Prove that:  $AC = BD$

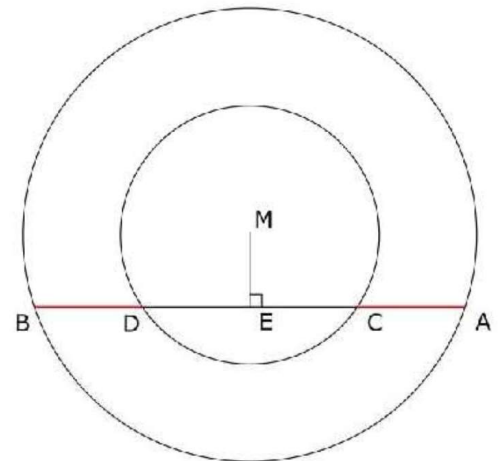

**Solution**

*In the small circle*

$\therefore ME \perp DC$

$\therefore E$  is midpoint of  $DC$

$CE = DE \implies (1)$

*In the big circle*

$\therefore ME \perp AB$

$\therefore E$  is midpoint of  $AB$

$AE = BE \implies (2)$

subtract (2) from (1)

$AC = BD$

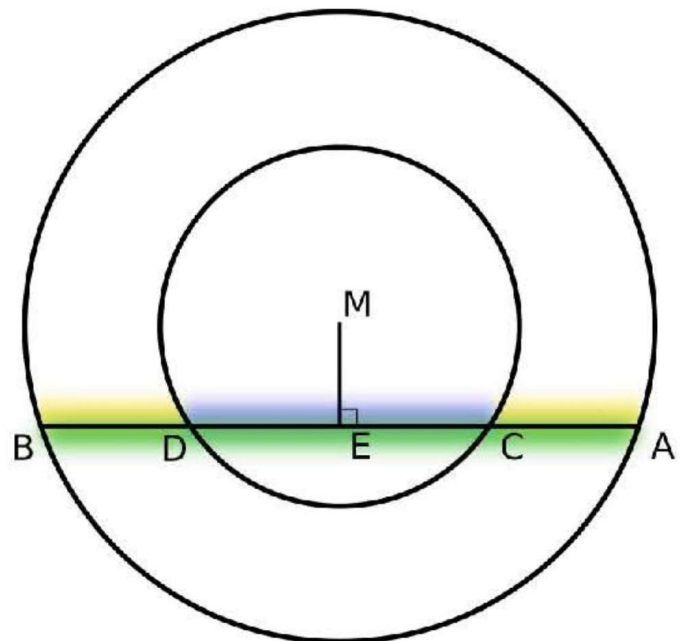

**Q6**

In the opposite figure:

$ABC$  is a triangle drawn inside a circle with centre  $M$

(inscribed triangle),  $\overline{MD} \perp \overline{BC}$  and  $\overline{ME} \perp \overline{AC}$

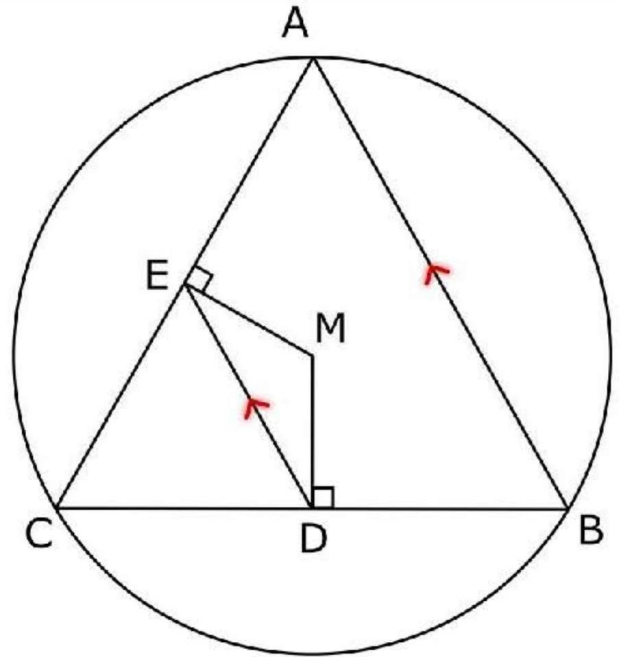

1. Prove that:  $\overline{ED} \parallel \overline{AB}$
2. Prove that:  
the perimeter of  $\Delta CDE$   
 $= \frac{1}{2}$  the perimeter of  $\Delta ABC$

**Solution**

$\therefore ME \perp AC$

$\therefore E$  is midpoint of  $AC$

$\therefore MD \perp BC$

$\therefore D$  is midpoint of  $BC$

In  $\Delta ABC$

$\therefore E$  is midpoint of  $AC$

$\therefore D$  is midpoint of  $BC$

$\therefore ED \parallel AB$

$$, ED = \frac{1}{2}AB \Rightarrow (1)$$

$$, EC = \frac{1}{2}AC \Rightarrow (2)$$

$$, CD = \frac{1}{2}CB \Rightarrow (3)$$

Adding (1), (2), (3)

$$\text{Perimeter of } \Delta CDE = \frac{1}{2} \text{ Perimeter of } \Delta ABC$$

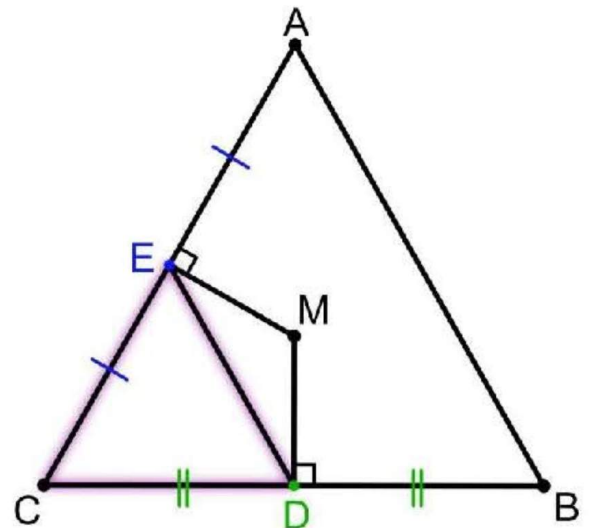

**Q7**

In the opposite figure:

In circle ,  $\overline{MX} \perp \overline{AB}$  ,  $\overline{MY} \perp \overline{AC}$   
 ,  $m(\angle A) = 60^\circ$  and  $m(\angle B) = 70^\circ$

- Find the measures of the interior angles of  $\Delta MXY$

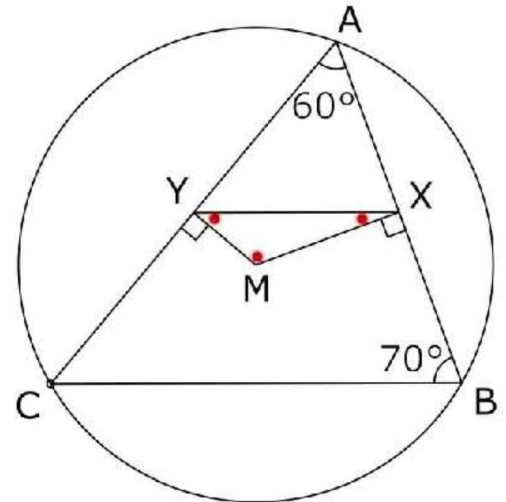

**Solution**

$m(\angle m) = 360 - (90 + 90 + 60) = 120^\circ$

In circle M

$\therefore MX \perp AB$

$\therefore X$  is midpoint of  $AB \implies (1)$

$\therefore MY \perp AC$

$\therefore Y$  is midpoint of  $AC \implies (2)$

from (1), (2)

$\therefore XY \parallel BC$

$\therefore m(\angle BXY) = 180 - 70 = 110^\circ \leftarrow$  interior

$m(\angle mxy) = 110 - 90 = 20^\circ$

In  $\Delta XMY$

$m(\angle MYX) = 180 - (20 + 120) = 40^\circ$

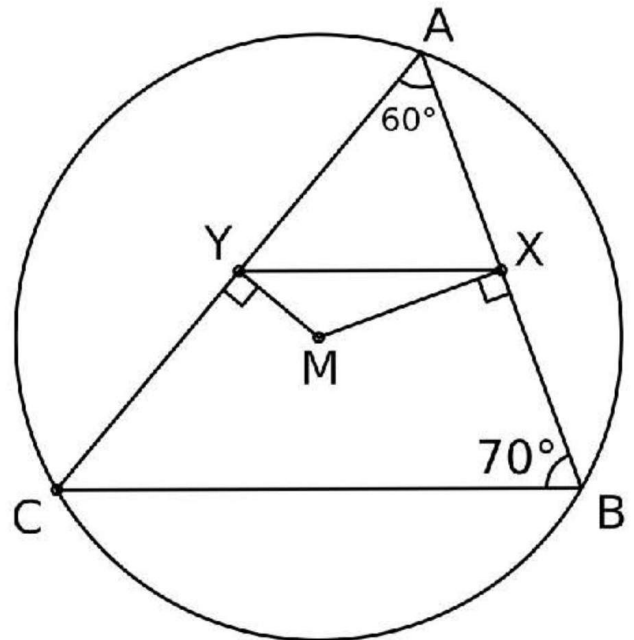

**Q8**

In the opposite figure:

$\overline{AB}$  is a chord of circle  $M$ ,

$\overrightarrow{AC}$  bisects  $\angle BAM$  and intersects circle  $M$  at  $C$

If  $D$  is the midpoint of  $\overline{AB}$

- Prove that:  $\overline{DM} \perp \overline{CM}$

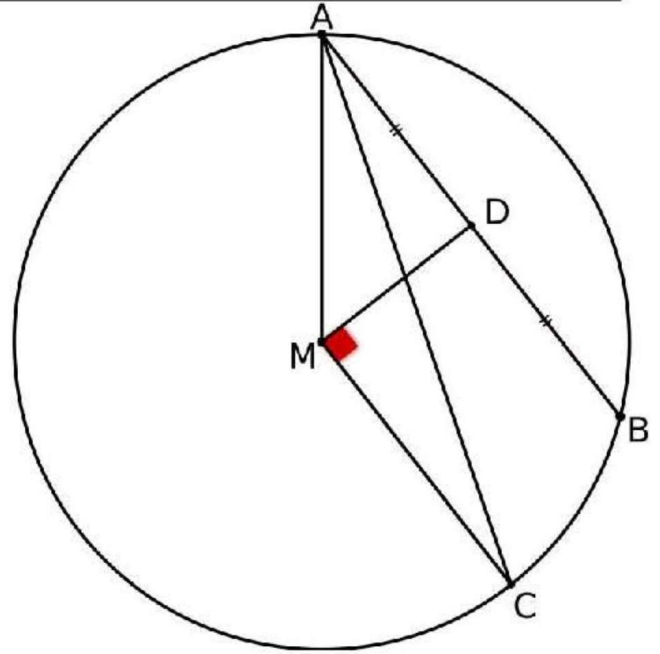

**Solution**

In  $\triangle AMC$   
 $\because MA = MC = r \implies \text{isosceles}$   
 $\therefore m(\angle MAC) = m(\angle MCA) \implies (1)$

$m(\angle MAC) = m(\angle DAC) \Leftarrow \text{Bisector} \implies (2)$

From (1), (2)  
 $m(\angle MCA) = m(\angle DAC) \implies \text{Alternate}$   
 $\therefore MC \parallel AB \implies (3)$

In circle  $M$   
 $\because D$  is midpoint of  $AB$   
 $\therefore MD \perp AB \implies (4)$

From (3), (4)

$MD \perp CM$

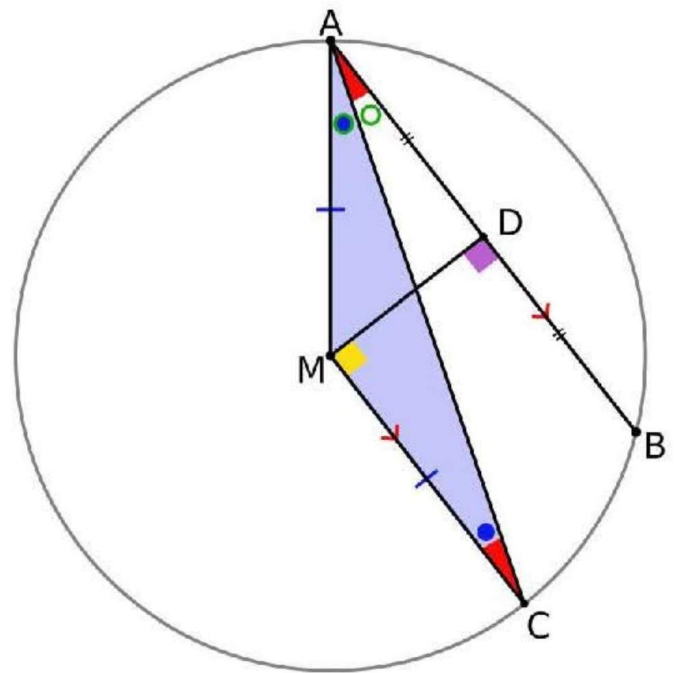

Unit 4 | Lesson 2

" Position of a point and a straight line with respect to a circle "

**Q1**

In the opposite figure

$M$  is a circle with radius length  $5\text{ cm}$ ,

$XY = 12\text{ cm}$ ,  $\overline{MY} \cap \text{circle } M = \{Z\}$

and  $ZY = 8\text{ cm}$

**Prove that:**  $\overleftrightarrow{XY}$  is a tangent to the circle  $M$

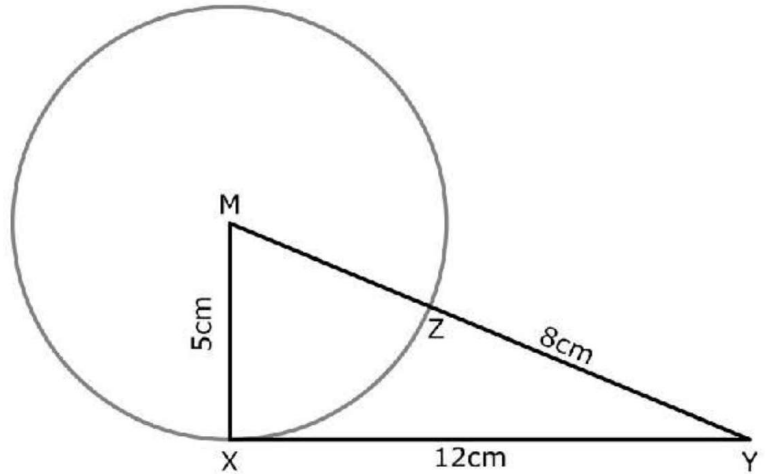

Solution

$MZ = MX = r = 5\text{ cm}$

$MY^2 = (8 + 5)^2 = 169\text{ cm}^2$

$MX^2 + XY^2 = 5^2 + 12^2 = 169\text{ cm}^2$

In  $\triangle MXY$

$\therefore MY^2 = MX^2 + XY^2$

$\therefore m(\angle MXY) = 90^\circ \Leftarrow \text{Pythagoras}$

In Circle  $M$

$\therefore MX \perp \overleftrightarrow{XY}$

$\therefore \overleftrightarrow{XY}$  tangent

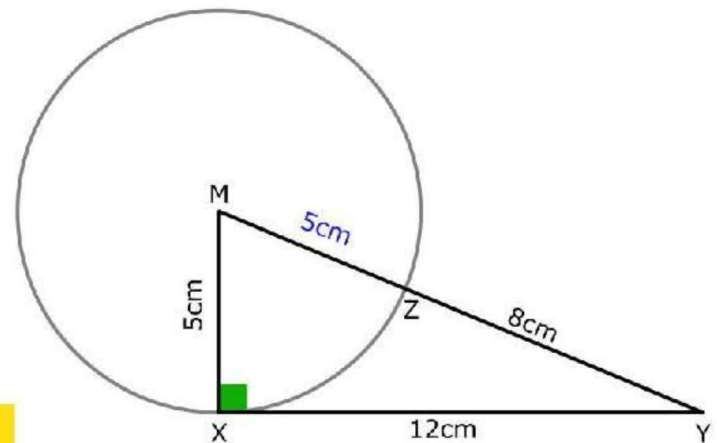

**Q2**

In the opposite figure:

$\overrightarrow{AB}$  is a tangent to the circle  $M$  at  $A$

$MA = 8 \text{ cm}$  ,  $m(\angle ABM) = 30^\circ$  and  $\overline{AC} \perp \overline{MB}$

**Find:** the length of each of  $\overline{AB}$  and  $\overline{AC}$

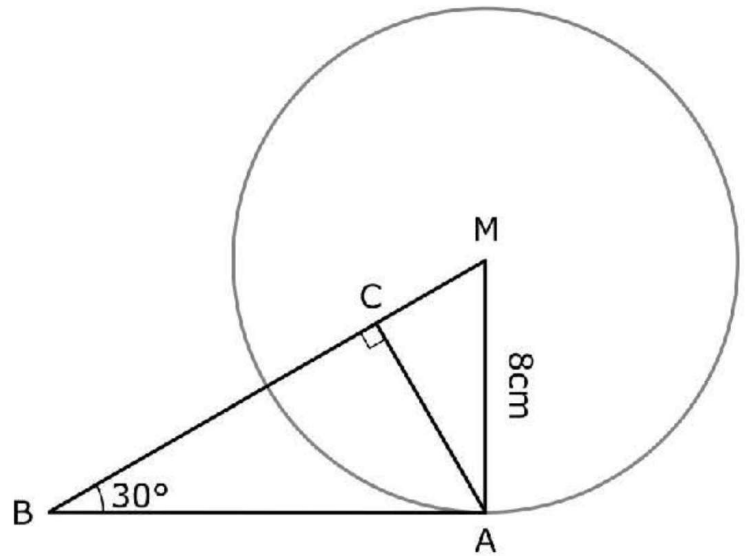

**Solution**

$\because \overrightarrow{AB}$  tangent  
 $\therefore \overrightarrow{AB} \perp \overline{AM}$

In  $\triangle ABM$   
 $\because m(\angle MAB) = 90^\circ$  ,  $m(\angle ABM) = 30^\circ$   
 $\therefore AM = \frac{1}{2}MB$   
 $\therefore MB = 8 \times 2 = 16 \text{ cm}$

$AB = \sqrt{16^2 + 8^2} = 8\sqrt{3} \text{ cm} \leftarrow \text{Pythagoras}$

$AC = \frac{AM \times AB}{MB} = \frac{8 \times 8\sqrt{3}}{16} = 4\sqrt{3} \leftarrow \text{Eclidean}$

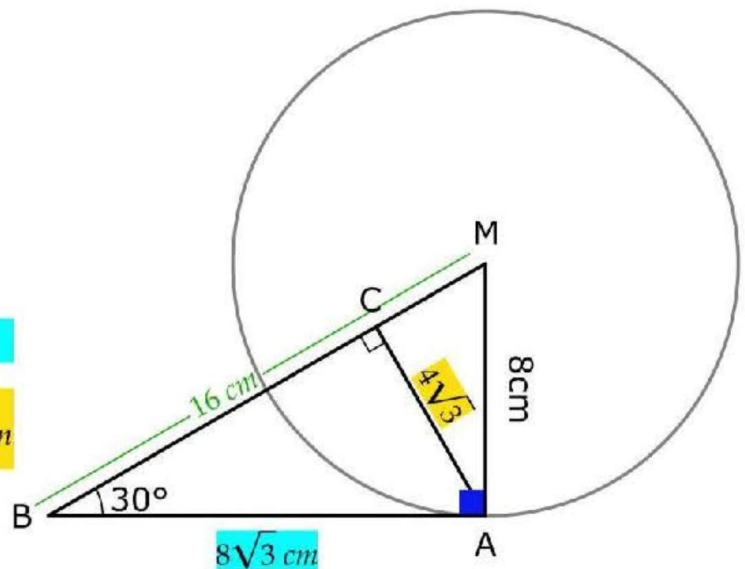

**Q3**

$\overline{AB}$  is a diameter in circle  $M$   $\overline{AC}$  and  $\overline{BD}$  are two tangents of the circle  $M$ ,  $\overline{CD}$  intersects the circle  $M$  at  $X$  and  $Y$  and intersects  $\overline{BD}$  at  $E$

**Prove that:**  $CX = YE$

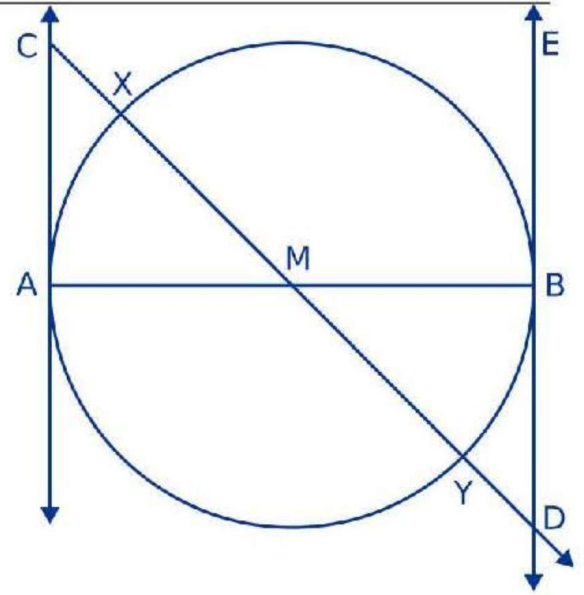

**Solution**

$\because \overline{BD}$  tangent  
 $\therefore m(\angle MBD) = 90^\circ$   
 $\because \overline{AC}$  tangent  
 $\therefore m(\angle MAC) = 90^\circ$

In  $\triangle AMC$  &  $\triangle BMD$   
 1-  $AM = BM = r$   
 2-  $m(\angle BMD) = m(\angle AMC) \leftarrow V. O. A$   
 3-  $m(\angle MBD) = m(\angle MAC)$   
 $\therefore \triangle AMC \cong \triangle BMD$   
 $\therefore \triangle AMC \cong \triangle BMD$   
 $\therefore MD = MC \Rightarrow (1)$   
 $\therefore XY = MY = r \Rightarrow (2)$

subtract (2) from (1)  
 $CX = DY$

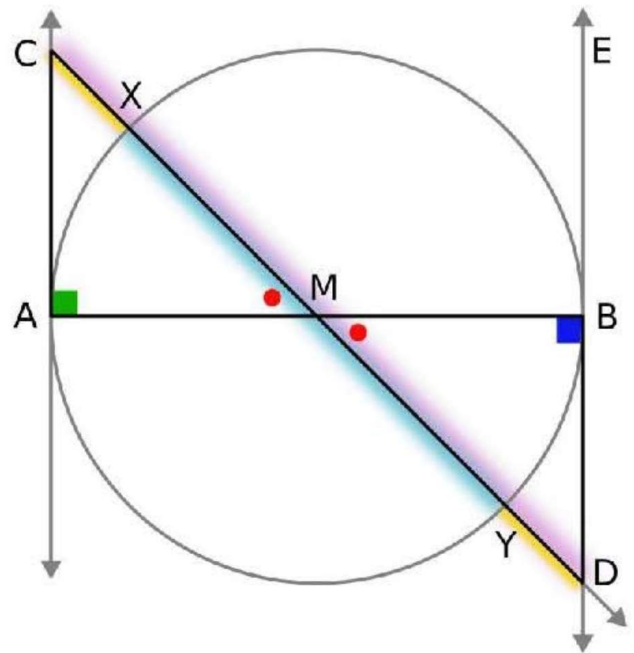

**Q4**

In the opposite figure:

$M$  circle with radius length of 5 cm ,  
 $A$  is a point outside the circle ,  
 $\overline{AD}$  is a tangent to the circle  $M$  at  $D$  ,  
 $\overline{AB}$  intersects the circle at  $B$  and  $C$   
 respectively where  $AB = 4$  cm  
 and  $AC = 12$  cm

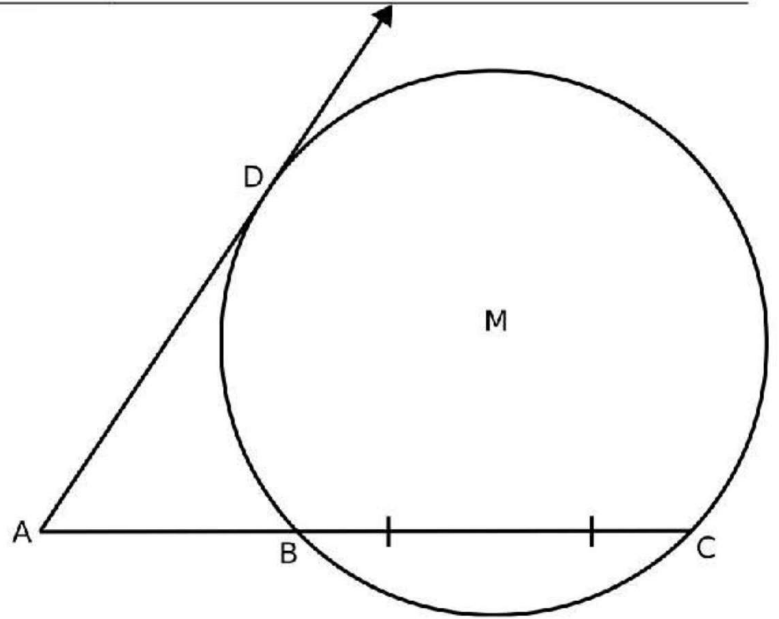

- Find the distance of the chord  $\overline{BC}$  from the center of the circle.
- Calculate the length of  $\overline{AD}$

**Solution**

Put  $X$  as midpoint of  $BC$   
 Draw  $MX$  ,  $CM$  ,  $AM$  and  $MD$

$BC = 12 - 4 = 8$  cm

$\therefore X$  midpoint of  $BC$   
 $\therefore MX \perp BC$   
 $\therefore BX = CX = 8 \div 2 = 4$  cm

$MC = r = 5$  cm  
 $MD = r = 5$  cm

In  $\triangle CXM$   
 $MX = \sqrt{5^2 - 4^2} = 3$  cm  $\leftarrow$  Pythagoras

The distance of the chord  $BC$  from the centre of the circle =  $MX = 3$  cm

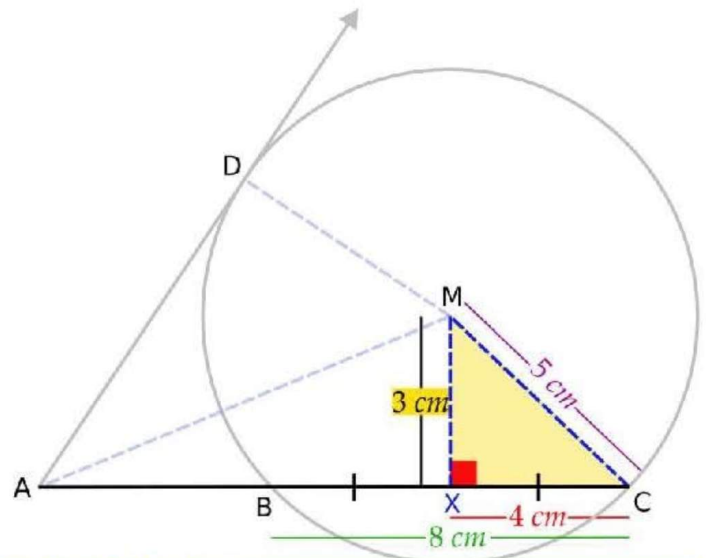

$\therefore \overrightarrow{DA}$  tangent  
 $\therefore MD \perp AD$

In  $\triangle AMX$   
 $AX = 4 + 4 = 8 \text{ cm}$   
 $AM = \sqrt{8^2 + 3^2} = \sqrt{73} \text{ cm} \leftarrow \text{Pythagoras}$

In  $\triangle ADM$   
 $AD = \sqrt{73 - 25} = 4\sqrt{3} \text{ cm} \leftarrow \text{Pythagoras}$

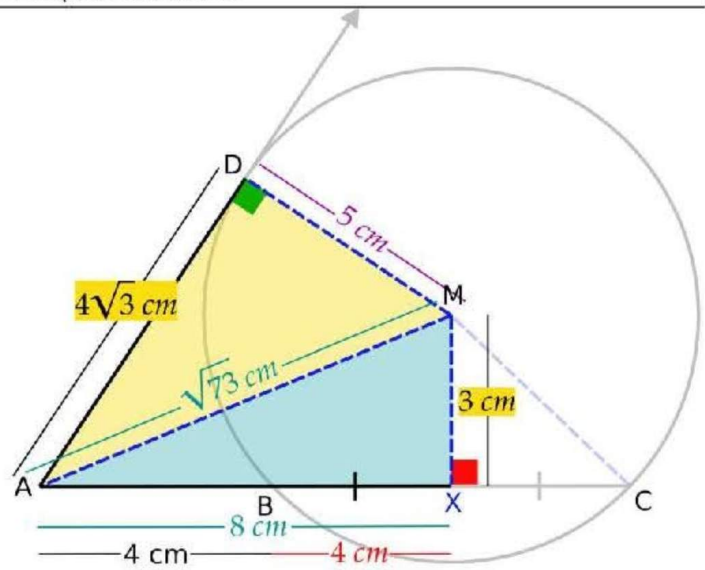

**Q5**

If  $\overline{CD}$  is a diameter of the circle  $M$  where  $M(1,1)$ ,  $D(3,-2)$

**Find:** the equation of the tangent to  $M$  at  $C$

**Solution**

Let  $\{A\} \in$  the tangent to the circle  $M$  at  $C$

$$\text{Slop of } \overline{CD} = \frac{-2-1}{3-1} = \frac{-3}{2}$$

$\therefore \overleftrightarrow{AC}$  tangent

$\therefore \overleftrightarrow{AC} \perp \overline{CD}$

$$\therefore \text{Slop of } \overleftrightarrow{AC} = \frac{2}{3}$$

$\therefore M$  midpoint of  $\overline{CD}$

$$\therefore C = (1 \times 2 - 3, 1 \times 2 + 2) = (-1, 4)$$

$$y = mx + c$$

$$4 = \frac{2}{3} \times (-1) + c \implies c = 4\frac{2}{3}$$

the equation of the tangent is:  $y = \frac{2}{3}x + 4\frac{2}{3}$

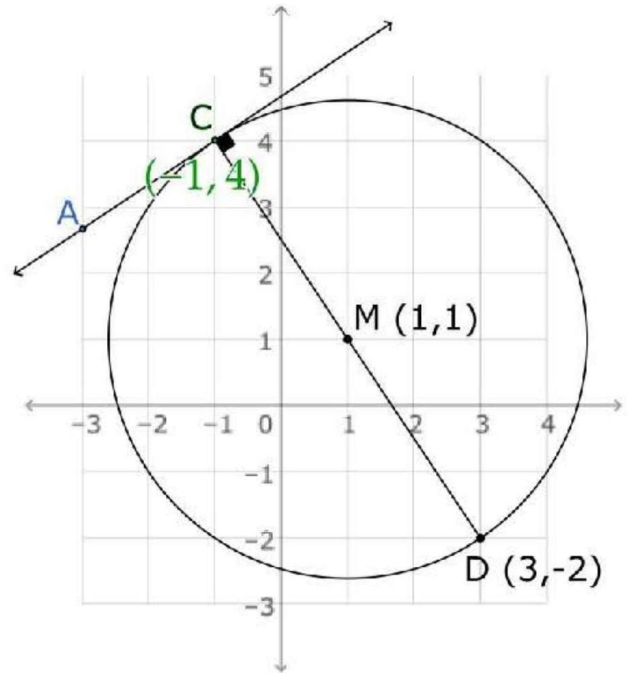

**Unit 4 | Lesson 3**  
**" Position of a circle with respect to another circle "**

**Q1**

In the opposite figure:

$M$  and  $N$  are two circles with radii lengths of  $10\text{ cm}$  and  $6\text{ cm}$  respectively and they are touching internally at  $A$ ,  $\overline{AB}$  is a common tangent for both. If the area of  $\triangle BMN = 24\text{ cm}^2$

Find: *the length of  $\overline{AB}$*

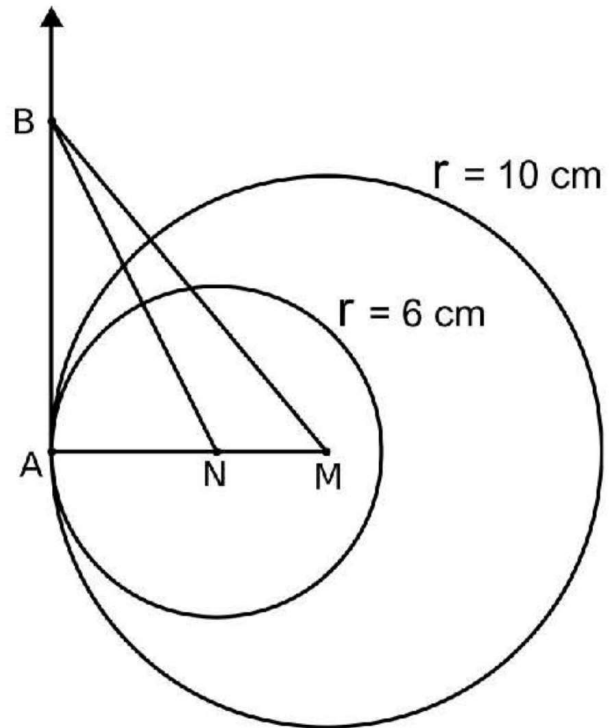

**Solution**

$MN = 10 - 6 = 4\text{ cm}$

Area of  $\triangle BMN = \frac{1}{2} \times MN \times AB$

$\therefore \frac{1}{2} \times 4 \times AB = 24\text{ cm}^2$

$AB = 12\text{ cm}$

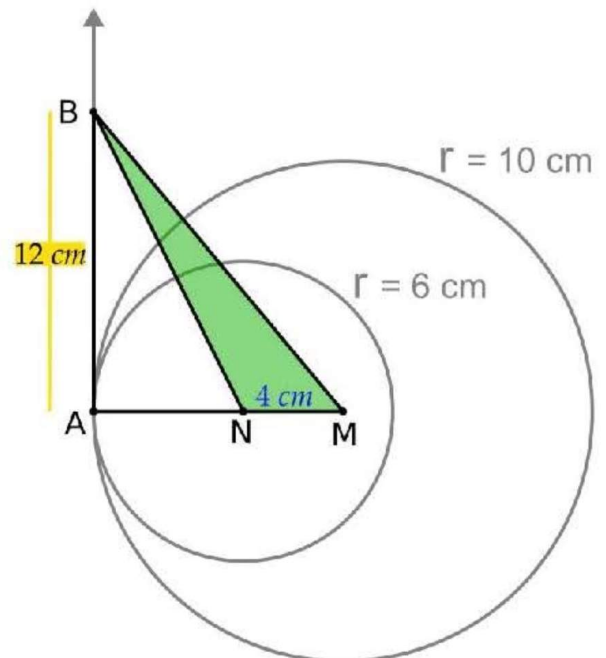

**Q2**

In the opposite figure:

$M$  and  $N$  are two intersecting circles at  $A$  and  $B$ ,  $C \in \overrightarrow{BA}$ ,  $D \in$  the circle  $N$ ,  $m(\angle MND) = 125^\circ$  and  $m(\angle BCD) = 55^\circ$

**Prove that:**  $\overleftrightarrow{CD}$  is a tangent to the circle  $N$  at  $D$

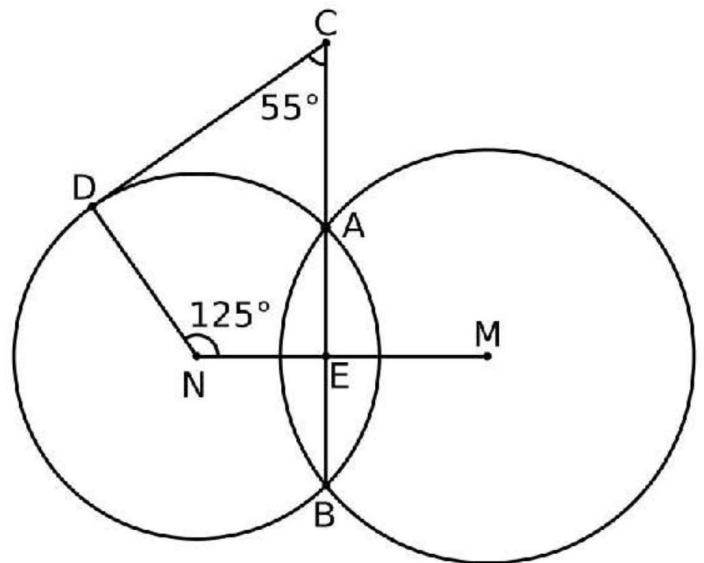

**Solution**

$\because \overline{AB}$  common chord  
 $\therefore \overline{AB} \perp \overline{MN}$

In quadrilateral  $ENDC$   
 $m(\angle NDC) = 360 - (125 + 90 + 55) = 90^\circ$

In circle  $N$   
 $\therefore \overleftrightarrow{CD} \perp \overleftrightarrow{ND}$   
 $\therefore \overleftrightarrow{CD}$  tangent

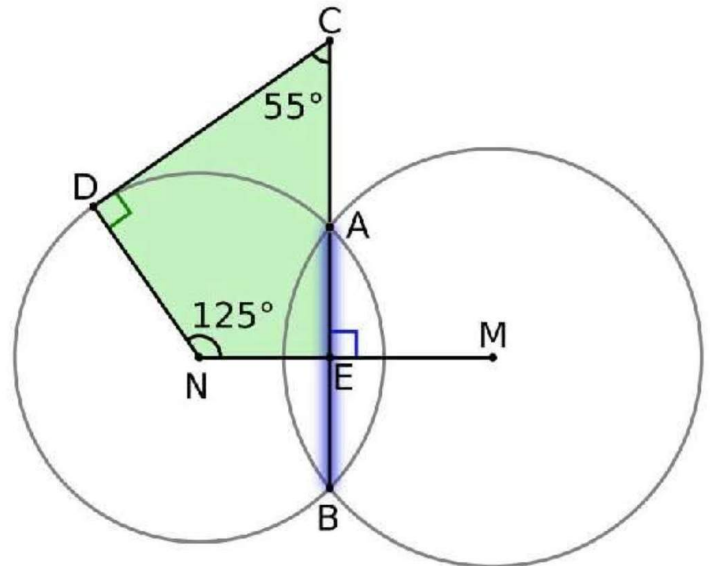

**Q3**

$M$  and  $N$  are two intersecting circles at  $A$  and  $B$ ,  $MA = 12\text{ cm}$ ,  $NA = 9\text{ cm}$  and  $MN = 15\text{ cm}$

**Find:** the length of  $\overline{AB}$

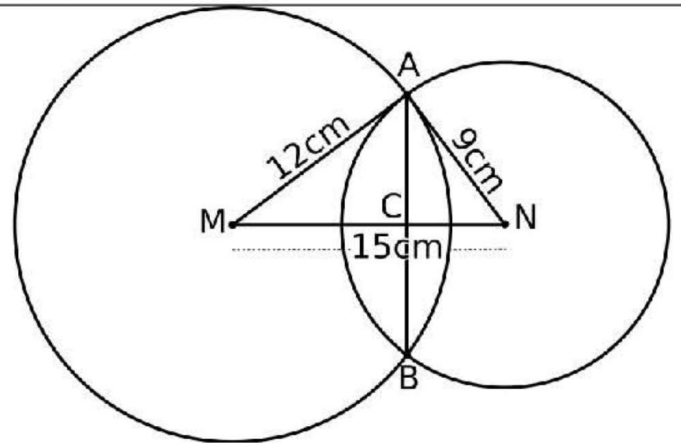

**Solution**

Let  $\overline{AB} \cap \overline{MN} = \{C\}$

$\therefore \overline{AB}$  common chord

$\therefore \overline{AB} \perp \overline{MN}$ ,  $C$  midpoint of  $\overline{AB}$

In  $\triangle AMN$

$$(MN)^2 = 225$$

$$(AM)^2 + (AN)^2 = 225$$

$$\therefore (MN)^2 = (AM)^2 + (AN)^2$$

$$\therefore m(\angle MAN) = 90^\circ$$

$\therefore \overline{AC} \perp \overline{MN}$

$$\therefore AC = \frac{AM \times AN}{MN} = \frac{12 \times 9}{15} = 7.2\text{ cm}$$

$$AB = 7.2 \times 2 = 14.4\text{ cm}$$

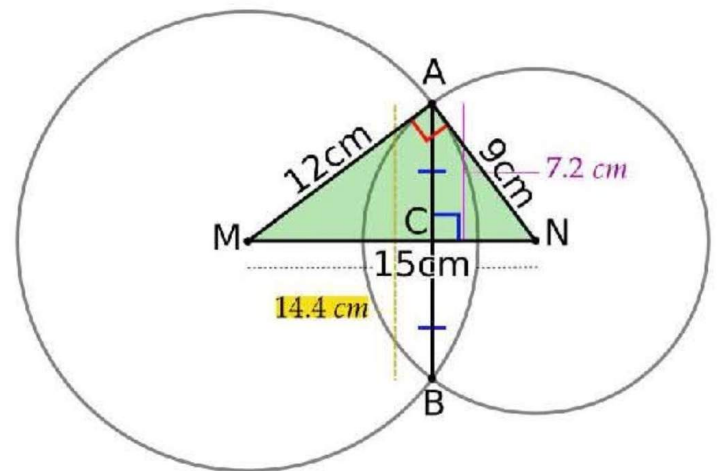

**Q4**

In the opposite figure:

$M$  and  $N$  are two intersecting circles at  $A$  and  $B$ ,  $\overline{CD}$  is a diameter in the circle  $M$ ,  $\overline{CX}$  is a tangent to the circle  $M$  at  $C$  where  $\overline{CX} \cap \overline{BA} = \{F\}$

**Prove that:**  $m(\angle DMN) = m(\angle CEB)$

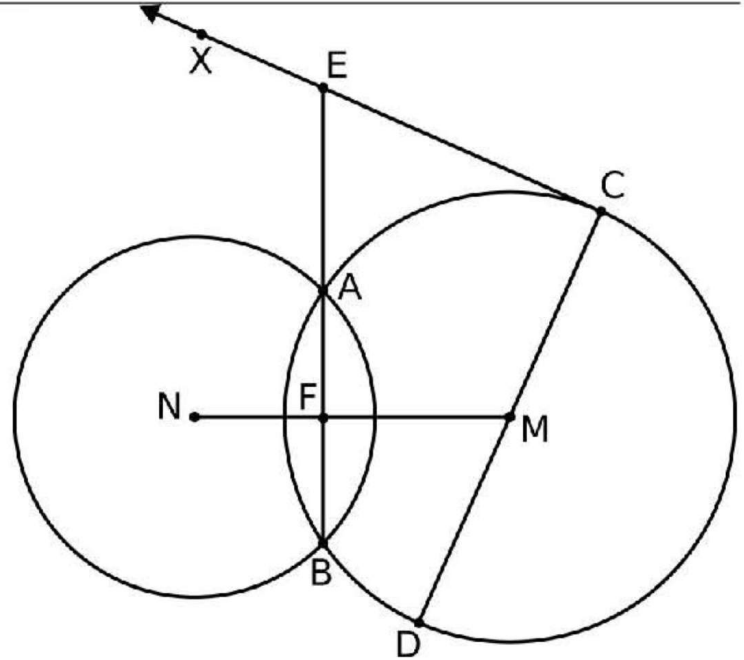

**Solution**

$\because \overline{AB}$  common chord  
 $\therefore \overline{AB} \perp \overline{MN}$

$\because \overline{CX}$  tangent  
 $\therefore \overline{MC} \perp \overline{XC}$

In quadrilateral  $ECMF$   
 $\therefore$  sum of all interior angles =  $360^\circ$   
 $\therefore m(\angle CMF) + m(\angle CEB) + 90 + 90 = 360^\circ$   
 $\therefore m(\angle CMF) + m(\angle CEB) = 180^\circ \implies (1)$

$m(\angle CMF) + m(\angle DMN) = 180^\circ \leftarrow$  straight line  $\implies (2)$

from (1),(2)  
 $m(\angle CEB) = m(\angle DMN)$

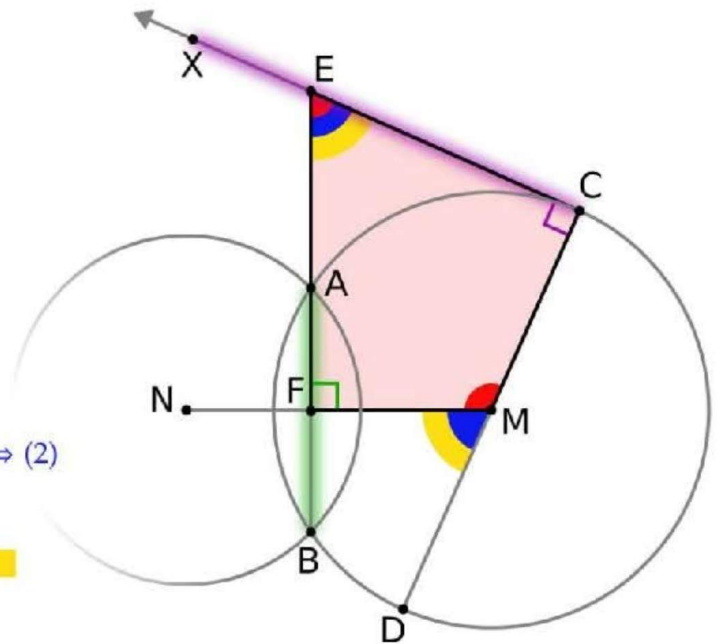

**Unit 4 | Lesson 5**  
**" The relation between the chords of a circle and its center "**

**Q1**

In the opposite figure

$\overline{AB}, \overline{AC}$  are two chords equal in length in the circle  $M$ ,

$X$  is the midpoint of  $\overline{AB}$ ,

$Y$  is the midpoint of  $\overline{AC}$  and  $m(\angle CAB) = 70^\circ$

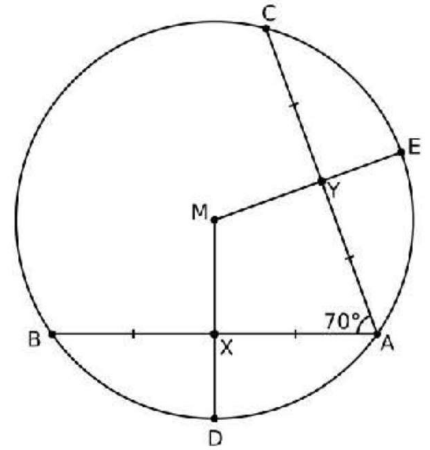

1. Calculate:  $m(\angle DME)$
2. Prove that:  $XD = YE$

**Solution**

$\because X$  midpoint of  $\overline{AB}$   
 $\therefore \overline{MX} \perp \overline{AB}$

$\because Y$  midpoint of  $\overline{AC}$   
 $\therefore \overline{MY} \perp \overline{AC}$

In quadrilateral  $AYMX$   
 $m(\angle DME) = 360 - (90 + 90 + 70) = 110^\circ$

$\because AB = AC \implies$  chords equal  
 $\therefore MX = MY \leftarrow$  distance equal  $\implies (1)$

$MD = ME = r \implies (2)$

Subtract (1) from (2)  
 $XD = YE$

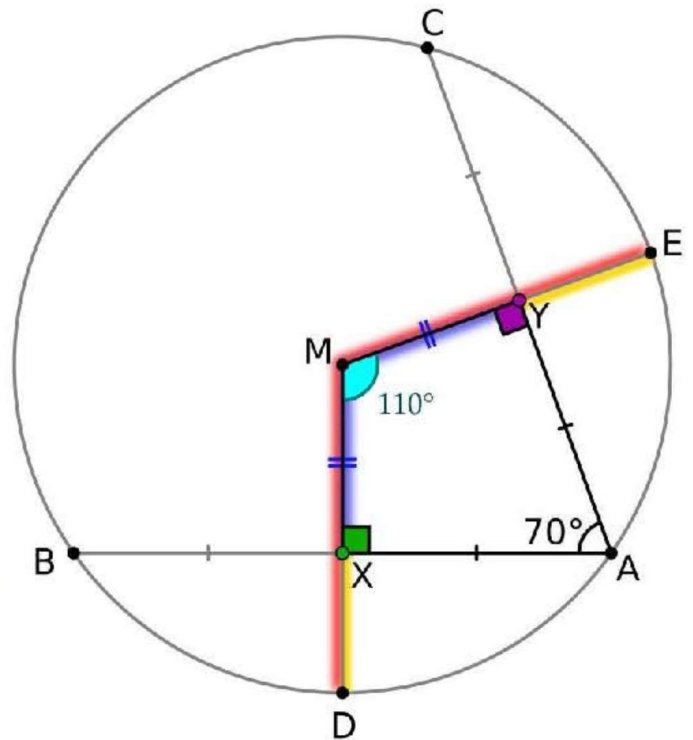

**Q2**

In the opposite figure:

$\overline{AB}$  and  $\overline{AC}$  are two chords equal in length  
in the circle  $M$ ,  $X$  is the midpoint of  $\overline{AB}$ ,

$\overline{MX}$  intersect the circle at  $D$ ,  $\overline{MY} \perp \overline{AC}$

intersect it at  $Y$  and intersect the circle at  $E$

Prove that:

1.  $XD = YE$
2.  $m(\angle YXB) = m(\angle XYC)$

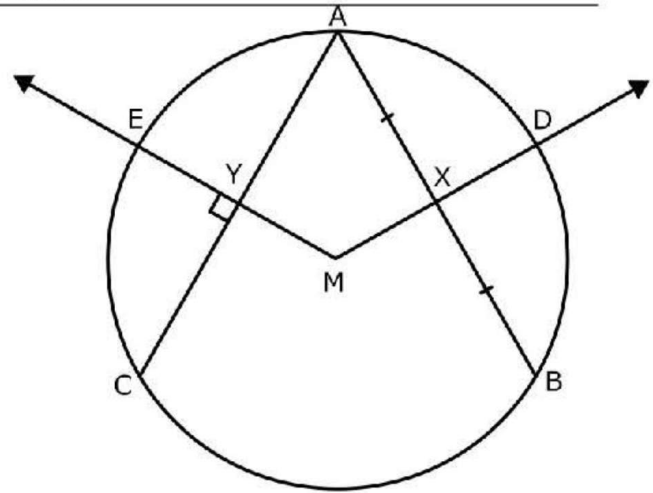

**Solution**

$\because X$  midpoint of  $\overline{AB}$   
 $\therefore \overline{MX} \perp \overline{AB}$

$\because \overline{MY} \perp \overline{AC}$   
 $\therefore Y$  midpoint of  $\overline{AC}$

$\because AB = AC \implies$  chords equal  
 $\therefore MX = MY \leftarrow$  distance equal  $\implies$  (1)

$MD = ME = r \implies$  (2)

Subtract (1) from (2)  
 $XD = YE$

$m(\angle MXB) = m(\angle MYC) = 90^\circ \implies$  (3)

In  $\triangle MXY$   
 $m(\angle MXY) = m(\angle MYX) \leftarrow$  isosceles  $\implies$  (4)

Add (3) to (4)  
 $m(\angle YXB) = m(\angle XYC)$

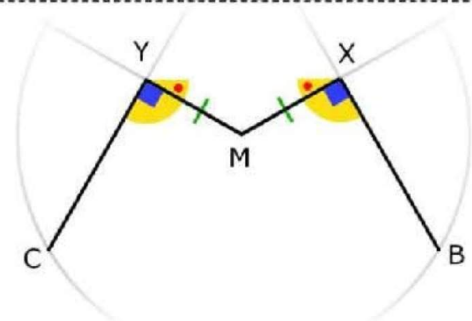
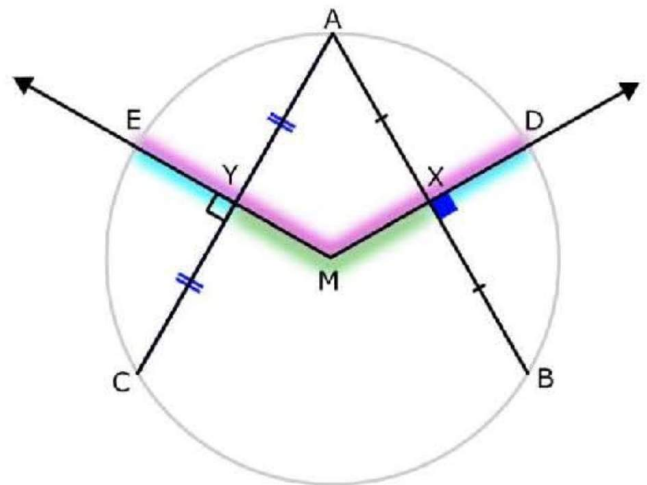

**Q3**

$\overline{AB}$  and  $\overline{AC}$  are two chords in the circle  $M$ ,  $\overline{MX} \perp \overline{AB}$ ,  $Y$  is midpoint of  $\overline{AC}$ ,  $m(\angle ABC) = 75^\circ$ ,  $MX = MY$

1. Find:  $m(\angle BAC)$

2. Prove that:

the perimeter of  $\triangle AXY = \frac{1}{2}$  the perimeter of  $\triangle ABC$

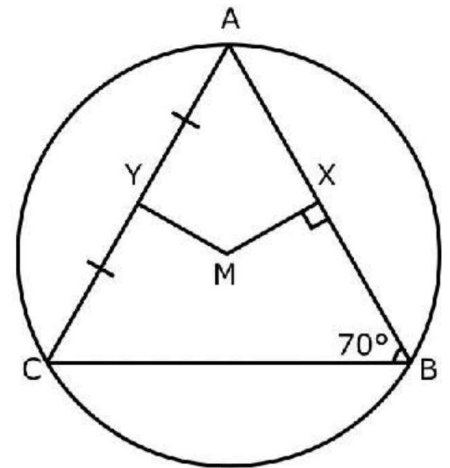

**Solution**

$\therefore \overline{MX} \perp \overline{AB}$

$\therefore X$  midpoint of  $\overline{AB}$

$\therefore Y$  midpoint of  $\overline{AC}$

$\therefore \overline{MY} \perp \overline{AC}$

$\therefore MX = MY \iff$  distance equal

$\therefore AB = AC \implies$  chords equal

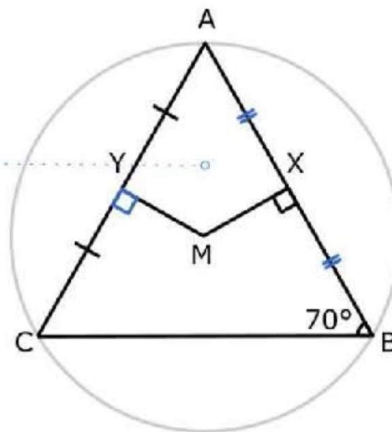

In  $\triangle ABC$

$m(\angle C) = m(\angle B) = 70^\circ \iff$  isoseles

$m(\angle A) = 180 - (70 + 70) = 40^\circ$

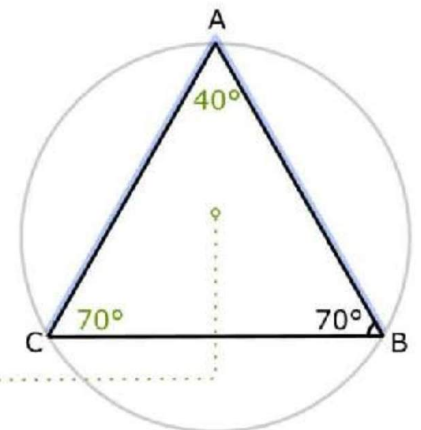

$\therefore X$  midpoint of  $\overline{AB}$ ,  $Y$  midpoint of  $\overline{AC}$

$\therefore XY = \frac{1}{2}BC$

$\therefore AX = \frac{1}{2}AB$ ,  $AY = \frac{1}{2}AC$

Perimeter of  $\triangle ABC = AB + BC + AC$

$= 2AX + 2XY + 2AY = 2$ Perimeter of  $\triangle AXY$

$\therefore$  Perimeter of  $\triangle AXY = \frac{1}{2}$ Perimeter of  $\triangle ABC$

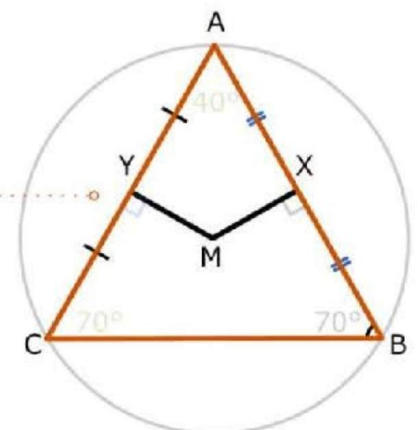

**Q4**

In the opposite figure:

$\overline{AB}$  and  $\overline{CD}$  are two chords of the circle  $M$

,  $\overline{MX} \perp \overline{AB}$  and intersects the circle at  $F$

,  $\overline{MY} \perp \overline{CD}$  and intersects the circle at  $E$

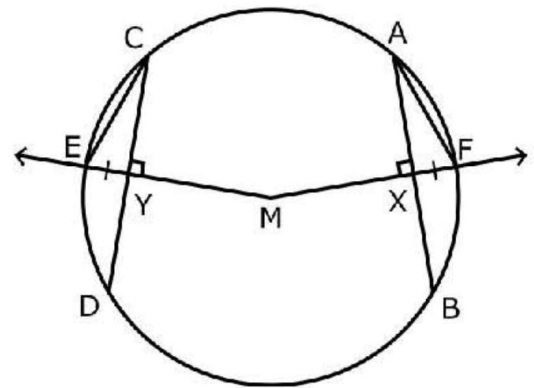

**Prove that:**

1.  $AB = CD$
2.  $AF = CE$

**Solution**

$\therefore MF = ME = r, XF = YE$

by subtracting

$\therefore MX = MY \implies \text{distance equal}$

$\therefore \overline{AB} = \overline{CD} \iff \text{chords equal}$

$\therefore \overline{MX} \perp \overline{AB}$

$\therefore X \text{ midpoint of } \overline{AB} \implies AX = \frac{1}{2}AB$

$\therefore \overline{MY} \perp \overline{CD}$

$\therefore Y \text{ midpoint of } \overline{CD} \implies CY = \frac{1}{2}CD$

$\therefore AB = CD$

$\therefore AX = CY$

In  $\triangle AXF, \triangle CYE$

(1)  $AX = CY$

(2)  $XF = YE$

(3)  $m(\angle AXF) = m(\angle CYE) = 90^\circ$

$\therefore \triangle AXF \cong \triangle CYE \text{ (S. A. S)}$

$\therefore \overline{AF} = \overline{CE}$

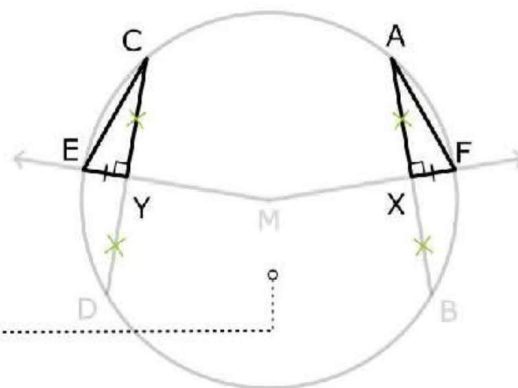
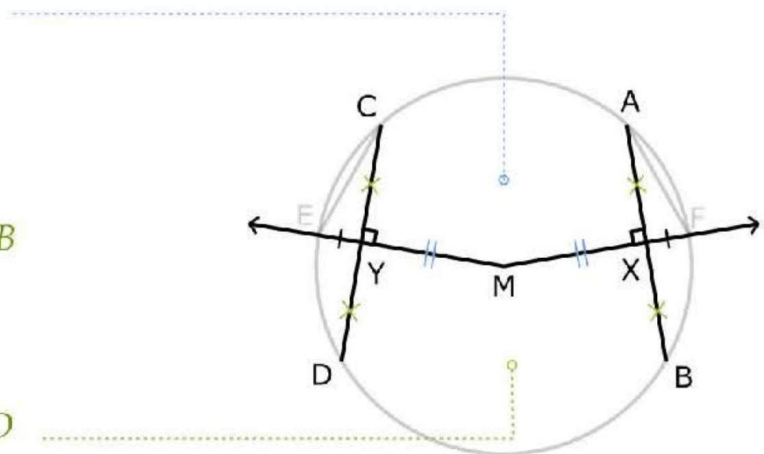

**Q5**

**In the opposite Figure:**

The circle  $M \cap$  The circle  $N = \{A, B\}$ ,  $\overleftrightarrow{AB} \cap \overleftrightarrow{MN} = \{C\}$   
 $, D \in \overleftrightarrow{MN}, \overline{MX} \perp \overline{BD}$

Prove that:  $MX = MY$

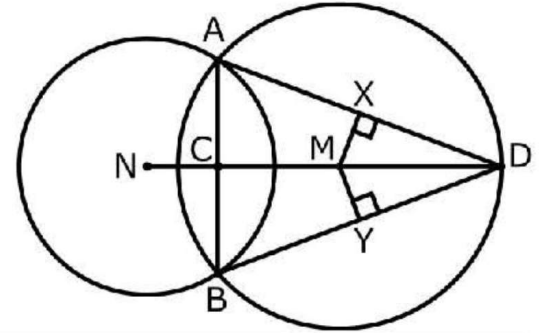

**Solution**

$\because \overline{AB}$  common chord  
 $\therefore \overline{CD} \perp \overline{AB}$  & C midpoint of  $\overline{AB}$

In  $\triangle ACD, \triangle BCD$   
 (1)  $\overline{CD}$  common side  
 (2)  $AC = BC$   
 (3)  $m(\angle ACD) = m(\angle BCD) = 90^\circ$   
 $\triangle ACD \cong \triangle BCD$  (S. A. S)

$\therefore \overline{AD} = \overline{BD} \implies$  chords equal  
 $\therefore MX = MY \leftarrow$  distance equal

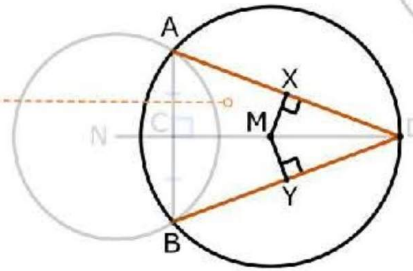
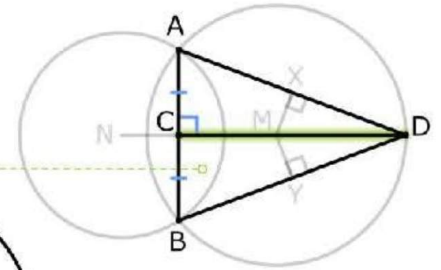
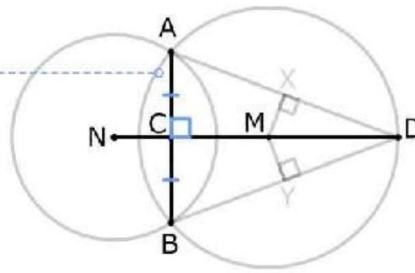

**Q7**

In the opposite figure:

The concentric circles of radii length 4 cm , 2 cm.  $\Delta ABC$  is drawn Such that its vertices lie on the greater circle and its sides touch the smaller circle at  $X, Y, Z$

- **Prove that**  $\Delta ABC$  is an equilateral triangle
- **Find** the area of  $\Delta ABC$

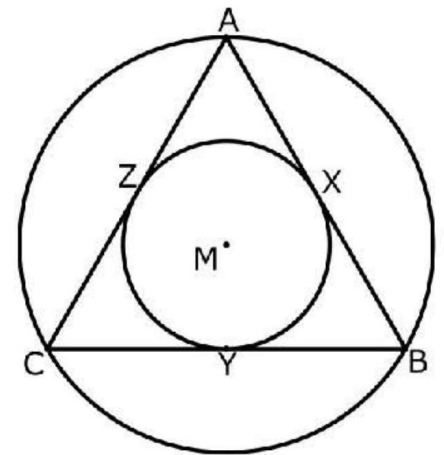

**Solution**

In small circle

$\because \overline{AB}, \overline{BC}, \overline{AC}$  tangents  
 $\therefore \overline{AB} \perp \overline{MX}, \overline{BC} \perp \overline{MY}, \overline{AC} \perp \overline{MZ}$   
 $MX = MY = MZ = 2 \text{ cm}$

In great circle

$\because MX = MY = MZ \implies$  distance equal  
 $\therefore \overline{AB} = \overline{BC} = \overline{CD} \leftarrow$  chords equal  
 $\therefore \Delta ABC$  is an equilateral triangle

$\because \overline{AB} \perp \overline{MX}$   
 $\therefore X$  midpoint of  $\overline{AB}$   
 $\because \overline{BC} \perp \overline{MY}$   
 $\therefore Y$  midpoint of  $\overline{BC}$   
 $\because \overline{AC} \perp \overline{MZ}$   
 $\therefore Z$  midpoint of  $\overline{AC}$

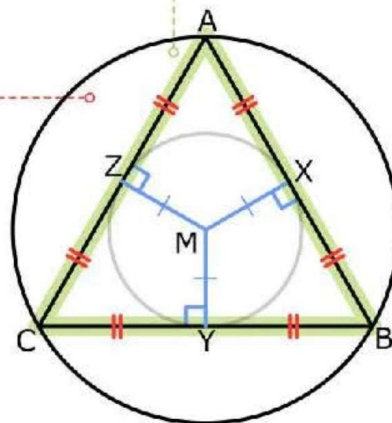
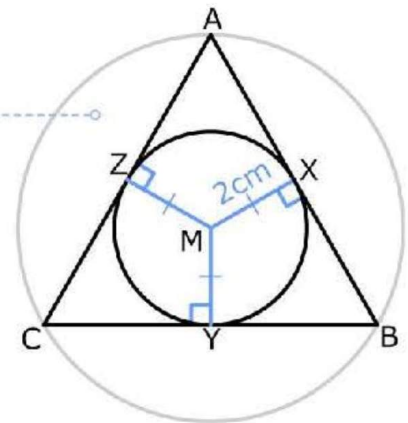

In  $\triangle AMX$

$$AX = \sqrt{(AM)^2 - (MX)^2} = \sqrt{4^2 - 2^2} = 2\sqrt{3} \text{ cm} \leftarrow \text{Pythagoras}$$

$$AB = 2 \times 2\sqrt{3} = 4\sqrt{3} \text{ cm}$$

$$AB = BC = CA = 4\sqrt{3} \text{ cm} \leftarrow \text{equilateral triangle}$$

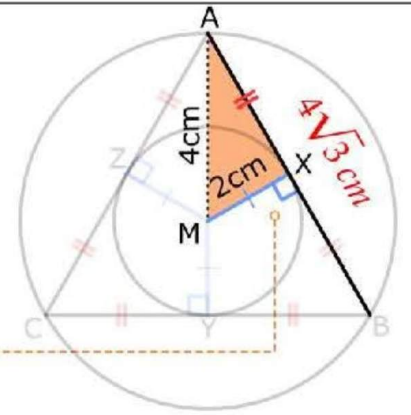

$$\text{Area of } \triangle AMB = \frac{1}{2} \times AB \times MX = \frac{1}{2} \times 4\sqrt{3} \times 2 = 4\sqrt{3} \text{ cm}^2$$

$$\text{Area of } \triangle BMC = \frac{1}{2} \times BC \times MY = \frac{1}{2} \times 4\sqrt{3} \times 2 = 4\sqrt{3} \text{ cm}^2$$

$$\text{Area of } \triangle AMC = \frac{1}{2} \times AC \times MZ = \frac{1}{2} \times 4\sqrt{3} \times 2 = 4\sqrt{3} \text{ cm}^2$$

$$\text{Area of } \triangle ABC = 4\sqrt{3} + 4\sqrt{3} + 4\sqrt{3} = 12\sqrt{3} \text{ cm}^2$$

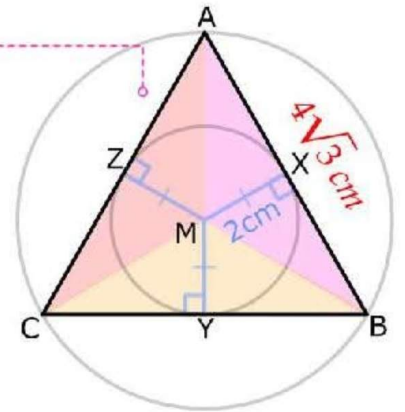

**Q8**

In the opposite figure:

$M$  and  $N$  are two congruent circles,  $\overleftrightarrow{AB} \parallel \overleftrightarrow{MN}$  and intersect circle  $M$  at  $A$  and  $B$  and intersects the circle  $N$  at  $C$  and  $D$

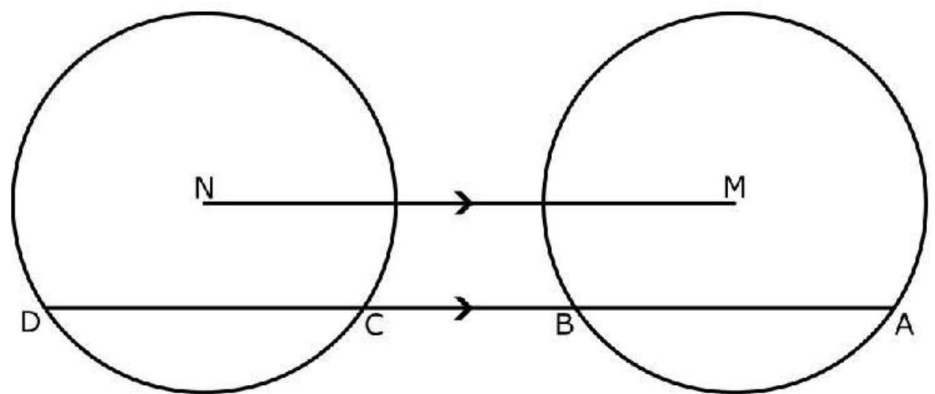

**Prove that:**  $AC = BD$

**Solution**

Let  $X$  is the midpoint of  $\overline{AB}$   
 Let  $Y$  is the midpoint of  $\overline{DC}$

In circle  $M$   
 $\therefore X$  midpoint of  $\overline{AB}$   
 $\therefore \overline{MX} \perp \overline{AB}$

In circle  $N$   
 $\therefore Y$  midpoint of  $\overline{DC}$   
 $\therefore \overline{MY} \perp \overline{DC}$

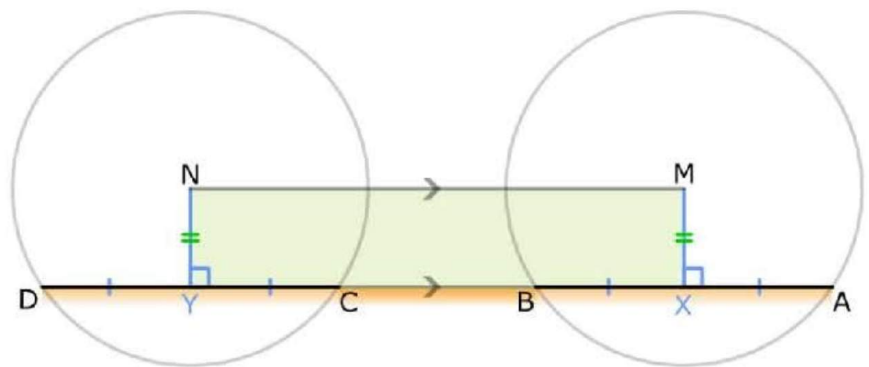

$\therefore \overline{MX} \perp \overline{AB}$ ,  $\overline{MY} \perp \overline{DC}$ ,  $\overline{MN} \parallel \overline{XY}$   
 $\therefore MNYX$  is rectangle  
 $\therefore MX = MY$

$\therefore M$  and  $N$  are two congruent circles  
 $\therefore MX = MY \implies$  distance equal  
 $\therefore AB = CD \iff$  chords equal

By adding the length of  $BC$   
 $AB + BC = CD + BC$   
 $AC = BD$

**Q9**

In the opposite figure:

$M, N$  are two congruent and distant circles,  $E$  is the midpoint of  $\overline{MN}$ ,  $\overleftrightarrow{AE}$  is drawn to cut the circle  $M$  at  $A$  &  $B$  and to cut the circle  $N$  at  $C, D$

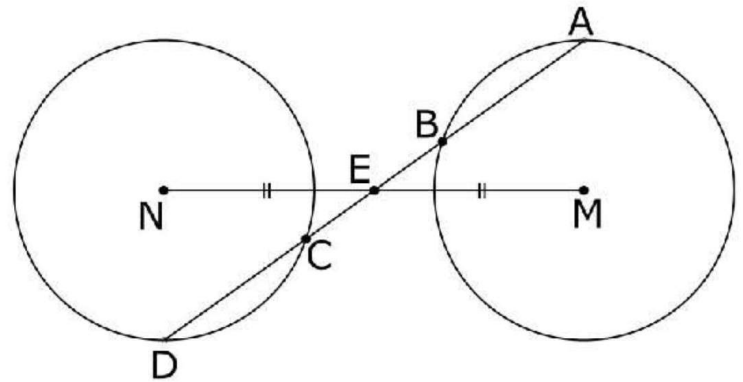

**Prove that:**

- $AB = CD$
- $E$  is the midpoint of  $\overline{AD}$

**Solution**

In circle  $M$

Let  $X$  midpoint of  $\overline{AB}$   
 $\therefore \overline{MX} \perp \overline{AB}$

In circle  $N$

Let  $Y$  midpoint of  $\overline{CD}$   
 $\therefore \overline{NY} \perp \overline{CD}$

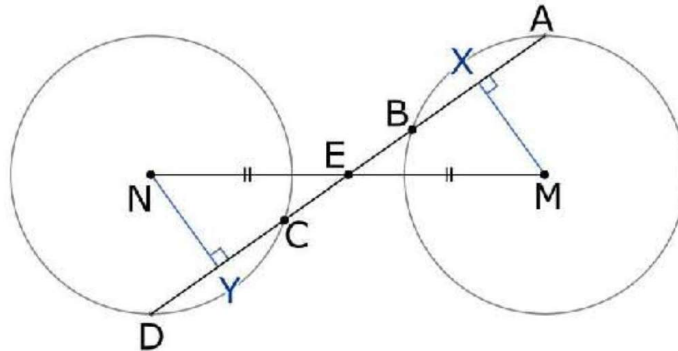

In  $\triangle MXE, \triangle NYE$  -

- 1  $\rightarrow ME = NE$
  - 2  $\rightarrow m(\angle MXE) = m(\angle NYE) = 90^\circ$
  - 3  $\rightarrow m(\angle MEX) = m(\angle NEY) \leftarrow (V.O.A)$
- $\therefore \triangle MXE \cong \triangle NYE$

$\therefore M, N$  are two congruent circles  
 $\therefore MX = NY \leftarrow (congruent) \Rightarrow$  distance equal  
 $\therefore AB = CD \leftarrow$  chords equal

$\therefore AX = \frac{1}{2}AB, DY = \frac{1}{2}DC, AB = CD$

$\therefore AX = DY \Rightarrow$  (1)

$EX = EY \leftarrow (congruent) \Rightarrow$  (2)

By adding (1), (2)

$AX + EX = DY + EY$

$\therefore AE = DE$

$\therefore E$  midpoint of  $\overline{AD}$

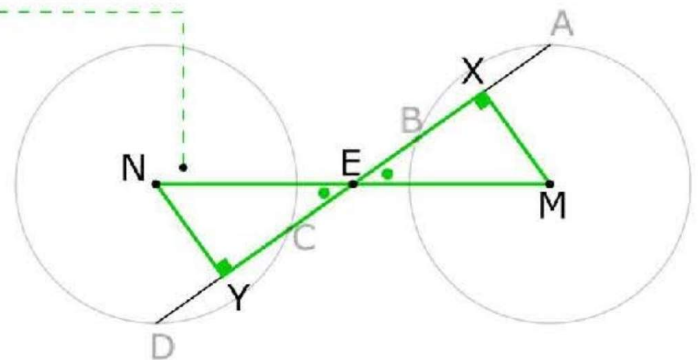

## Unit 5 | Lesson 1

### Central angles and measuring arcs

**Q1:**

In the opposite figure :

$ABCD$  is a quadrilateral inscribed in a circle  $M$ ,  $AC$  is a diameter in the circle,  $CB = CD$

Prove that:

$$\circ m(\widehat{AB}) = m(\widehat{AD})$$

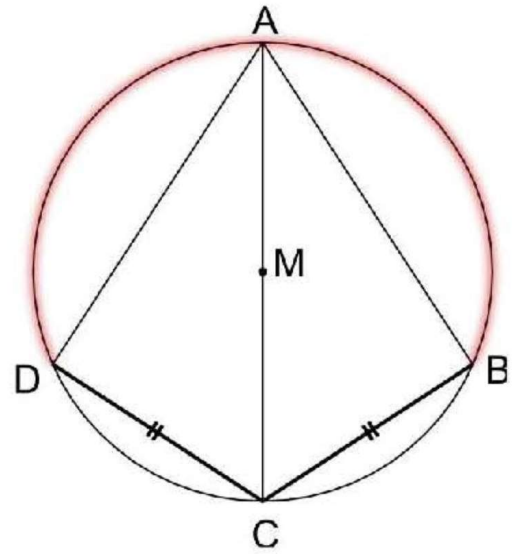

## Solution

$\because \overline{AC}$  diameter

$$\therefore m(\widehat{ABC}) = m(\widehat{ADC}) \implies (1)$$

$\because BC = DC \implies$  chords equal

$$\therefore m(\widehat{BC}) = m(\widehat{CD}) \leftarrow \text{arcs equal} \implies (2)$$

Subtract (2) from (1)

$$\therefore m(\widehat{AB}) = m(\widehat{AD})$$

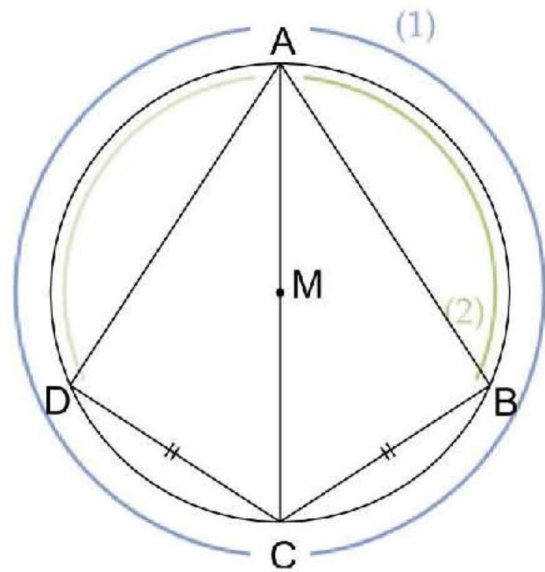

**Q2:**

In the opposite figure:

$\overline{AB}$  is a diameter of the circle  $M$ ,

$$m(\angle CMD) = 70^\circ, m(\widehat{AC}) : m(\widehat{DB}) = 5 : 6$$

**Find:**  $m(\widehat{ACD})$

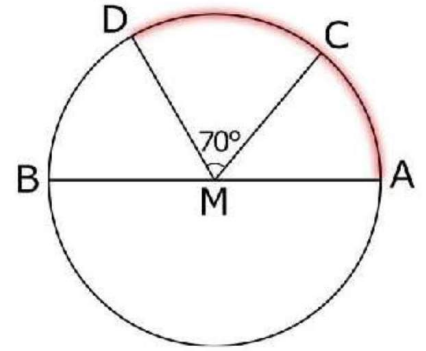

**Solution**

$\therefore \overline{AB}$  diameter

$$\therefore m(\widehat{ACB}) = 180^\circ$$

$$m(\widehat{DC}) = m(\angle CMD) = 70^\circ \leftarrow \text{central angle}$$

$$\therefore m(\widehat{AC}) : m(\widehat{DB}) = 5 : 6$$

$$\therefore 5x + 6x + 70 = 180$$

$$\therefore x = 10$$

$$m(\widehat{AC}) = 5 \times 10 = 50^\circ$$

$$m(\widehat{ACD}) = 50 + 70 = 120^\circ$$

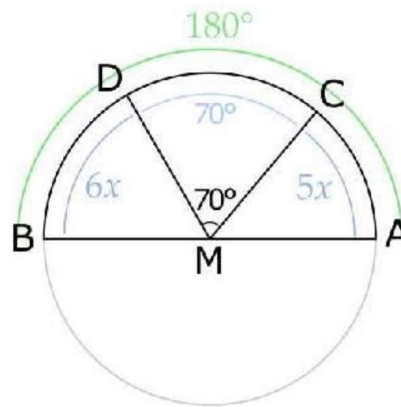

**Q3:**

In the opposite figure:

$M$  is a circle,  $\overleftrightarrow{CD}$  is a tangent to the circle at  $C$ ,

$\overline{AB}$  and  $\overline{EF}$  are two chords in the circle,

where  $\overline{AB} \parallel \overline{EF} \parallel \overleftrightarrow{CD}$

**Prove that:**  $CE = CF$

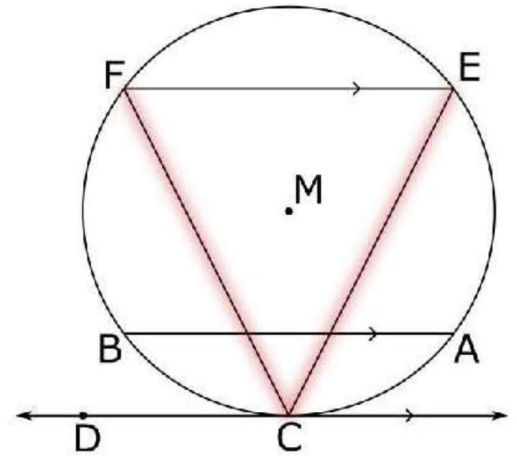

**Solution**

$$\therefore \overline{FE} \parallel \overleftrightarrow{CD}$$

$$\therefore m(\widehat{EC}) = m(\widehat{CF}) \implies \text{arcs equal}$$

$$\therefore CE = CF \Leftarrow \text{chords equal}$$

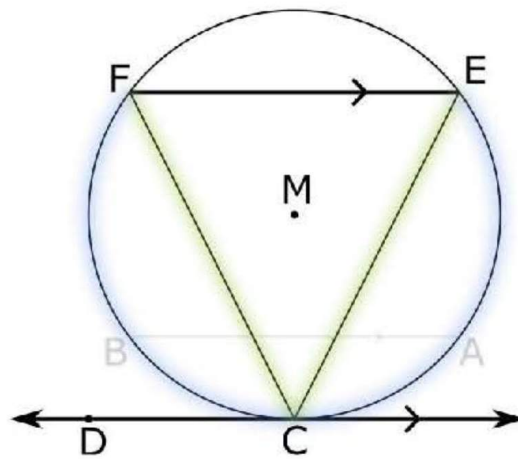

**Q4:**

In the opposite figure:

$ABCD$  is rectangle inscribed in a circle.

Draw the chord  $\overline{CE}$ , where  $CE = CD$

**Prove that:**  $AE = BC$

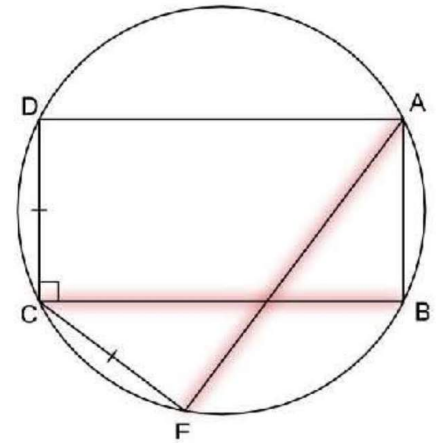

**Solution**

$\therefore AB = CD$  (rectangle)  
 $, CE = CD$  (given)

$\therefore AB = CE \implies$  chords equal

$\therefore m(\widehat{AB}) = m(\widehat{CE}) \Leftarrow$  arcs equal

adding  $m(\widehat{BE})$

$\therefore m(\widehat{AE}) = m(\widehat{BC}) \implies$  arcs equal

$\therefore AE = BC \Leftarrow$  chords equal

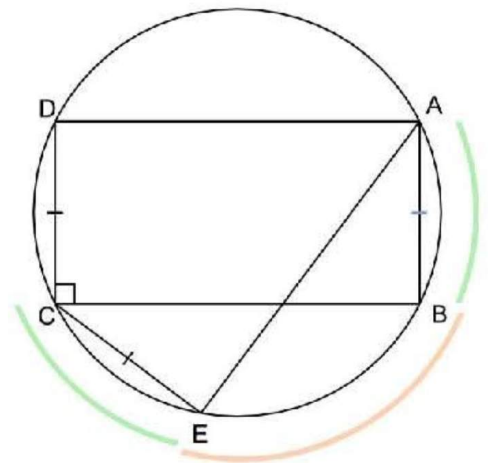

**Q5:**

In the opposite figure:

$M$  is a circle with radius length of  $15\text{ cm}$ ,  $\overline{AB}$  and  $\overline{CD}$  are two parallel chords of the circle,  $m(\widehat{AC}) = 80^\circ$ , length of  $\widehat{AC} = \text{length of } \widehat{AB}$

**Find:**

- $m(\angle MAB)$
- $m(\widehat{CD})$
- The length of  $\widehat{CD}$

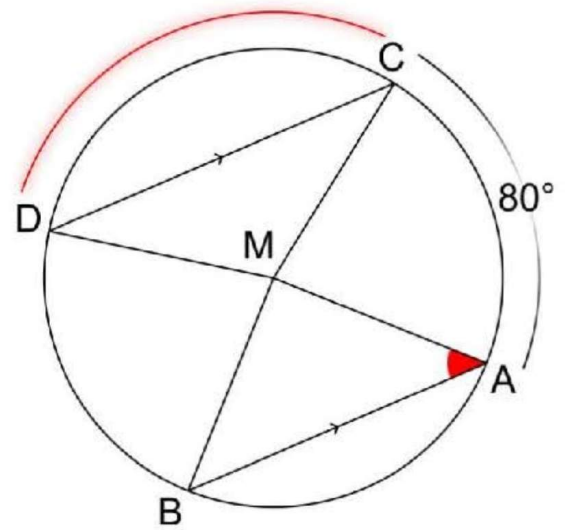

**Solution**

$\therefore \text{length of } \widehat{AC} = \text{length of } \widehat{AB}$   
 $\therefore m(\widehat{AC}) = m(\widehat{AB}) = 80^\circ \leftarrow \text{arcs equal}$   
 $\therefore m(\angle AMB) = 80^\circ \leftarrow \text{Central angle}$

in  $\triangle AMB$ :

$\therefore MA = MB = r$

$\therefore m(\angle MAB) = \frac{180 - 80}{2} = 50^\circ$

$\therefore \overline{AB} \parallel \overline{CD}$

$\therefore m(\widehat{AC}) = m(\widehat{BD}) = 80^\circ \leftarrow \text{arcs equal}$

$\therefore m(\widehat{CD}) = 360 - (80 + 80 + 80) = 120^\circ$

$\text{length of } \widehat{CD} = \frac{120}{360} \times 2 \times 3.14 \times 15 = 31.4\text{cm}$

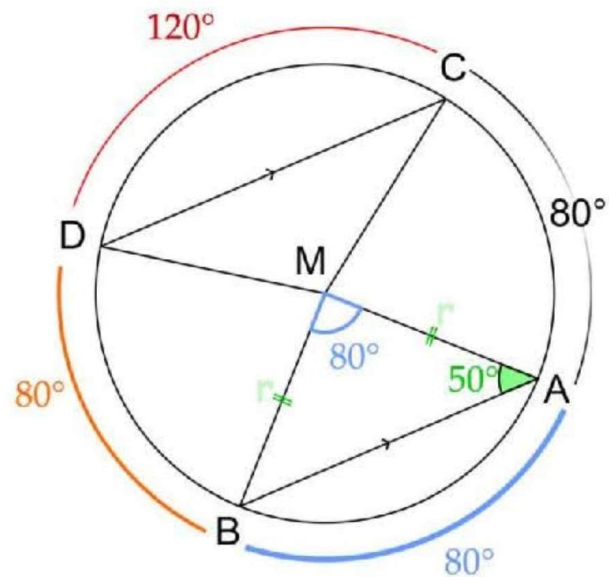

**Q6:**

In the opposite figure:  
 $ABCD$  is a quadrilateral  
 inscribed in the circle in  
 which  $AC = BD$  ,  
 $AB = (3x - 5) \text{ cm}$  ,  
 $CD = (x + 3) \text{ cm}$

**Find:** The length of  $\overline{AB}$

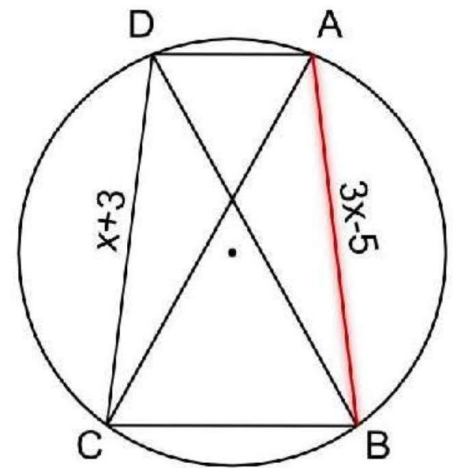

**Solution**

$\therefore AC = BD \implies \text{chords equal}$   
 $\therefore m(\widehat{ABC}) = m(\widehat{BCD}) \Leftarrow \text{arcs equal}$

**Subtract  $m(\widehat{BC})$**

$\therefore m(\widehat{AB}) = m(\widehat{CD}) \implies \text{arcs equal}$   
 $\therefore AB = CD \Leftarrow \text{chords equal}$

$$\begin{aligned} \therefore 3x - 5 &= x + 3 \\ \therefore 2x &= 8 \\ \therefore x &= 4 \end{aligned}$$

$\therefore AB = 7\text{cm}$

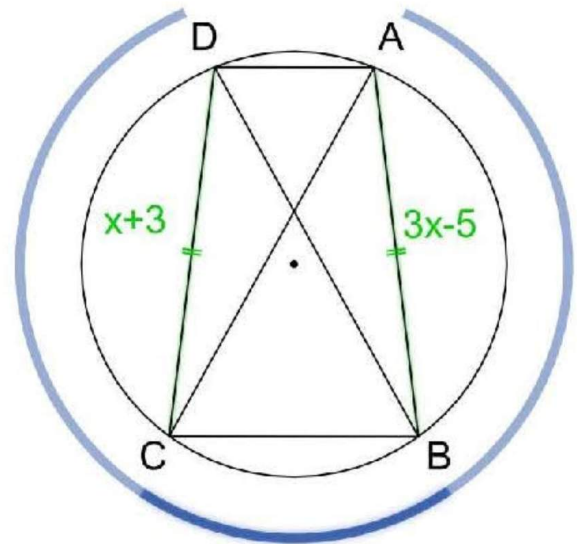

**Q7:**

In the opposite figure:

$\overline{AB}$  is a diameter in the circle  $M$ ,

$\overline{DE}$  is a tangent to it at  $C$ ,  $\overline{AB} \parallel \overline{DE}$ ,

$X$  is midpoint of  $\widehat{AC}$ ,  $m(\widehat{BY}) = 2m(\widehat{CY})$

**Find:** The measures of the angles of  $\triangle MDE$

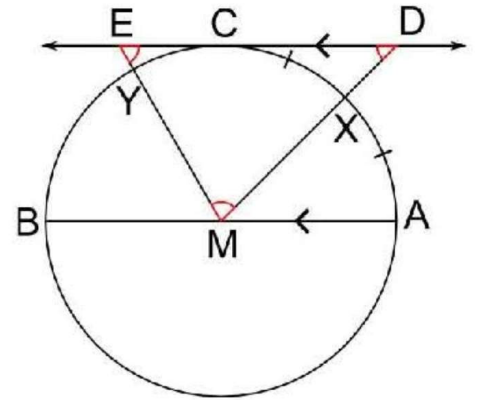

**Solution**

$\because \overline{AB}$  diameter  $\dots\dots\dots 180^\circ$

$\therefore m(\widehat{AB}) = 180^\circ$

$\because \overline{AB} \parallel \overline{DE}$

$\therefore m(\widehat{AC}) = m(\widehat{CB}) = 180 \div 2 = 90^\circ$

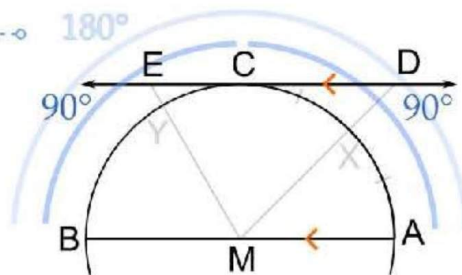

$\because X$  midpoint of  $\widehat{AC}$

$\therefore m(\widehat{AX}) = m(\widehat{XC}) = 90 \div 2 = 45^\circ$

$\therefore m(\angle AMX) = m(\widehat{AX}) = 45^\circ \leftarrow$  central angle

$\therefore m(\angle EDM) = m(\angle AMD) = 45^\circ \leftarrow$  alternate

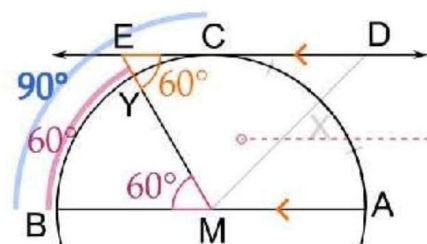
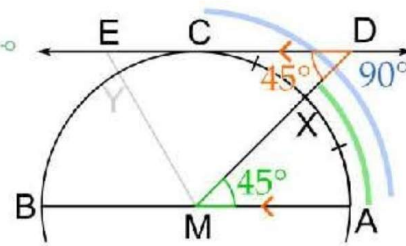

$\therefore m(\widehat{BY}) = 2m(\widehat{CY}) = 60^\circ$

$\therefore m(\angle EMB) = m(\widehat{BY}) = 60^\circ \leftarrow$  central angle

$\therefore m(\angle DEM) = m(\angle EMB) = 60^\circ \leftarrow$  alternate

in  $\triangle MDE$

$\therefore m(\angle DME) = 180 - (45 + 60) = 75^\circ$

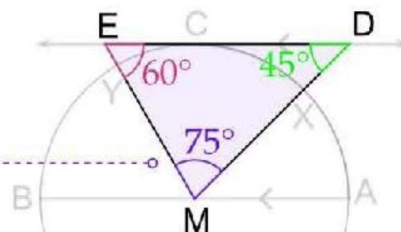

Unit 5 | Lesson 2

" The relation between the inscribed and central angles "

**Q1:**

In the opposite figure:

$\overleftrightarrow{CD}$  is a tangent to the circle at  $C$ ,

$\overleftrightarrow{CD} \parallel \overline{AB}$ ,  $m(\angle AMB) = 120^\circ$

**Prove that:**  $\triangle CAB$  is equilateral.

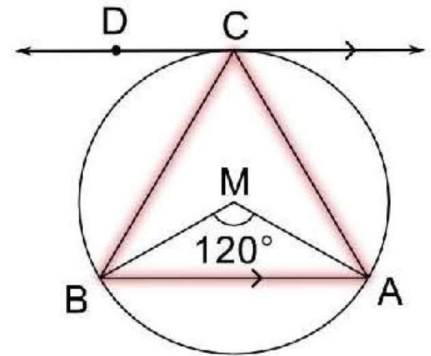

Solution

$$\therefore m(\angle ACB) = \frac{1}{2}m(\angle AMB) \Leftarrow \text{inscribed \& central of } \widehat{AB}$$

$$\therefore m(\angle ACB) = \frac{1}{2} \times 120 = 60^\circ \implies (1)$$

$$\therefore \overleftrightarrow{CD} \parallel \overline{AB}$$

$$\therefore m(\widehat{AC}) = m(\widehat{BC}) \implies \text{arcs equal}$$

$$\therefore AC = AB \Leftarrow \text{chords equal} \implies (2)$$

From (1), (2)

$\therefore \triangle CAB$  is equilateral

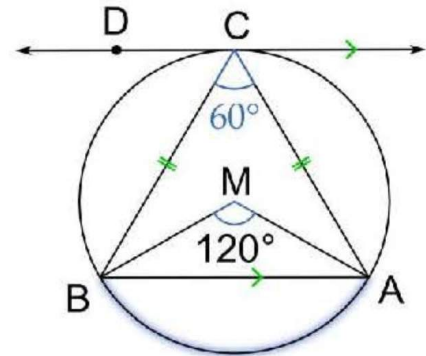

**Q3:**

In the opposite figure:

$\overline{AB}$  is a chord in the circle  $M$ ,

$\overline{CM} \parallel \overline{AB}, \overline{BC} \cap \overline{AM} = \{E\}$

**Prove that:**

$$BE > AE$$

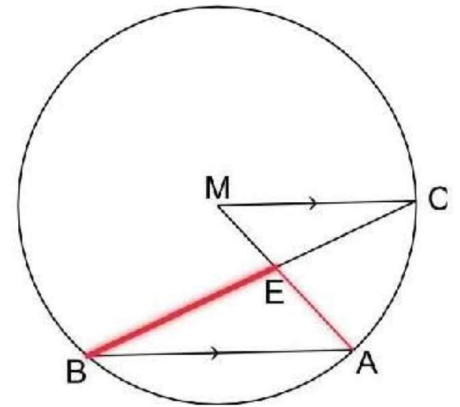

**Solution**

$$m(\angle AMC) = 2m(\angle ABC) \leftarrow \text{inscribed \& central of } \widehat{AC} \implies (1)$$

$$\because \overline{CM} \parallel \overline{AB}$$

$$\therefore m(\angle AMC) = m(\angle A) \leftarrow \text{alternate} \implies (2)$$

From (1), (2)

$$\therefore m(\angle A) = 2m(\angle B)$$

in  $\triangle AEB$

$$\therefore m(\angle A) > m(\angle B)$$

$$\therefore BE > AE$$

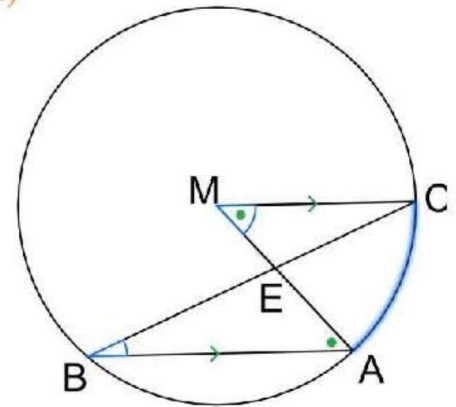

**Q2:**

In the opposite figure:

$\overline{AB}$  is a chord in the circle  $M$ ,

$\overline{MC} \perp \overline{AB}$

**Prove that:**

$$m(\angle AMC) = m(\angle ADB)$$

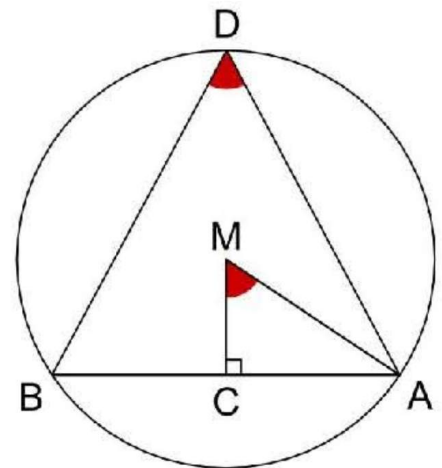

**Solution**

Draw  $\overline{MB}$

$$m(\angle D) = \frac{1}{2}m(\angle AMB) \Leftarrow \text{inscribed \& central of } \widehat{AB} \Rightarrow (1)$$

in  $\triangle AMB$

$$\because AM = BM = r, \overline{MC} \perp \overline{AB}$$

$$\therefore m(\angle AMC) = \frac{1}{2}m(\angle AMB) \Leftarrow \text{bisector} \Rightarrow (2)$$

From (1), (2)

$$\therefore m(\angle AMC) = m(\angle ADB)$$

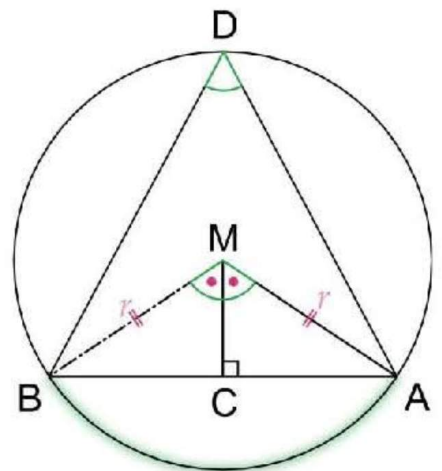

**Q5:**

In the opposite figure:

$$\overline{CB} \cap \overline{ED} = \{A\}, \overline{BE} \cap \overline{CD} = \{F\}, m(\angle A) = 30^\circ,$$

$$m(\widehat{BD}) = 44^\circ, m(\angle DCE) = 48^\circ$$

**Find:**

- $m(\widehat{CE})$
- $m(\widehat{BC})$

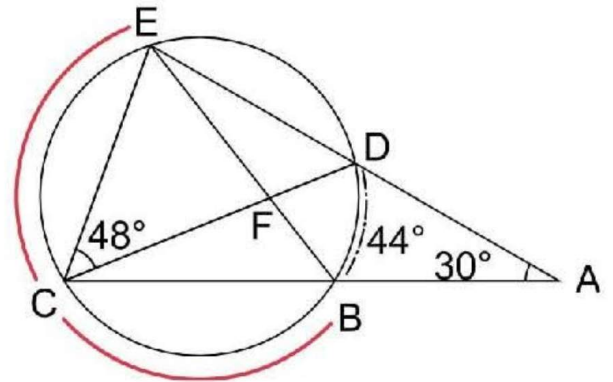

**Solution**

$$\therefore m(\angle A) = \frac{1}{2}[m(\widehat{CE}) - m(\widehat{BD})]$$

$$\therefore \frac{1}{2}[m(\widehat{CE}) - 44] = 30^\circ$$

$$\therefore m(\widehat{CE}) - 44 = 60$$

$$\therefore m(\widehat{CE}) = 104^\circ$$

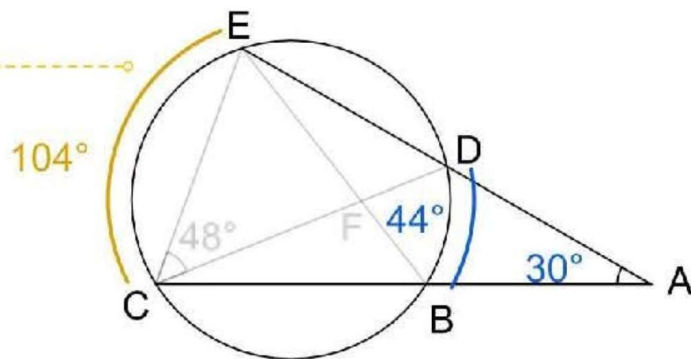

$$\therefore m(\widehat{DE}) = 2m(\angle DCE) \leftarrow \text{inscribed angle}$$

$$= 2 \times 48 = 96^\circ$$

$$\therefore m(\widehat{BC}) = 360 - (44 + 96 + 104) = 116^\circ$$

